



Provides high quality overpressure protection for air, gas, steam, vapor, liquid and two-phase applications in a standardized design.

Features

- Improved, rugged nozzle ring design.
- Improved disc insert retention for ease of maintenance.
- Standard Inconel® 625 bellows and flange material for superior corrosion resistance, longer service life and a wider range of applications.
- Universal disc holder allows for simple and cost-effective conversions from conventional to balanced bellows design.
- Standard threaded bellows design for ease of maintenance and conversion from conventional to balanced bellows design.
- Optional welded bellows attachment is available for special applications.
- Series JLT capacities certified on liquids and gas.
- Improved parts interchangeability, regardless of top construction.
- Field proven series JLT trim (patented) for stable, non-chattering operation on liquid and gas service.
- Standard chrome steel spring for -75°F to +650°F [-28°C to +343°C].
- Easily converted to any type cap or lifting lever construction, liquid trim, soft seat or balanced bellows configurations.
- Full compliance with ASME Boiler and Pressure Vessel Code Section VIII and API Standards 526 and 527.

Valve Series

- JOS-E
- JBS-E
- JBS-BP-E
- JOS-H-E
- JLT-JOS-E
- JLT-JBS-E
- JLT-JBS-BP-E



Contents

Features 1

Introduction/Description 2 - 3

Materials of Construction 4 - 11

Style Designations 12

O-ring Soft Seats 13

Variations from Standard Materials 14 - 15

Caps and Lifting Levers 16

Sizes, Dimensions, and Pressure/Temperature Limits 18 - 47

Capacity Tables (U.S.C.S.) 48 - 54

Equivalents and Conversion Factors 55

Capacity Tables (Metric) 56 - 61

Crosby BlockBody® Pressure Relief Valves 62 - 63

JBS-BP/JLT-JBS-BP Balancing Piston and Large Orifice Relief Valves 64

Ordering Information 65



Total Flow Control Solutions™

Crosby and BlockBody are either trademarks or registered trademarks of Tyco International Services AG or its affiliates in the United States and/or other countries. All other brand names, product names, or trademarks belong to their respective holders.

JOS-E and JBS-E Product Information

Crosby Series JOS-E and JBS-E spring-loaded pressure relief valves have been engineered to provide high quality over-pressure protection for air, gas, steam, vapor, liquid and two-phase applications in an exceptionally rugged, standardized design to the process and power industries.

Series JOS-E and JBS-E pressure relief valves are manufactured in accordance with ASME Pressure Vessel Code, Section VIII and capacities are certified by the National Board of Boiler and Pressure Vessel Inspectors.

All Crosby pressure relief valve castings and forgings are procured to ASME/ASTM material specifications and are available in a number of material combinations such as Monel®, Hastelloy® and stainless steel. In

addition, Series JOS-E and JBS-E relief valves offer a number of special material combinations such as Titanium, Duplex Stainless Steel and Inconel®, and are available on application.

Dimensions of flanges conform to current ANSI Standards. All steel raised face flanges are spiral concentric serrated finish with 45 to 55 grooves per inch and a finish between 125 Ra and 200 Ra. Other flange facings, such as Ring Type Joint, are available on request.

For information pertaining to sizing and selection, refer to the AGC SafetySize computer sizing program.

Bellows and Top Flange

Crosby Series JBS-E and JLT-JBS-E balanced bellows pressure relief valves provide optimum valve performance when the developed back pressure in exhaust systems or discharge manifolds becomes excessive.

All standard JBS-E and JLT-JBS-E relief valves feature a standard bellows and top flange (Figure 1) manufactured from Inconel® alloy 625 which is a fatigue resistant material and provides improved corrosion resistance compared to 316L stainless steel bellows. Inconel® alloy 625 is highly resistant to pitting, crevice corrosion and intergranular attack. The standardization of Inconel® Alloy 625 bellows and top flange provides a higher degree of corrosion resistance without the premium extra charge usually associated with Inconel® bellows.

Ease of Maintenance and Component Interchangeability

The disc insert retention, disc holder and nozzle ring of the JOS-E and JBS-E have been re-engineered to improve maintenance, minimize spare parts and provide more component part interchangeability (Figure 2).

The disc insert is inserted into the disc holder with a retention clip which is compressed as it passes through the smallest diameter in the disc holder recess and then returns to its normal shape once it has passed through. With the retention clip in its original shape, the disc insert is held securely in place.

A “universal” disc holder allows for simple and cost effective conversions from conventional to balanced bellows design as well as cost-effective bellows replacement. The bellows threads on to the disc holder with a tailpiece and gasket.

The new nozzle ring encloses the adjustment slot at the bottom of the ring giving a more rugged, durable design.

Chrome Steel Spring

Standard chrome steel spring material for applications with inlet temperatures up to 650°F [343°C].

Technical Specifications

Sizes: 1” D 2” to 8” T2 10”

Orifices: 0.110 to 27.872 in²
[71 to 17981 mm²]

Inlet Ratings: ANSI Class 150, 300, 600,
900, 1500, 2500

Temperature Range: -450°F to +1000°F
[-268°C to +538°C]

Pressure Range:

JOS-E and JLT-JOS-E:
15 to 6000 psig [1.03 to 413.79 barg]

JBS-E and JLT-JBS-E:
25 to 6000 psig [1.72 to 413.79 barg]

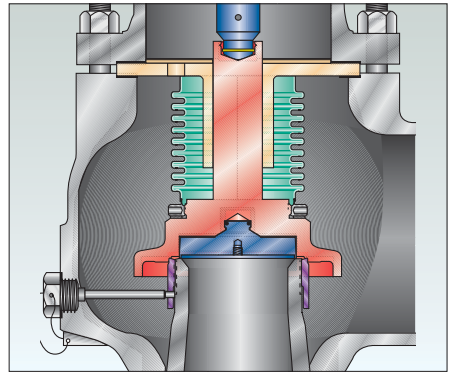

Figure 1

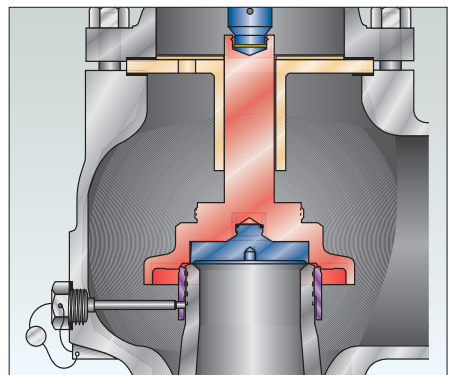

Figure 2

JOS-E and JBS-E Product Information

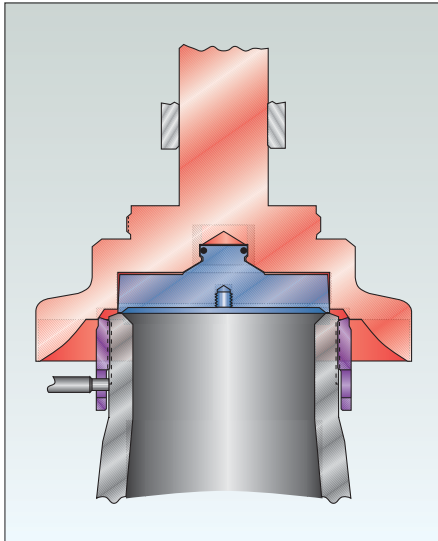

Figure 3

Dual Certification

Crosby patented Series JLT-E (Figure 3) pressure relief valves offer a significant increase in capacity at 10% overpressure resulting in the economic use of a smaller valve as well as a reduction in inlet and discharge piping costs. The JLT-E trim is a field-proven patented design providing stable, non-chattering operation for liquid service.

The JLT-E design is also capacity certified on gas and vapor service and can be applied in two-phase flow applications. The JLT-E design is a logical choice for applications where the process fluid may be a liquid or a gas depending on the overpressure condition.

Bellows Convertibility

The Crosby flanged, spring operated pressure relief valve is designed and manufactured as a conventional valve and a balanced bellows valve. The conversion from conventional Series JOS-E or JLT-JOS-E in sizes 1" D 2" through 8" T2 10" requires only the addition of a bellows assembly and bellows tail-piece gasket. No other parts are necessary since all other parts are completely interchangeable.

Seat Design

Series JOS-E and JBS-E relief valves are available with flat metal-to-metal seats or soft seats. The JOS-E and JBS-E two-piece disc holder/disc insert construction provides thermal balancing assuring maximum seat tightness, and meets the requirements of API Standard 527, Seat Tightness of Pressure Relief Valves.

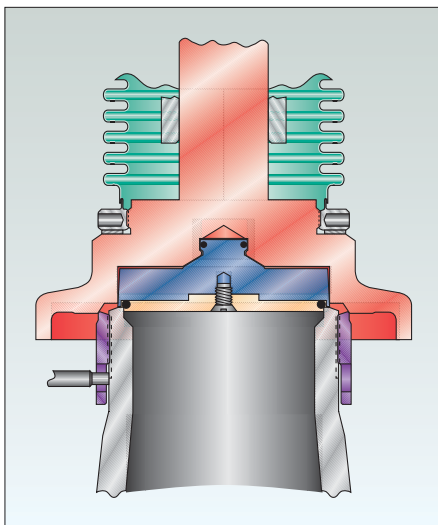

Figure 4

Where system operating conditions permit, soft seat or elastomer seat construction is available as an option. The Crosby O-ring soft seat (Figure 4) is a two-seat design, with a metal-to-metal seat located downstream of the soft seat. The O-ring is the primary seal. The secondary flat metal-to-metal seat controls the compression of the O-ring and also serves as a secondary seal should the O-ring be damaged. Elastomeric O-ring soft seat valves are seat tightness tested at 95% of set pressure, exceeding the requirements of API Standard 527.

Standard O-ring materials include Viton®, BUNA-N, EPR¹, TFE², Silicone Rubber and Kalrez®. Pressure and temperature limits of each material are shown on page 13. Other soft seat materials such as Chemraz® and Aflas® are available on application. Pressure and temperature limits for these soft seat materials are available on application

Cap, Lifting Lever and Spindle Interchangeability

All Crosby JOS-E and JBS-E relief valves use a threaded spindle and drilled and tapped bonnet which permits easy cap or lifting lever conversions, with maximum standardization and interchangeability of parts. In addition, standard cap and lifting lever designs can be used with in-line test devices.

Notes

1. EPR = Ethylene Propylene Rubber.
2. TFE = Tetrafluoroethylene.
3. Viton® and Kalrez® are registered trademarks of DuPont Dow Elastomers.
4. Chemraz® is a registered trademark of Greene, Tweed & Co.
5. Aflas® is a registered trademark of Asahi Glass Company, Ltd.
6. Monel® and Inconel® are registered trademarks of International Nickel Company.
7. Hastelloy® is a registered trademark of Haynes International.

Series JOS-E and JLT-JOS-E Conventional Pressure Relief Valves

Crosby Series JOS-E and JLT-JOS-E are the standard conventional relief valve designs for applications when the discharge is to the atmosphere or when the discharge is to a low pressure exhaust system designed to contain the process fluid. Valves subject to flashing fluids may require a balanced bellows type valve (see page 6).

This exceptionally rugged design features a high guiding surface ratio, corrosion resistant trim, upgraded materials of construction and several other design improvements to ensure ease of maintenance as well as a greater degree of parts interchangeability.

For liquid service applications, Series JLT-JOS-E relief valves provide stable operating performance using the widely industry recognized liquid trim design patented by Crosby. The disc holder in the liquid trim design has been engineered to allow the valve to achieve full lift at 10% overpressure without valve chatter.

Temperature Range

JOS-E and JLT-JOS-E ()5:	-20°F to 650°F [-29°C to 343°C]
JOS-E and JLT-JOS-E ()6:	651°F to 800°F [344°C to 427°C]
JOS-E and JLT-JOS-E ()7:	801°F to 1000°F [428°C to 538°C]

Series JOS-E and JLT-JOS-E Standard Materials of Construction

Ref. No.	Part Name	Standard Material
1	Body – JOS-E and JLT-JOS-E ()5 and ()6	ASME SA216 Gr. WCB
1	Body – JOS-E and JLT-JOS-E ()7	ASME SA217 Gr. WC6
2	Nozzle	316 SS
3	Nozzle Ring	316 SS
4	Set Screw	316 SS
5	Disc Holder	316L SS
8	Disc Insert ¹	316 SS
9	Retention Clip ²	Inconel® X750
10	O-ring ¹	Specify
11	O-ring Retainer	316 SS
12	Retainer Screw(s)	18-8 SS
15	Guide	ASTM A297 Gr. HE SST
16	Spindle	416 SS
17	Spindle Cotter Pin	SS
18	Spring – JOS-E and JLT-JOS-E ()5	Chrome Steel ³
18	Spring – JOS-E and JLT-JOS-E ()6 and ()7	Alloy Steel ^{3,4}
19	Spring Washers	CS
20	Bonnet – JOS-E and JLT-JOS-E ()5 and ()6	ASME SA216 Gr. WCB
20	Bonnet – JOS-E and JLT-JOS-E ()7	ASME SA217 Gr. WC6
21	Bonnet Stud	ASME SA193 Gr. B7
22	Bonnet Stud Nut	ASME SA194 CL 2H
24	Adjusting Bolt	316 SS ⁵
25	Adjusting Bolt Nut	316 SS
26	Pipe Plug (Bonnet)	CS
27	Set Screw Gasket ¹	Organic Fiber Non-Asbestos
28	Guide Gasket ¹	Organic Fiber Non-Asbestos
34	Seal and Wire	Lead and SS
35	Seal Clip (Not Shown)	SS
36	Nameplate (Not Shown)	SS
40	Threaded Cap	CS
41	Cap Gasket ¹	Organic Fiber Non-Asbestos

Notes

1. Recommended Spare Part.
2. Furnished with Disc Insert.
3. Corrosion resistant coating.
4. Crosby may upgrade to Inconel® X750.
5. Class 900#, 1500# and 2500# inlet ratings use 416 SS.

Series JOS-E and JLT-JOS-E Conventional Pressure Relief Valves

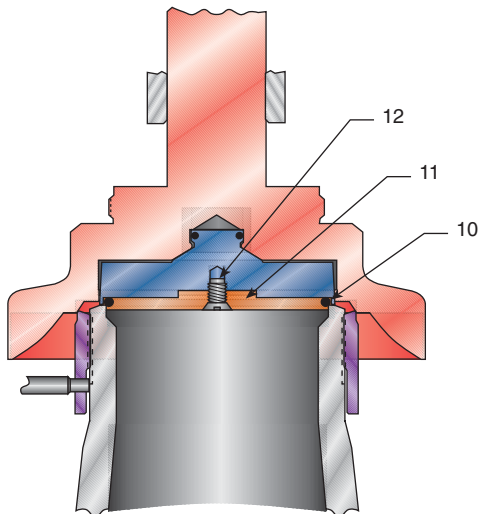

**Series JLT-JOS-E
(with O-ring seat)**

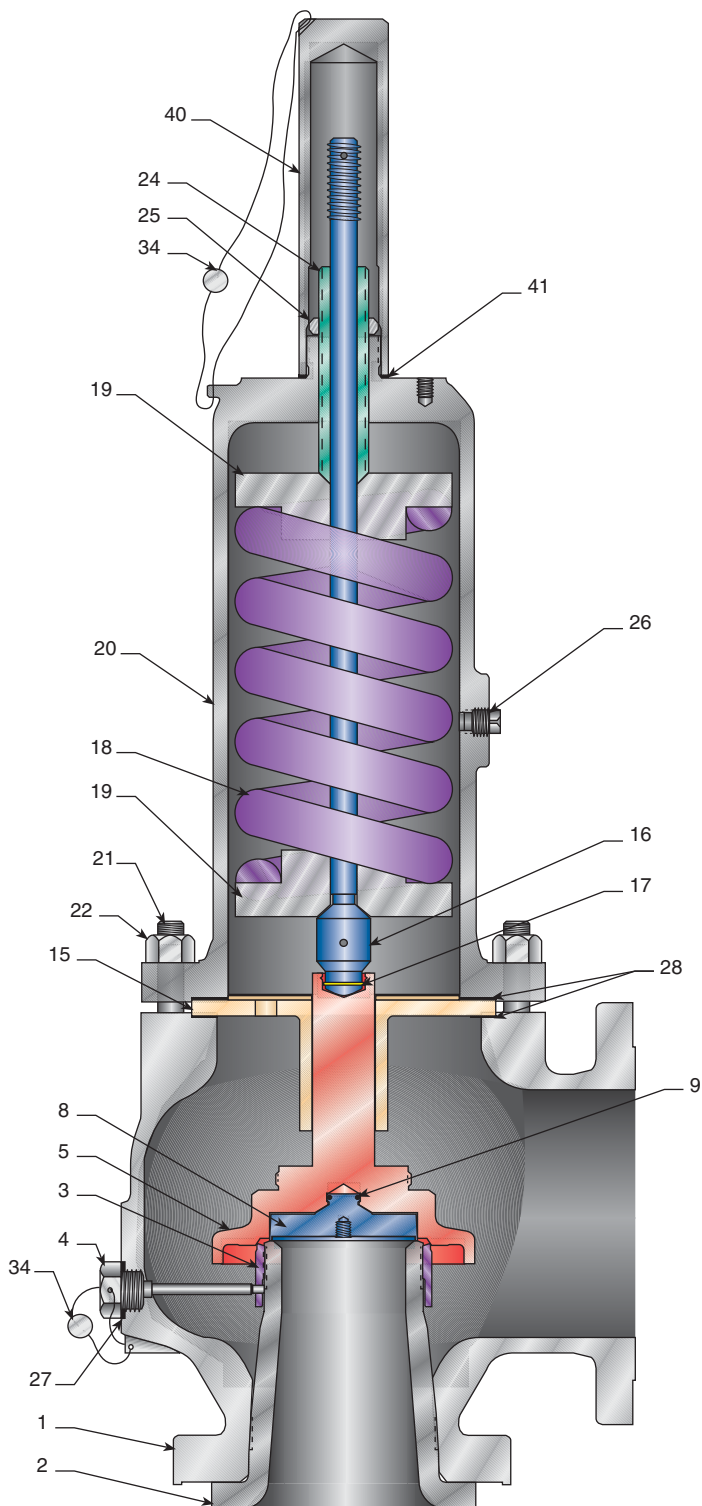

**Series JOS-E
(with metal-to-metal seat)**

Series JBS-E and JLT-JBS-E Balanced Bellows Pressure Relief Valves

Crosby Series JBS-E and JLT-JBS-E are pressure relief valves incorporating a bellows which is balanced to minimize the effect of back pressure on the performance characteristics. The balanced bellows design offsets the effects of variable back pressure on valve set pressure. The balanced bellows valve can also handle applications involving high built-up back pressure.

Additionally, the bellows serves to isolate the guide, spindle, spring and other parts contained in the bonnet chamber from corrosive fluids or media such as a highly viscous fluid or slurry which could render the relief valve inoperative.

For liquid service applications, Crosby offers Series JLT-JBS-E relief valves.

The standard bellows assembly of the Crosby Series JBS-E and JLT-JBS-E threads onto the disc holder with a bellows tailpiece and gasket. A welded bellows attachment is available as an option.

The JBS-E and JLT-JBS-E bellows and bellows flange are supplied in Inconel® 625 as standard material for improved durability, corrosion resistance and service life.

Temperature Range

JBS-E and JLT-JBS-E ()5:	-20°F to 650°F [-29°C to 343°C]
JBS-E and JLT-JBS-E ()6:	651°F to 800°F [344°C to 427°C]
JBS-E and JLT-JBS-E ()7:	801°F to 1000°F [428°C to 538°C]

Series JBS-E and JLT-JBS-E Materials of Construction

No.	Part Name	Standard Material
1	Body – JBS-E and JLT-JBS-E ()5 and ()6	ASME SA216 Gr. WCB
1	Body – JBS-E and JLT-JBS-E ()7	ASME SA217 Gr. WC6
2	Nozzle	316 SS
3	Nozzle Ring	316 SS
4	Set Screw	316 SS
5	Disc Holder	316L SS
6A	Bellows Tailpiece ¹	316L SS
6B	Bellows ¹	Inconel® 625
6C	Bellows Flange ¹	Inconel® 625
8	Disc Insert ²	316 SS
9	Retention Clip ³	Inconel® X750
10	O-ring ²	Specify
11	O-ring Retainer	316 SS
12	Retainer Screw(s)	18-8 SS
15	Guide	ASTM A297 Gr. HE SST
16	Spindle	416 SS
17	Spindle Cotter Pin	SS
18	Spring – JBS-E and JLT-JBS-E ()5	Chrome Steel ⁴
18	Spring – JBS-E and JLT-JBS-E ()6 and ()7	Alloy Steel ^{4,5}
19	Spring Washers	CS
20	Bonnet – JBS-E and JLT-JBS-E ()5 and ()6	ASME SA216 Gr. WCB
20	Bonnet – JBS-E and JLT-JBS-E ()7	ASME SA217 Gr. WC6
21	Bonnet Stud	ASME SA193 Gr. B7
22	Bonnet Stud Nut	ASME SA194 CL 2H
24	Adjusting Bolt	316 SS ⁶
25	Adjusting Bolt Nut	316 SS
26	Nameplate (not shown)	SS
27	Set Screw Gasket ¹	Organic Fiber Non-Asbestos
28	Guide Gasket ²	Organic Fiber Non-Asbestos
29	Tailpiece Gasket ²	Organic Fiber Non-Asbestos
34	Seal and Wire	Lead and SS
35	Seal Clip (not shown)	SS
40	Threaded Cap	CS
41	Cap Gasket ²	Organic Fiber Non-Asbestos

Notes

1. Subassembly.
2. Recommended Spare Part.
3. Furnished with Disc Insert.
4. Corrosion resistant coating.
5. Crosby may upgrade to Inconel® X750.
6. Class 900#, 1500# and 2500# inlet ratings use 416 SS.

Series JBS-E and JLT-JBS-E Balanced Bellows Pressure Relief Valves

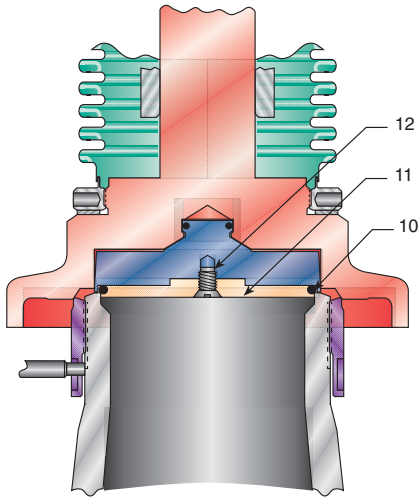

Series JBS-E
(with O-ring seat)

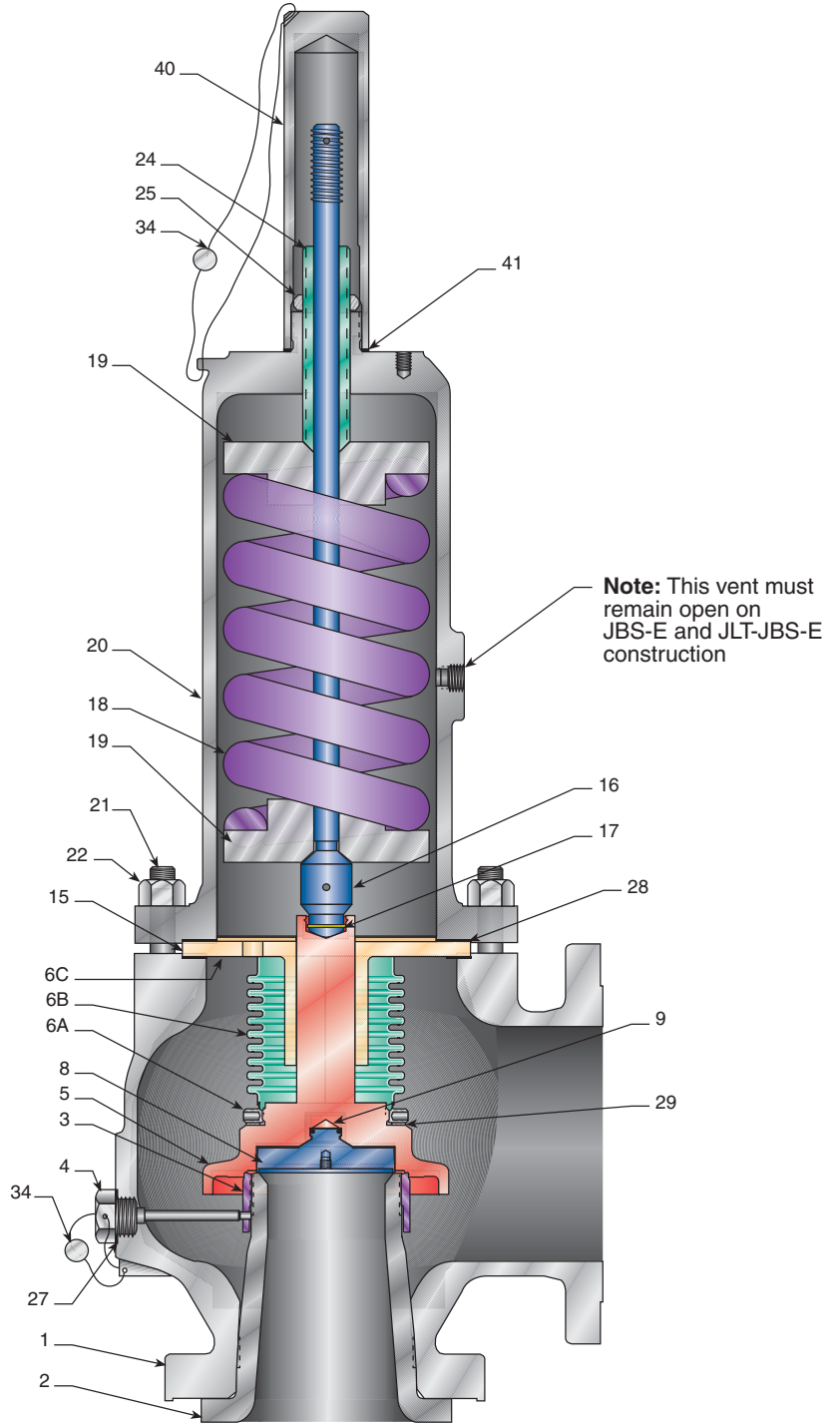

Series JBS-E
(with metal-to-metal seat)

Series JLT-JOS-E and JLT-JBS-E Liquid Trim Pressure Relief Valves

Crosby Series JLT-E pressure relief valves for liquid service were developed using Crosby's unique patented trim design (Figure 1) with over twenty years of successful field experience was patented prior to the issuance of ASME Code Section VIII requirements that became mandatory in 1985. The JLT-E trim offers a significant increase in capacity at 10% overpressure and in many cases, results in selection of a smaller valve with an associated reduction in inlet and discharge piping costs.

The liquid trim design provides smooth and stable valve operation on liquid service applications. When system pressure reaches the specified set pressure, a small steady stream of fluid begins to flow from the valve. Valve disc lift at this pressure is minimal.

As the system pressure increases into the range of 3% to 5% overpressure, the valve then opens with a pop type lift to the full lift position. At 10% overpressure, the JLT-E valve will have attained full lift and be flowing an amount equal to or greater than the rated capacity (Figure 2).

As the system pressure begins to decay, flow through the valve decreases until the valve reseats with a clean positive closing action.

The JLT-E design is also capacity certified for gas and vapor service and can be applied in two-phase flow applications. The JLT-E design is a logical choice where the process fluid may be a liquid or gas depending on the overpressure condition.

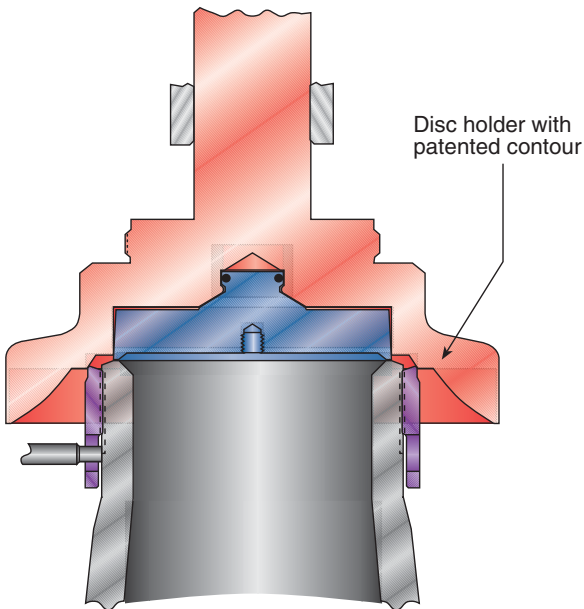

Figure 1

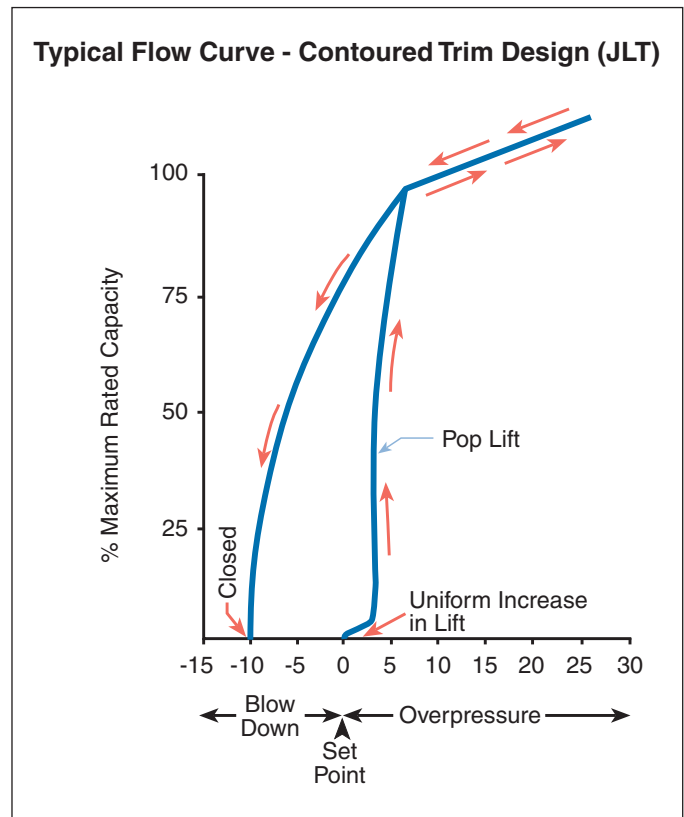

Figure 2

Series JOS-H-E Conventional Open Bonnet Pressure Relief Valves

Series JOS-H-E relief valves (Figure 1) are primarily for ASME Code Section VIII steam service applications and are furnished with a regular lifting lever as standard.

Optional accessories include test rod as well as weatherhood. Materials of construction are identical to the standard closed bonnet JOS-E design (see page 4). The JOS-H-E has a

maximum temperature rating of 800°F [427°C] using WCB carbon steel body and bonnet and chrome steel spring.

Series JOS-H-E (and JOS-E) relief valves for steam service at set pressures above 450 psig, use 316L stainless steel disc holder with disc bushing and 17-4 ph stainless steel disc insert (see Figure 2).

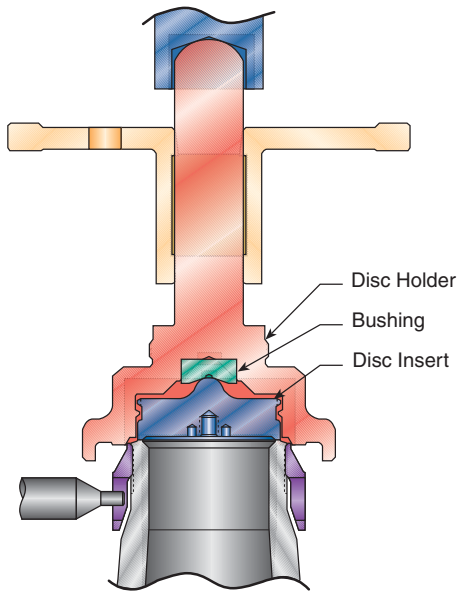

Steam Service Trim for set pressures greater than 450 psi

Figure 2

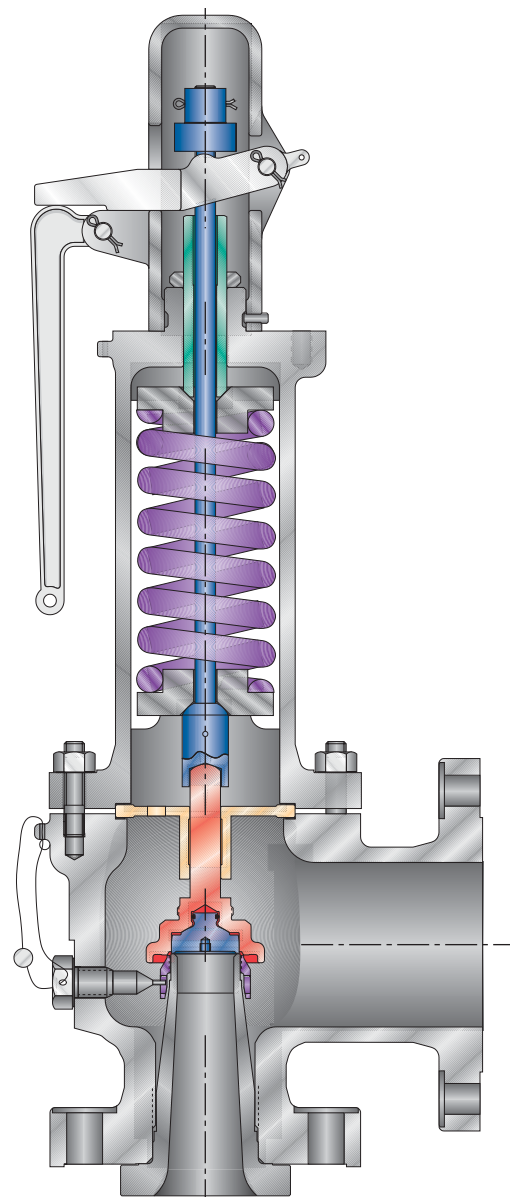

JOS-H-E Conventional Open Bonnet

Figure 1

Series JOS-E and JLT-JOS-E

Conventional Pressure Relief Valves for Sour Gas Service per NACE MR0175 (2002 Edition)¹

Level 1 - For applications where compliance with NACE MR0175 is required for wetted parts in the primary (upstream) pressure zone of the pressure relief valve. Materials of construction for Level 1 are standard and can be found on page 4.

Level 2 - For applications where compliance with NACE MR0175 is required for wetted parts in the primary (upstream) and secondary (downstream) pressure zones of the pressure relief valve.

While the materials recommended for the Series JOS-E and JLT-JOS-E sour gas valves are suitable for average service conditions, optional materials are available to provide additional resistance to corrosion beyond the minimum requirements of the standard.

Series JOS-E and JLT-JOS-E Materials of Construction

Ref No.	Part Name	Standard NACE Material Level 2
1	Body	ASME SA216 Gr. WCB
2	Nozzle	316 SS
3	Nozzle Ring	316 SS
4	Set Screw	316 SS
5	Disc Holder	316L SS
8	Disc Insert	316 SS
9	Retention Clip	Inconel® X750
15	Guide	ASTM A297 Gr. HE SST
16	Spindle	316 SS*
17	Spindle Cotter Pin	SS
18	Spring	Inconel® X750*
19	Spring Washer	316 SS*
20	Bonnet	ASME SA216 Gr. WCB
21	Bonnet Stud	Alloy Steel ²
22	Bonnet Stud Nut	Alloy Steel ²
24	Adjusting Bolt	316 SS*
25	Adjusting Bolt Nut	316 SS
26	Pipe Plug (Bonnet)	CS
27	Set Screw Gasket	Organic Fiber Non-Asbestos
28	Guide Gasket	Organic Fiber Non-Asbestos
34	Seal and Wire	Lead and SS
35	Seal Clip (not shown)	SS
40	Threaded Cap	CS
41	Cap Gasket	Organic Fiber Non-Asbestos

* Variation from standard and NACE Level 1 product.

Notes

1. Contact factory for compliance to NACE MR0175 (2003 Edition) or NACE MR0175/ISO 15156 requirements.
2. If the valve bolting could be directly exposed or in contact with the hydrogen sulfide environment, bonnet studs can be ASME A193 Gr. B7M HRC-22 maximum and bonnet stud nuts can be ASME A194 Class 2HM HRC-22 maximum.

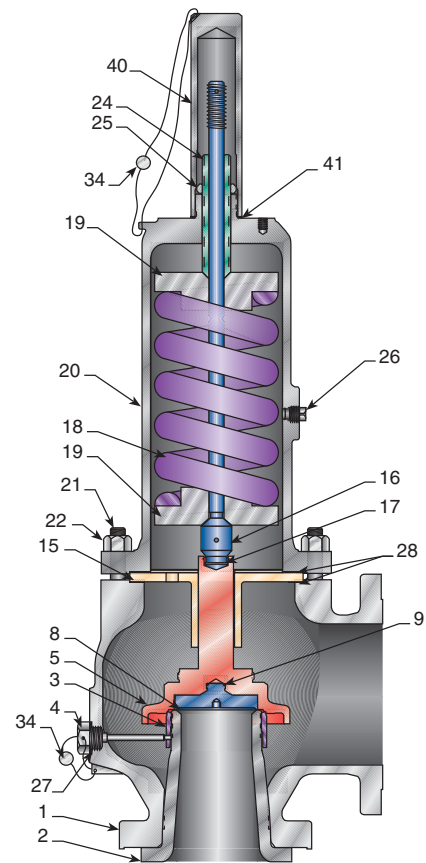

Series JOS-E

Series JBS-E and JLT-JBS-E

Balanced Bellows Pressure Relief Valves for Sour Gas Service per NACE MR0175 (2002 Edition)¹

Level 1 - For applications where compliance with NACE MR0175 is required for wetted parts in the primary (upstream) pressure zone of the pressure relief valve. Materials of construction for Level 1 are standard and can be found on page 6.

Level 2 - For applications where compliance with NACE MR0175 is required for wetted parts in the primary (upstream) and secondary (downstream) pressure zones of the pressure relief valve. The Inconel® 625 bellows isolates the valve spring and other critical components above it from the process fluid.

While the materials recommended for the Series JBS-E and JLT-JBS-E sour gas valves are suitable for average service conditions, optional materials are available to provide additional resistance to corrosion beyond the minimum requirements of the standard.

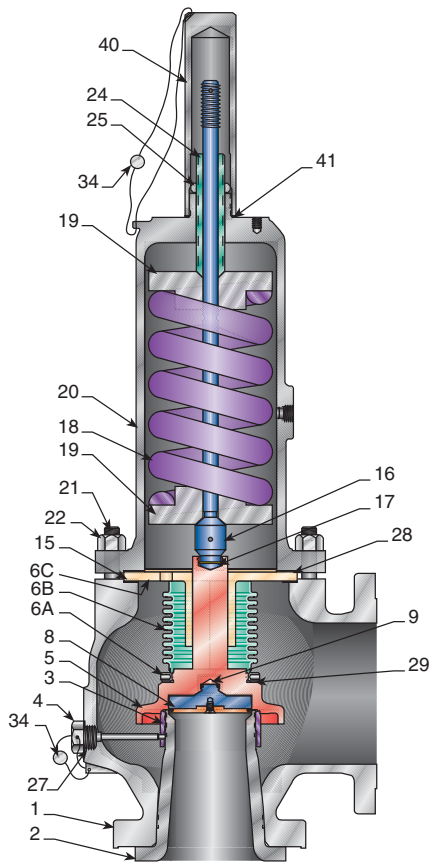

**Series JBS-E
(with bellows)**

Series JBS-E and JLT-JBS-E Materials of Construction

Ref No.	Part Name	Standard NACE Material Level 2
1	Body	ASME SA216 Gr. WCB
2	Nozzle	316 SS
3	Nozzle Ring	316 SS
4	Set Screw	316 SS
6C	Bellows Flange ²	Inconel® 625
6B	Bellows ²	Inconel® 625
6A	Bellows Tailpiece ²	316L SS
5	Disc Holder	316L SS
8	Disc Insert	316 SS
9	Retention Clip	Inconel® X750
15	Guide	ASTM A297 Gr. HE SST
16	Spindle	416 SS
17	Spindle Cotter Pin	SS
18	Spring	Chrome Steel-Aluminum Metallized*
19	Spring Washer	Steel
20	Bonnet	ASME SA216 Gr. WCB
21	Bonnet Stud	Alloy Steel ³
22	Bonnet Stud Nut	Steel ³
24	Adjusting Bolt	316 SS
25	Adjusting Bolt Nut	316 SS
27	Set Screw Gasket	Organic Fiber Non-Asbestos
28	Guide Gasket	Organic Fiber Non-Asbestos
29	Tailpiece Gasket	Organic Fiber Non-Asbestos
34	Seal and Wire	Lead and SS
35	Seal Clip (not shown)	SS
40	Threaded Cap	CS
41	Cap Gasket	Organic Fiber Non-Asbestos

* Variation from standard product.

Notes

- Contact factory for compliance to NACE MR0175 (2003 Edition) or NACE MR0175/ISO 15156 requirements.
- Subassembly.
- If the valve bolting could be directly exposed or in contact with the hydrogen sulfide environment, bonnet studs can be ASME A193 Gr. B7M HRC-22 maximum and bonnet stud nuts can be ASME A194 Class 2HM HRC-22 maximum.

Series Designations

Size Inlet x Orifice x Outlet	Series	Seat Type	Pressure/Temperature Inlet Flange Range Ratings ³		Material Variations ⁴	Caps and Lifting Levers (Type)
1" D 2" thru 8" T2 10"	JOS-E- Conventional JBS-E-with bellows JLT-JOS-E- Conventional with liquid trim ¹ JLT-JBS-E-Bellows with liquid trim ¹ JBS-BP-E-Bellows with back pressure balancing piston JLT-JBS-BP-E- Bellows with liquid trim and back pressure balancing piston ¹ JOS-H-E - Conventional JOS with open bonnet for ASME Code Section VIII steam service to +800°F [+427°C] ²	None - Metal "OR" - O-ring When ordering soft seats, specify material.	1 - CL 150 Flange 2 - CL 300 Flange 3 - CL 300 Flange 4* - CL 600 Flange 5 - CL 900 Flange 6 - CL 1500 Flange 7 - CL 2500 Flange *Except "T" and "T2" orifice is CL 300 flange	2 - -450°F to -76°F [-268°C to -60°C] 4 - -75°F to -21°F [-59°C to -30°C] 5* - -20°F to +650°F [-29°C to +343°C] 6 - +651°F to +800°F [+344°C to +427°C] 7 - +801°F to +1000°F [+428°C to +538°C] *Except for Series JOS-H-E with open bonnet, chrome steel spring may be used to +800°F [+427°C]	None - Standard Materials S - All 316 SS. S4 - All 316 SS except body, bonnet, cap and spring M - All Monel® with Monel® or Inconel® spring M1 - Monel® nozzle and disc insert M4 - All Monel® except body, bonnet, cap, spring and washers M5 - All Monel® except spring and washers H - All Hastelloy® C H1 - Hastelloy® C nozzle and disc insert H4 - All Hastelloy® C except body, bonnet, cap, spring and washers H5 - All Hastelloy® C except spring and washers N2 - NACE Level 2 JOS-E = Inconel® X750 spring, 316 SS washers, spindle and adjusting bolt JBS-E = Aluminum Metallized Spring	Type J - (Standard) threaded cap Type K - Threaded cap with test rod Type C - Regular lifting lever ⁵ Type D - Packed lifting lever ⁵ Type E - Packed lifting lever with test rod ⁵ Type L - Bolted cap Type M - Bolted cap with test rod Optional Caps for Height Restricted Applications Type A - Threaded cap Type B - Threaded cap with test rod Type G - Bolted cap Type H - Bolted cap with test rod

Available Options

- Welded bellows attachment
- Flange facings such as ring type joint
- Special connections such as tri-clamp, Grayloc, etc.
- Special CL 300 outlets (where not standard)
- Special Teflon® (FEP) bellows coating
- Special spring coatings or plating
- Materials of construction for applications above 1000°F
- Bonnet and cap inside painting or plastic coating
- Special materials not cataloged
- Flanges to international standards
- Position indicators, proximity switches, etc.
- Stellite nozzle and disc insert
- Special casting or machined surface tests
- Special cleaning
- Special painting or coatings
- Special testing
- Steam jacketed bodies
- Lethal service construction

Notes

1. Series designations "JLT-JOS-E", "JLT-JBS-E", or "JLT-JBS-BP-E" signify Series JOS-E, JBS-E or JBS-BP-E with liquid trim for liquid and/or gas service.
2. Upper temperature limit is +800°F [+427°C] for Series JOS-H-E open bonnet valve for ASME Code Section VIII steam service.
3. See pages 18 - 47 for appropriate maximum set pressures and temperatures.
4. See pages 4 - 11 for complete listings of materials of construction.
5. ASME Code Section VIII rules require that pressure relief valves for water service over +140°F [+60°C], steam and air shall have a lifting device.

JOS-E, JBS-E and JLT-E – Variations from Standard Materials

Ref. No.	Part Name	Low Temperature		316 Stainless Steel	
		JOS-E/JBS-E/JLT-E()4 -75°F to -21°F [-59°C to -30°C]	JOS-E/JBS-E/JLT-E()2 -450°F to -76°F [-268°C to -60°C]	() () S4	() () S
1	Body	ASME SA351 Gr. CF8M	ASME SA351 Gr. CF8M	ASME SA216 Gr. WCB	ASME SA351 Gr. CF8M
2	Nozzle	316 SS	316 SS	316 SS	316 SS
3	Nozzle Ring	316 SS	316 SS	316 SS	316 SS
4	Set Screw	316 SS	316 SS	316 SS	316 SS
5	Disc Holder	316L SS	316L SS	316L SS	316L SS
6C	Bellows Flange(1)	Inconel 625	Inconel 625	Inconel 625	Inconel 625
6B	Bellows(1)	Inconel 625	Inconel 625	Inconel 625	Inconel 625
6A	Bellows Tailpiece(1)	316L SS	316L SS	316L SS	316L SS
8	Disc Insert(2)	316 SS	316 SS	316 SS	316 SS
9	Retention Clip(3)	Inconel X750	Inconel X750	Inconel X750	Inconel X750
10	O-ring	Specify	Specify	Specify	Specify
11	O-ring Retainer	316 SS	316 SS	316 SS	316 SS
12	Retainer Screws	18-8 SS	18-8 SS	18-8 SS	18-8 SS
15	Guide	ASTM A297 Gr. HE SST	ASTM A297 Gr. HE SST	ASTM A297 Gr. HE SST	ASTM A297 Gr. HE SST
16	Spindle	416 SS	316 SS	316 SS	316 SS
17	Spindle Cotter Pin	SS	SS	SS	SS
18	Spring	Chrome Steel(4)	316 SS	Chrome Steel(4) or Alloy Steel(5)	316 SS(7) or Inconel X750
19	Spring Washers	CS	316 SS	316 SS	316 SS
20	Bonnet	ASME SA351 Gr. CF8M	ASME SA351 Gr. CF8M	ASME SA216 Gr. WCB	ASME SA351 Gr. CF8M
21	Bonnet Stud	304 SS	304 SS	ASME SA193 Gr. B7	304 SS
22	Bonnet Stud Nut	304 SS	304 SS	ASME SA194 CL 2H	304 SS
24	Adjusting Bolt	316 SS(6)	316 SS	316 SS	316 SS
25	Adjusting Bolt Nut	316 SS	316 SS	316 SS	316 SS
26	Nameplate (not shown)	SS	SS	SS	SS
27	Set Screw Gasket(1)	Organic Fiber Non-Asbestos	Organic Fiber Non-Asbestos	Organic Fiber Non-Asbestos	Organic Fiber Non-Asbestos
28	Guide Gasket(2)	Organic Fiber Non-Asbestos	Organic Fiber Non-Asbestos	Organic Fiber Non-Asbestos	Organic Fiber Non-Asbestos
29	Tailpiece Gasket(2)	Organic Fiber Non-Asbestos	Organic Fiber Non-Asbestos	Organic Fiber Non-Asbestos	Organic Fiber Non-Asbestos
34	Seal and Wire	Lead & SS	Lead & SS	Lead & SS	Lead & SS
35	Seal Clip (not shown)	SS	SS	SS	SS
40	Threaded Cap	316 SS	316 SS	CS	316 SS
41	Cap Gasket(2)	Organic Fiber Non-Asbestos	Organic Fiber Non-Asbestos	Organic Fiber Non-Asbestos	Organic Fiber Non-Asbestos

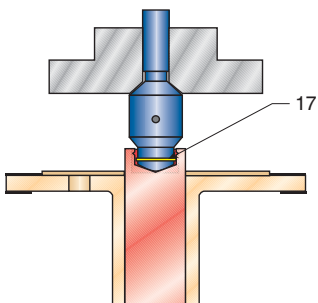

Cotter Pins
Used in L orifice and above only

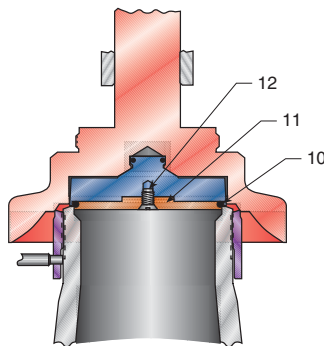

JLT
O-ring Soft Seat

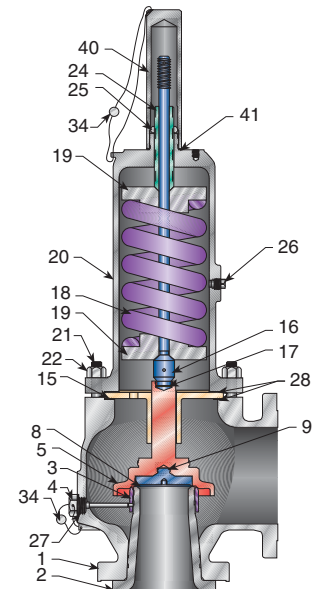

JOS-E

JOS-E, JBS-E and JLT-E – Variations from Standard Materials (continued)

Ref. No.	Part Name	Monel®				Hastelloy®			
		() () M1	() () M4	() () M5	() () M	() () H1	() () H4	() () H5	() () H
1	Body	ASME SA216 Gr. WCB	ASME SA216 Gr. WCB	ASME SA494 Gr. M35-1(9)	ASME SA494 Gr. M35-1(9)	ASME SA216 Gr. WCB	ASME SA216 Gr. WCB	ASME SA494 Gr. CW-12MW	ASME SA494 Gr. CW-12MW
2	Nozzle	Monel	Monel	Monel	Monel	Hastelloy C	Hastelloy C	Hastelloy C	Hastelloy C
3	Nozzle Ring	316 SS	Monel	Monel	Monel	316 SS	Hastelloy C	Hastelloy C	Hastelloy C
4	Set Screw	316 SS	Monel	Monel	Monel	316 SS	Monel	Hastelloy C	Hastelloy C
5	Disc Holder	316L SS	Monel	Monel	Monel	316L SS	Hastelloy C	Hastelloy C	Hastelloy C
6C	Bellows Flange(1)	Inconel 625	Monel	Monel	Monel	Inconel 625	Hastelloy C	Hastelloy C	Hastelloy C
6B	Bellows(1)	Inconel 625	Monel	Monel	Monel	Inconel 625	Hastelloy C	Hastelloy C	Hastelloy C
6A	Bellows Tailpiece(1)	316L SS	Monel	Monel	Monel	316L SS	Hastelloy C	Hastelloy C	Hastelloy C
8	Disc Insert(2)	Monel	Monel	Monel	Monel	Hastelloy C	Hastelloy C	Hastelloy C	Hastelloy C
9	Retention Clip(3)	Inconel X750	Inconel X750	Inconel X750	Inconel X750	Inconel X750	Inconel X750	Inconel X750	Inconel X750
10	O-ring	Specify	Specify	Specify	Specify	Specify	Specify	Specify	Specify
11	O-ring Retainer	Monel	Monel	Monel	Monel	Hastelloy C	Hastelloy C	Hastelloy C	Hastelloy C
12	Retainer Screws	Monel	Monel	Monel	Monel	Hastelloy C	Hastelloy C	Hastelloy C	Hastelloy C
15	Guide	ASTM A297 Gr. HE SST	Monel	Monel	Monel	ASTM A297 Gr. HE SST	Hastelloy C	Hastelloy C	Hastelloy C
16	Spindle	416 SS	Monel	Monel	Monel	416 SS	Monel	Hastelloy C	Hastelloy C
17	Spindle Cotter Pin	SS	Monel	Monel	Monel	SS	Monel	Hastelloy or Monel	Hastelloy or Monel
18	Spring	Chrome Steel(4) or Alloy Steel(5)	Chrome Steel Nickle Plated(8)	Chrome Steel Nickle Plated(8)	Monel or Inconel X750	Chrome Steel(4) or Alloy Steel(5)	Chrome Steel Nickle Plated(8)	Chrome Steel Nickle Plated(8)	Hastelloy C
19	Spring Washers	CS	316 SS	316 SS	Monel	CS	316 SS	316 SS	Hastelloy C
20	Bonnet	ASME SA216 Gr. WCB	ASME SA216 Gr. WCB	ASME A494 Gr. M35-1(9)	ASME A494 Gr. M35-1(9)	ASME SA216 Gr. WCB	ASME SA216 Gr. WCB	ASME A494 Gr. CW-12MW	ASME A494 Gr. CW-12MW
21	Bonnet Stud	ASME SA193 Gr. B7	ASME SA193 Gr. B7	304 SS	304 SS	ASME SA193 Gr. B7	ASME SA193 Gr. B7	Hastelloy C	Hastelloy C
22	Bonnet Stud Nut	ASME SA194 CL 2H	ASME SA194 CL 2H	304 SS	304 SS	ASME SA194 CL 2H	ASME SA194 CL 2H	Hastelloy C	Hastelloy C
24	Adjusting Bolt	316 SS(6)	Monel	Monel	Monel	316 SS(6)	Monel	Hastelloy C	Hastelloy C
25	Adjusting Bolt Nut	316 SS	Monel	Monel	Monel	316 SS	Monel	Hastelloy C	Hastelloy C
26	Nameplate (not shown)	SS	SS	SS	SS	SS	SS	SS	SS
27	Set Screw Gasket(1)	Organic Fiber Non-Asbestos	Organic Fiber Non-Asbestos	Organic Fiber Non-Asbestos	Organic Fiber Non-Asbestos	Organic Fiber Non-Asbestos	Organic Fiber Non-Asbestos	Organic Fiber Non-Asbestos	Organic Fiber Non-Asbestos
28	Guide Gasket(2)	Organic Fiber Non-Asbestos	Organic Fiber Non-Asbestos	Organic Fiber Non-Asbestos	Organic Fiber Non-Asbestos	Organic Fiber Non-Asbestos	Organic Fiber Non-Asbestos	Organic Fiber Non-Asbestos	Organic Fiber Non-Asbestos
29	Tailpiece Gasket(2)	Organic Fiber Non-Asbestos	Organic Fiber Non-Asbestos	Organic Fiber Non-Asbestos	Organic Fiber Non-Asbestos	Organic Fiber Non-Asbestos	Organic Fiber Non-Asbestos	Organic Fiber Non-Asbestos	Organic Fiber Non-Asbestos
34	Seal and Wire	Lead & SS	Lead & SS	Lead & SS	Lead & SS	Lead & SS	Lead & SS	Lead & SS	Lead & SS
35	Seal Clip (not shown)	SS	SS	SS	SS	SS	SS	SS	SS
40	Threaded Cap	CS	CS	Monel	Monel	CS	CS	Hastelloy C	Hastelloy C
41	Cap Gasket(2)	Organic Fiber Non-Asbestos	Organic Fiber Non-Asbestos	Organic Fiber Non-Asbestos	Organic Fiber Non-Asbestos	Organic Fiber Non-Asbestos	Organic Fiber Non-Asbestos	Organic Fiber Non-Asbestos	Organic Fiber Non-Asbestos

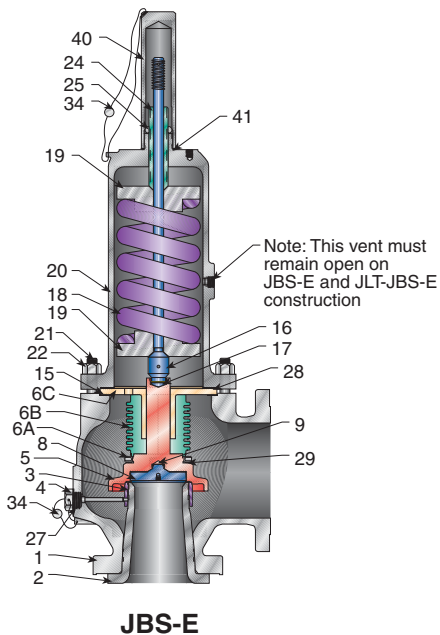

Notes

1. Subassembly.
2. Recommended Spare Part.
3. Furnished with Disc Insert.
4. Corrosion resistant coating.
5. Crosby may upgrade to Inconel® X750.
6. Class 900#, 1500#, and 2500# inlet ratings use 416 SS.
7. Temperature limit for 316 SS spring is +450°F [+232°C].
8. For temperatures above +650°F [+343°C], Crosby will supply either alloy steel nickel plated or Inconel® X750.
9. Permitted by ASME Code Case 1750-18.

Caps and Lifting Levers

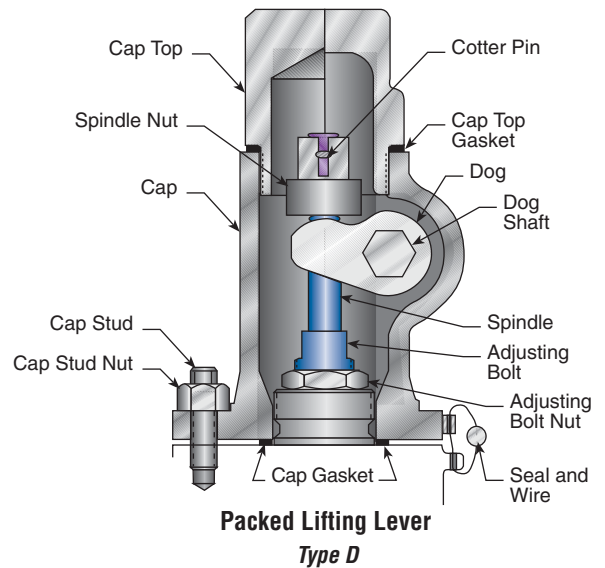
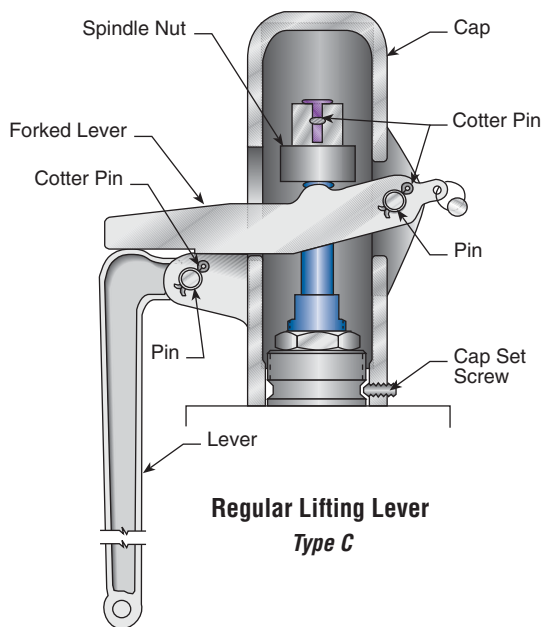
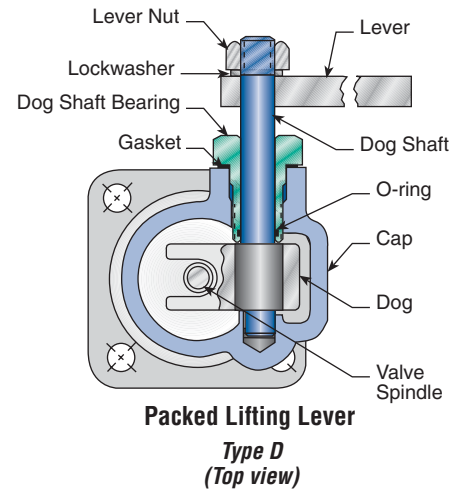
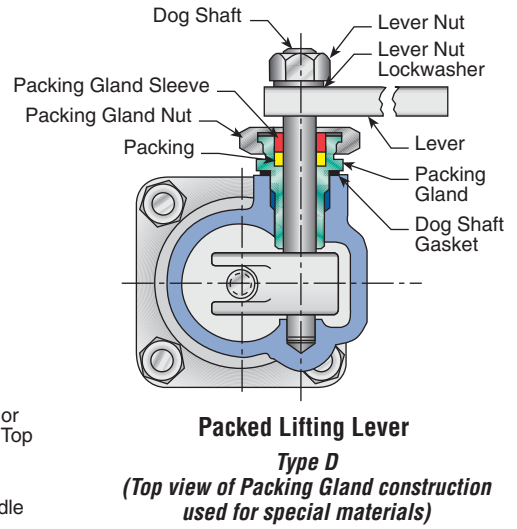
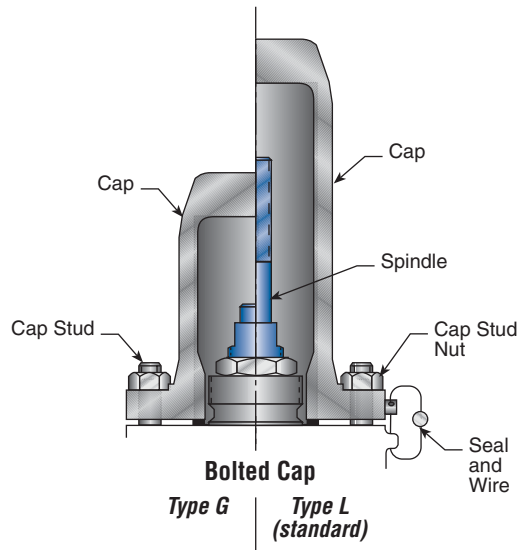
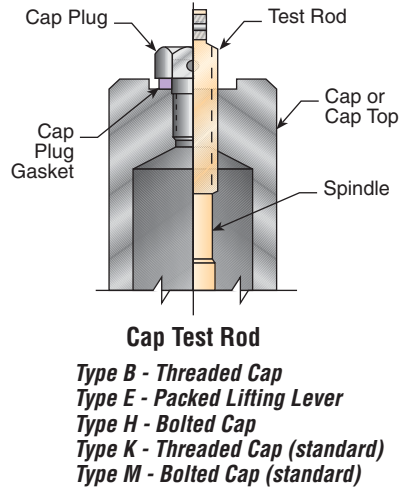
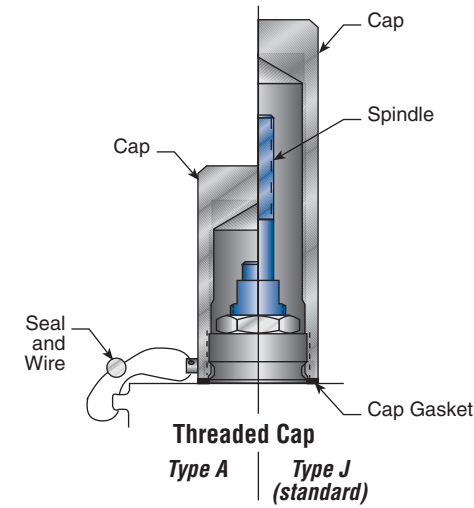

Caps and Lifting Lever Materials

Styles JOS-E/JBS-E/JLT-E pressure relief valves are regularly furnished with closed bonnet and screwed cap over the adjusting bolt. The following types of top construction are available except where otherwise indicated.

Screwed Cap (Type J Standard) - Where no lifting lever is required.

Bolted Cap (Type L) - Where no lifting lever is required. Available on special order.

Lifting Levers

Regular (Type C) - for steam and air service where the valve cap is not required to be tight on the discharge side and where conditions are such that periodic testing is desirable. Regular lifting levers may be furnished with a supplementary gagging device on special order.

Packed (Type D) - For services where tightness on the discharge side is necessary and where conditions are such that periodic testing is desirable. Also recommended for hot water services.

Test Rods

Types K, E or M - Valves with screwed caps, packed lifting levers or bolted caps can be fitted to accommodate test rods which will hold the valve closed when the equipment on which they are installed is hydrostatically tested.

Type J screwed cap changes to Type K with test rod. Type D packed lifting lever changes to Type E with test rod.

Type L bolted cap changes to Type M with test rod.

Height Restricted Applications

For applications where there are height restrictions, cap types A,B,G and H are available.

CAUTION: Test rods should never be tightened more than fingertight. Overtightening may damage internal parts. Also, a test rod should never be kept on the valve during operation of the equipment. During normal operation the test rod is replaced with cap plug and gasket to maintain tightness on the discharge side.

Ref. No. Part Name	Standard Material	Variations from Standard Materials						
	JOS/JBS-()5, 6, 7 20°F to 1000°F [-29°C to 538°C]	JOS/JBS-()4 -75°F to 21°F [-59°C to -30°C]	JOS/JBS-()2 -450°F to 76°F [-268°C to -60°C]	() ()S	() ()S4	() ()M & () ()M5 ¹	() ()M4 & () ()H4 ¹	() ()H & () ()H5 ¹
24 Cap (J, K, D, E, L, M)	CS	316 SS	316 SS	316 SS	CS	Monel	CS	Hastelloy C
Cap (C)	Malleable Iron	Malleable Iron	316 SS	316 SS	Malleable Iron	Monel	Malleable Iron	Hastelloy C
36 Cap Top (D, E)	Steel	316 SS	316 SS	316 SS	Steel	Monel	Steel	Hastelloy C
31 Cap Set Screw (C)	SS	SS	SS	SS	SS	SS	SS	Hastelloy C
40 Cap Stud	Alloy Steel	304 SS	304 SS	304 SS	Alloy Steel	304 SS	Alloy Steel	Hastelloy C
41 Cap Stud	Steel	304 SS	304 SS	304 SS	Steel	304 SS	Steel	Hastelloy C
48 Lever (D, E)	Steel	Steel	316 SS	316 SS	Steel	316 SS	Steel	316 SS
32 Lever (C), 35 Forked Lever (C)	Malleable Iron	Malleable Iron	316 SS	316 SS	Malleable Iron	316 SS	Malleable Iron	316 SS
33 Pin (Lever, Forked Lever)	Steel	Steel	SS	SS	Steel	316 SS	Steel	SS
34 Cotter Pins	Steel	Steel	SS	SS	Steel	SS	Steel	SS
49 Lever Nute (D, E)	Steel	Steel	316 SS	316 SS	316 SS	SS	316 SS	316 SS
50 Lever Nut Lockwasher	Steel	Steel	SS	SS	Steel	SS	Steel	SS
30 Spindle Nut	Steel	Steel	316 SS	316 SS	316 SS	Monel	Monel	Hastelloy C
38 Dog	Steel	Steel	316 SS	316 SS	316 SS	Monel	Monel	Hastelloy C
39 Dog Shaft	416 SS	416 SS	316 SS	316 SS	316 SS	Monel	Monel	Hastelloy C
46 Dog Shaft Bearing	416 SS	416 SS	²	²	²	²	²	²
45 Dog Shaft Bearing O-ring	Viton	Viton	²	²	²	²	²	²
57 Packing Gland	²	²	316 SS	316 SS	316 SS	Monel	Monel	Monel
58 Packing Gland Sleeve	²	²	316 SS	316 SS	416 SS	Monel	416 SS	Monel
59 Packing Gland Nut	²	²	316 SS	316 SS	Steel	Monel	Steel	Monel
56 Packing	²	²	Teflon	Teflon	Teflon	Teflon	Teflon	Teflon
27 Test Rod (K, E, M)	416 SS	416 SS	416 SS	416 SS	416 SS	416 SS	416 SS	416 SS
28 Cap Plug (K, E, M)	416 SS	416 SS	316 SS	316 SS	416 SS	Monel	416 SS	Hastelloy C
25 29 37 47 Gaskets	Organic Fiber Non-Asbestos	Organic Fiber Non-Asbestos	Organic Fiber Non-Asbestos	Organic Fiber Non-Asbestos	Organic Fiber Non-Asbestos	Organic Fiber Non-Asbestos	Organic Fiber Non-Asbestos	Organic Fiber Non-Asbestos

Notes

- Special material valves () ()M1 and () ()H1 use caps and lifting gear of standard materials.
- Packing gland construction is standard for special material valves.

Sizes and Pressure/Temperature Limits

D Orifice, 0.110 sq.in. [71 sq.mm] Effective Area

Valve Series	Valve Size Inlet X Orifice X Outlet	Standard Connections ANSI Flanges Raised Face		Maximum Set Pressure - psig							Back Press. Limit@100°F psig		Maximum Set Pressure - barg					Back Press. Limit@38°C barg					
				Inlet									Inlet										
				-450°F to -75°F	-75°F to -21°F	-20°F to +100°F	+650°F ¹	+800°F	+1000°F	-268°C to -60°C			-59°C to -30°C	-29°C to +38°C	+343°C ¹	+427°C	+538°C						
				Inlet	Outlet					JOS ²	JBS ²	JOS ²	JBS ²										
JOS-E-	15	1D2	150	150			285	125				285	230					19.6	8.62			19.6	15.8
JBS-E-	25	1D2	300	150			285	285				285	230					19.6	19.6			19.6	15.8
JLT-E-	35	1D2	300	150			740	535				285	230					51.0	36.8			19.6	15.8
JOS-H-E- ¹	45	1D2	600	150			1480	1075				285	230					102	74.1			19.6	15.8
JOS-E-	55	1½D2	900	300			2220	1610				600	600					153	111			41.3	41.3
JBS-E-	65	1½D2	1500	300			3705	2685				600	600					255	185			41.3	41.3
JLT-E-	75	1½D3	2500	300			6000	4475				740	600					413	308			51.0	41.3
JOS-E-	16	1D2	150	150				125	80			285	230					8.62	5.51			19.6	15.8
JBS-E-	26	1D2	300	150				285	285			285	230					19.6	19.6			19.6	15.8
JLT-E-	36	1D2	300	150				535	410			285	230					36.8	28.2			19.6	15.8
JOS-H-E-	46	1D2	600	150				1075	825			285	230					74.1	56.8			19.6	15.8
JOS-E-	56	1½D2	900	300				1610	1235			600	600					111	85.1			41.3	41.3
JBS-E-	66	1½D2	1500	300				2685	2060			600	600					185	142			41.3	41.3
JLT-E-	76	1½D3	2500	300				4475	3430			740	600					308	236			51.0	41.3
JOS-E-	37	1D2	300	150					510	215		285	230							35.1	14.8	19.6	15.8
JLT-E-	47	1D2	600	150					1015	430		285	230							70	29.6	19.6	15.8
JOS-H-E-																							
JOS-E-	57	1½D2	900	300					1525	650		600	600							105	44.8	41.3	41.3
JBS-E-	67	1½D2	1500	300					2540	1080		600	600							175	74.4	41.3	41.3
JLT-E-	77	1½D3	2500	300					4230	1800		740	600							291	124	51.0	41.3
JOS-E-	14	1D2	150	150		275						275	230									18.9	15.8
JBS-E-	24	1D2	300	150		275						275	230									18.9	15.8
JLT-E-	34	1D2	300	150		720						275	230									18.9	15.8
JLT-E-	44	1D2	600	150		1440						275	230									18.9	15.8
JOS-E-	12	1D2	150	150	275							275	230	18.9								18.9	15.8
JBS-E-	22	1D2	300	150	275							275	230	18.9								18.9	15.8
JLT-E-	32	1D2	300	150	720							275	230	49.6								18.9	15.8
JLT-E-	42	1D2	600	150	1440							275	230	99.3								18.9	15.8

Notes

- Upper temperature limit of JOS-H-E-15, 25, 35 and 45 valves is +800°F [+427°C].
- Outlet pressure for temperatures above +100°F [+38°C] should not exceed the ANSI flange rating.
- Valves set below 15 psig [1.03 barg] cannot be stamped with the ASME Code Symbol. Only metal seated valves may be set below 15 psig.
- Series Designations: JLT-JOS-E and JLT-JBS-E signify Series JOS-E, JBS-E with liquid trim for liquid and gas service.

Low Set Pressure Limits

JOS-E	10 psig [0.68 barg]
JBS-E	25 psig [1.72 barg]
JLT-JOS-E	15 psig [1.03 barg]
JLT-JBS-E	25 psig [1.72 barg]

Dimensions and Weights

Valve Series	Valve Dimensions, inches [mm]								Approx. Weight lbs (kg) Type J
	Center to Face		Use to find Bolt Length	Approximate Height					
	Inlet	Outlet		Valve (Cap) Type					
	E	F	X	A & G	J & L	C	D		
JOS-E-, JBS-E-, JLT-E-, JOS-H-E-									
12, 14, 15, 16, 22, 24, 25, 26	4 1/8 [105]	4 1/2 [114]	1 9/16 [40]	4 1/8 [105]	19 3/4 [502]	19 [483]	19 1/2 [495]	36 (16)	
32, 34, 35, 36, 37	4 1/8 [105]	4 1/2 [114]	1 9/16 [40]	4 1/8 [105]	19 3/4 [502]	19 [483]	19 1/2 [495]	36 (16)	
42, 44, 45, 46, 47	4 1/8 [105]	4 1/2 [114]	1 9/16 [40]	4 1/8 [105]	19 3/4 [502]	19 [483]	19 1/2 [495]	36 (16)	
JOS-E-, JBS-E-, JLT-E-									
55, 56, 57, 65, 66, 67	4 1/8 [105]	5 1/2 [140]	2 [51]	4 1/8 [105]	20 1/2 [521]	19 3/4 [502]	20 1/4 [514]	65 (29)	
75, 76, 77	5 1/2 [140]	7 [178]	2 1/2 [64]	5 1/2 [140]	21 3/4 [552]	21 [533]	21 1/2 [546]	75 (34)	

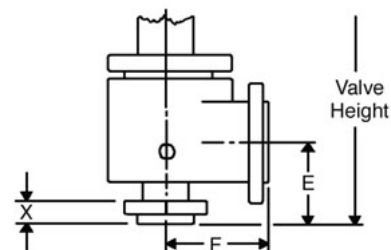

- Type J (Threaded Cap)
- Type C (Regular Lifting Lever) Also JOS-H-E
- Type D (Packed Lifting Lever)
- Type L (Bolted Cap)

Pressure/Temperature Limit Chart - To ANSI Class 600

D Orifice, 0.110 sq.in. [71 sq.mm] Effective Area

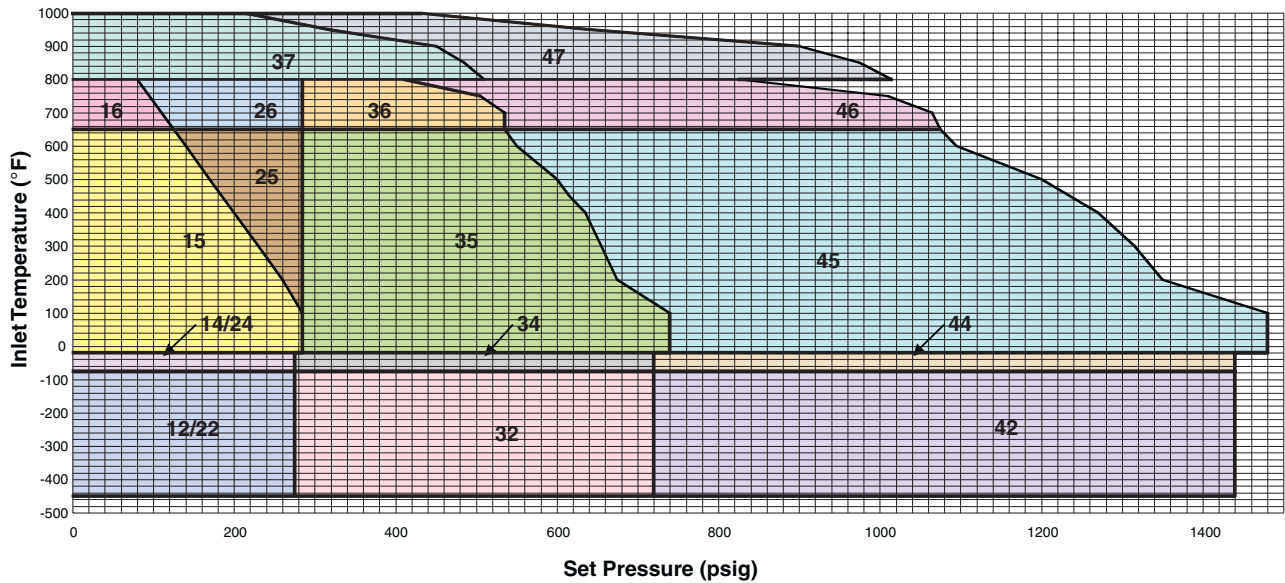

Pressure/Temperature Limit Chart - ANSI Class 900, Class 1500, Class 2500

D Orifice, 0.110 sq.in. [71 sq.mm] Effective Area

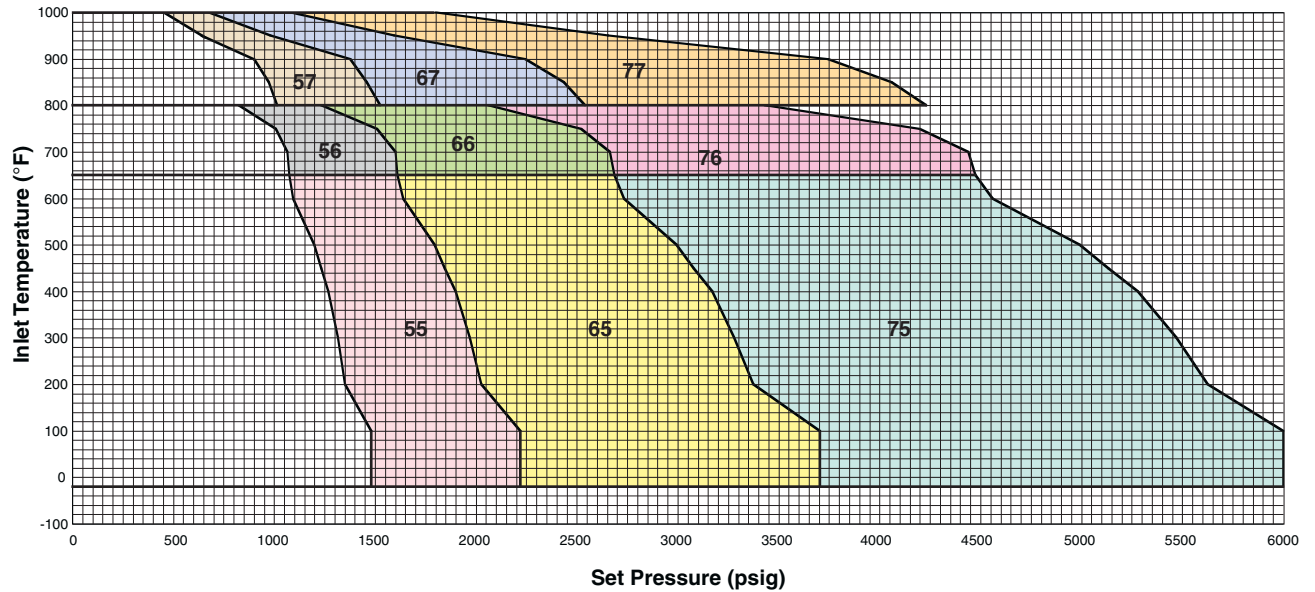

Sizes and Pressure/Temperature Limits

E Orifice, 0.196 sq.in. [126 sq.mm] Effective Area

Valve Series	Valve Size Inlet X Orifice X Outlet	Standard Connections ANSI Flanges Raised Face		Maximum Set Pressure - psig							Back Press. Limit@100°F psig		Maximum Set Pressure - barg						Back Press. Limit@38°C barg										
				Inlet									Inlet																
				-450°F to -75°F	-75°F to -21°F	-20°F to +100°F	+650°F ¹	+800°F	+1000°F	JOS ²			JBS ²	-268°C to -60°C	-59°C to -30°C	-29°C to +38°C	+343°C ¹	+427°C			+538°C	JOS ²	JBS ²						
											Inlet	Outlet							-268°C to -60°C	-59°C to -30°C				-29°C to +38°C	+343°C ¹	+427°C	+538°C		
JOS-E-	15	1E2	150	150			285	125								285	230									19.6	15.8		
JBS-E-	25	1E2	300	150			285	285								285	230									19.6	15.8		
JLT-E-	35	1E2	300	150			740	535								285	230								51.0	36.8	19.6	15.8	
JOS-H-E-	45	1E2	600	150			1480	1075								285	230								102	74.1	19.6	15.8	
JOS-E-	55	1½E2	900	300			2220	1610								600	600								153	111	41.3	41.3	
JBS-E-	65	1½E2	1500	300			3705	2685								600	600								255	185	41.3	41.3	
JLT-E-	75	1½E3	2500	300			6000	4475								740	600								413	308	51.0	41.3	
JOS-E-	16	1E2	150	150				125	80							285	230								8.62	5.51	19.6	15.8	
JBS-E-	26	1E2	300	150				285	285							285	230								19.6	19.6	19.6	15.8	
JLT-E-	36	1E2	300	150				535	410							285	230								36.8	28.2	19.6	15.8	
JOS-H-E-	46	1E2	600	150				1075	825							285	230								74.1	56.8	19.6	15.8	
JOS-E-	56	1½E2	900	300				1610	1235							600	600								111	85.1	41.3	41.3	
JBS-E-	66	1½E2	1500	300				2685	2060							600	600								185	142	41.3	41.3	
JLT-E-	76	1½E3	2500	300				4475	3430							740	600								308	236	51.0	41.3	
JOS-E-	37	1E2	300	150					510	215						285	230									35.1	14.8	19.6	15.8
JLT-E-	47	1E2	600	150					1015	430						285	230									70	29.6	19.6	15.8
JOS-H-E-																													
JOS-E-	57	1½E2	900	300					1525	650						600	600									105	44.8	41.3	41.3
JBS-E-	67	1½E2	1500	300					2540	1080						600	600									175	74.4	41.3	41.3
JLT-E-	77	1½E3	2500	300					4230	1800						740	600									291	124	51.0	41.3
JOS-E-	14	1E2	150	150		275										275	230											18.9	15.8
JBS-E-	24	1E2	300	150		275										275	230											18.9	15.8
JLT-E-	34	1E2	300	150		720										275	230											18.9	15.8
JLT-E-	44	1E2	600	150		1440										275	230											18.9	15.8
JOS-E-	12	1E2	150	150	275											275	230	18.9										18.9	15.8
JBS-E-	22	1E2	300	150	275											275	230	18.9										18.9	15.8
JLT-E-	32	1E2	300	150	720											275	230	49.6										18.9	15.8
JLT-E-	42	1E2	600	150	1440											275	230	99.3										18.9	15.8

Notes

- Upper temperature limit of JOS-H-E-15, 25, 35 and 45 valves is +800°F [+427°C].
- Outlet pressure for temperatures above +100°F [+38°C] should not exceed the ANSI flange rating.
- Valves set below 15 psig [1.03 barg] cannot be stamped with the ASME Code Symbol. Only metal seated valves may be set below 15 psig.
- Series Designations: JLT-JOS-E and JLT-JBS-E signify Series JOS-E, JBS-E with liquid trim for liquid and gas service.

Low Set Pressure Limits

JOS-E	8 psig [0.55 barg]
JBS-E	25 psig [1.72 barg]
JLT-JOS-E	15 psig [1.03 barg]
JLT-JBS-E	25 psig [1.72 barg]

Dimensions and Weights

Valve Series	Valve Dimensions, inches [mm]								Approx. Weight lbs (kg) Type J
	Center to Face		Use to find Bolt Length X	Approximate Height					
	Inlet	Outlet		Valve (Cap) Type					
				E	F	A & G	J & L	C	
JOS-E-, JBS-E-, JLT-E-, JOS-H-E-									
12, 14, 15, 16, 22, 24, 25, 26	4⅛ [105]	4½ [114]	19/16 [40]	16¾ [426]	19¾ [502]	19 [483]	19½ [495]	36 (16)	
32, 34, 35, 36, 37	4⅛ [105]	4½ [114]	19/16 [40]	16¾ [426]	19¾ [502]	19 [483]	19½ [495]	36 (16)	
42, 44, 45, 46, 47	4⅛ [105]	4½ [114]	19/16 [40]	16¾ [426]	19¾ [502]	19 [483]	19½ [495]	36 (16)	
JOS-E-, JBS-E-, JLT-E-									
55, 56, 57, 65, 66, 67	4⅛ [105]	5½ [140]	2 [51]	17½ [445]	20½ [521]	19¾ [502]	20¼ [514]	65 (29)	
75, 76, 77	5½ [140]	7 [178]	2½ [64]	18¾ [477]	21¾ [552]	21 [533]	21½ [546]	75 (34)	

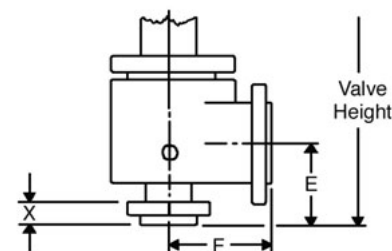

- Type J (Threaded Cap)
- Type C (Regular Lifting Lever) Also JOS-H-E
- Type D (Packed Lifting Lever)
- Type L (Bolted Cap)

Pressure/Temperature Limit Chart - To ANSI Class 600

E Orifice, 0.196 sq.in. [126 sq.mm] Effective Area

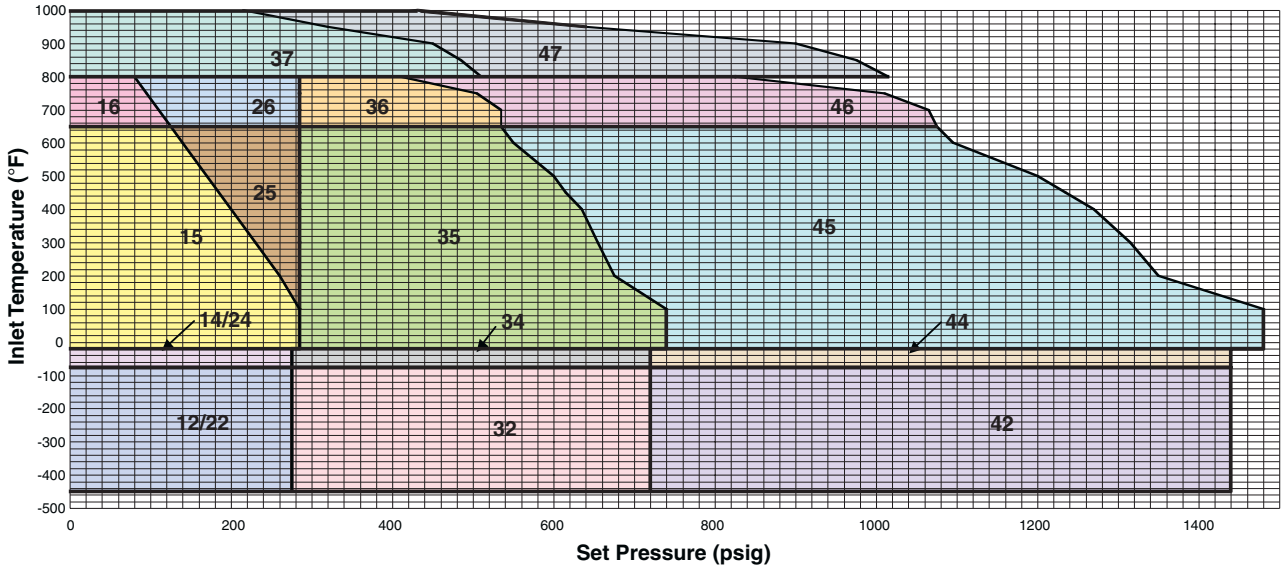

Pressure/Temperature Limit Chart - ANSI Class 900, Class 1500, Class 2500

E Orifice, 0.196 sq.in. [126 sq.mm] Effective Area

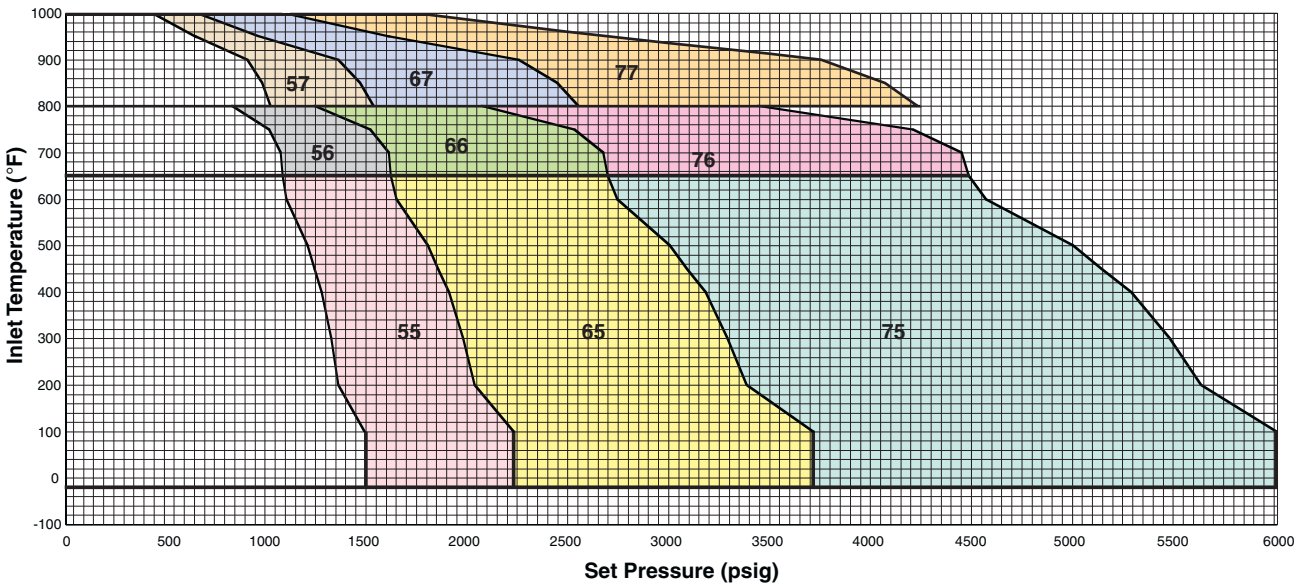

Sizes and Pressure/Temperature Limits

F Orifice, 0.307 sq.in. [198 sq.mm] Effective Area

Valve Series	Valve Size Inlet X Orifice X Outlet	Standard Connections ANSI Flanges Raised Face		Maximum Set Pressure - psig							Back Press. Limit@100°F psig		Maximum Set Pressure - barg						Back Press. Limit@38°C barg				
				Inlet									Inlet										
				-450°F to -75°F	-75°F to -21°F	-20°F to +100°F	+650°F ¹	+800°F	+1000°F	-268°C to -60°C			-59°C to -30°C	-29°C to +38°C	+343°C ¹	+427°C	+538°C						
				Inlet	Outlet	JOS ²	JBS ²	JOS ²	JBS ²	JOS ²	JBS ²												
JOS-E-	15	1 1/2F2	150	150			285	125			285	230					19.6	8.62			19.6	15.8	
JBS-E-	25	1 1/2F2	300	150			285	285			285	230					19.6	19.6			19.6	15.8	
JLT-E-	35	1 1/2F2	300	150			740	535			285	230					51.0	36.8			19.6	15.8	
JOS-H-E-	45	1 1/2F2	600	150			1480	1075			285	230					102	74.1			19.6	15.8	
JOS-E-	55	1 1/2F3	900	300			2220	1610			740	500					153	111			51.0	34.4	
JBS-E-	65	1 1/2F3	1500	300			3705	2685			740	500					255	185			51.0	34.4	
JLT-E-	75	1 1/2F3	2500	300			5000	4475			740	500					344	308			51.0	34.4	
JOS-E-	16	1 1/2F2	150	150				125	80		285	230						8.62	5.51			19.6	15.8
JBS-E-	26	1 1/2F2	300	150				285	285		285	230						19.6	19.6			19.6	15.8
JLT-E-	36	1 1/2F2	300	150				535	410		285	230						36.8	28.2			19.6	15.8
JOS-H-E-	46	1 1/2F2	600	150				1075	825		285	230						74.1	56.8			19.6	15.8
JOS-E-	56	1 1/2F3	900	300				1610	1235		740	500						111	85.1			51.0	34.4
JBS-E-	66	1 1/2F3	1500	300				2685	2060		740	500						185	142			51.0	34.4
JLT-E-	76	1 1/2F3	2500	300				4475	3430		740	500						308	236			51.0	34.4
JOS-E-	37	1 1/2F2	300	150					510	215	285	230								35.1	14.8	19.6	15.8
JLT-E-	47	1 1/2F2	600	150					1015	430	285	230								70	29.6	19.6	15.8
JOS-H-E-																							
JOS-E-	57	1 1/2F3	900	300					1525	650	740	500								105	44.8	51.0	34.4
JBS-E-	67	1 1/2F3	1500	300					2540	1080	740	500								175	74.4	51.0	34.4
JLT-E-	77	1 1/2F3	2500	300					4230	1800	740	500								291	124	51.0	34.4
JOS-E-	14	1 1/2F2	150	150		275					275	230		18.9								18.9	15.8
JBS-E-	24	1 1/2F2	300	150		275					275	230		18.9								18.9	15.8
JLT-E-	34	1 1/2F2	300	150		720					275	230		49.6								18.9	15.8
JLT-E-	44	1 1/2F2	600	150		1440					275	230		99.3								18.9	15.8
JOS-E-	12	1 1/2F2	150	150	275						275	230	18.9									18.9	15.8
JBS-E-	22	1 1/2F2	300	150	275						275	230	18.9									18.9	15.8
JLT-E-	32	1 1/2F2	300	150	720						275	230	49.6									18.9	15.8
JLT-E-	42	1 1/2F2	600	150	1440						275	230	99.3									18.9	15.8

Notes

- Upper temperature limit of JOS-H-E-15, 25, 35 and 45 valves is +800°F [+427°C].
- Outlet pressure for temperatures above +100°F [+38°C] should not exceed the ANSI flange rating.
- Valves set below 15 psig [1.03 barg] cannot be stamped with the ASME Code Symbol. Only metal seated valves may be set below 15 psig.
- Series Designations: JLT-JOS-E and JLT-JBS-E signify Series JOS-E, JBS-E with liquid trim for liquid and gas service.

Low Set Pressure Limits

JOS-E	5 psig [0.34 barg]
JBS-E	10 psig [0.68 barg]
JLT-JOS-E	15 psig [1.03 barg]
JLT-JBS-E	25 psig [1.72 barg]

Dimensions and Weights

Valve Series	Valve Dimensions, inches [mm]								Approx. Weight lbs (kg) Type J
	Center to Face		Use to find Bolt Length	Approximate Height					
	Inlet	Outlet		Valve (Cap) Type					
	E	F	X	A & G	J & L	C	D		
JOS-E-, JBS-E-, JLT-E-, JOS-H-E-									
12, 14, 15, 16, 22, 24, 25, 26	4 7/8 [124]	4 3/4 [121]	1 3/4 [44]	20 1/4 [515]	23 1/4 [591]	22 1/2 [572]	23 1/4 [591]	50 (23)	
32, 34, 35, 36, 37	4 7/8 [124]	6 [152]	1 3/4 [44]	20 1/4 [515]	23 1/4 [591]	22 1/2 [572]	23 1/4 [591]	50 (23)	
42, 44, 45, 46, 47	4 7/8 [124]	6 [152]	1 3/4 [44]	20 1/4 [515]	23 1/4 [591]	22 1/2 [572]	23 1/4 [591]	50 (23)	
55, 56, 57, 65, 66, 67	4 7/8 [124]	6 1/2 [165]	2 [51]	20 [508]	23 [584]	21 1/4 [540]	21 3/4 [552]	65 (29)	
75, 76, 77	5 1/2 [140]	7 [178]	2 1/2 [64]	23 [584]	26 3/4 [679]	26 [660]	26 3/4 [679]	85 (39)	

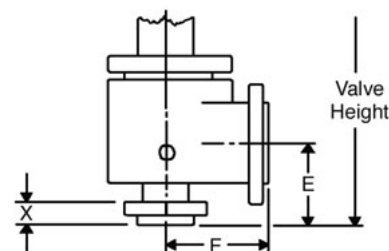

- Type J (Threaded Cap)
- Type C (Regular Lifting Lever) Also JOS-H-E
- Type D (Packed Lifting Lever)
- Type L (Bolted Cap)

Pressure/Temperature Limit Chart - To ANSI Class 600

F Orifice, 0.307 sq.in. [198 sq.mm] Effective Area

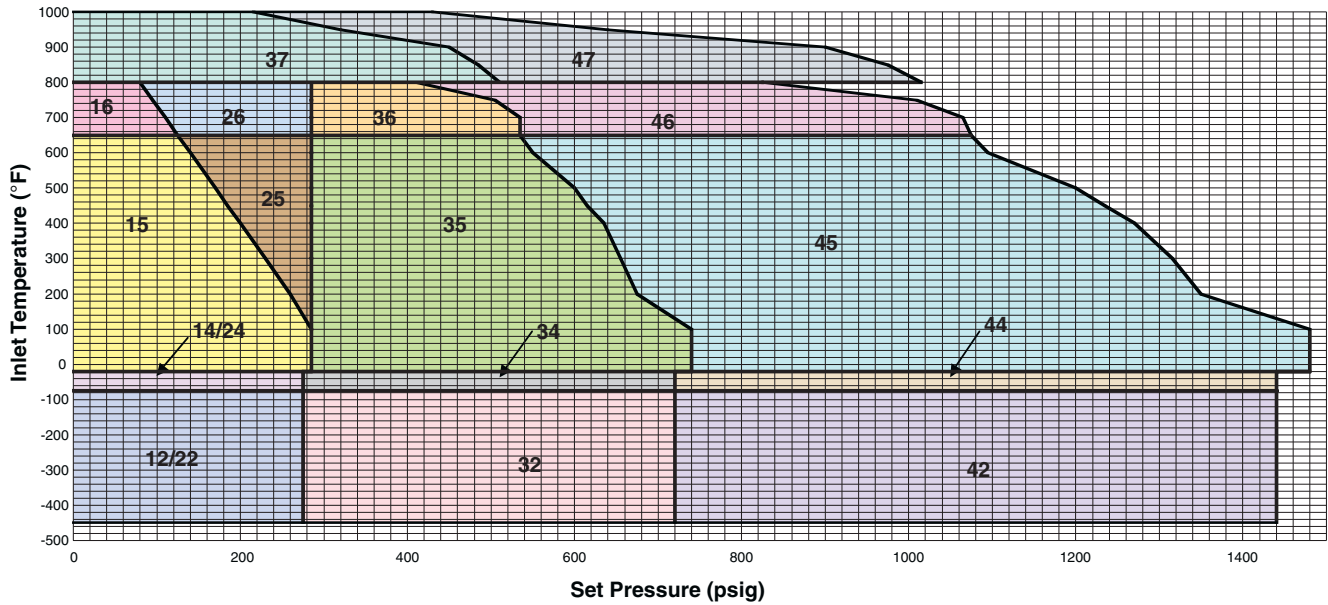

Pressure/Temperature Limit Chart - ANSI Class 900, Class 1500, Class 2500

F Orifice, 0.307 sq.in. [198 sq.mm] Effective Area

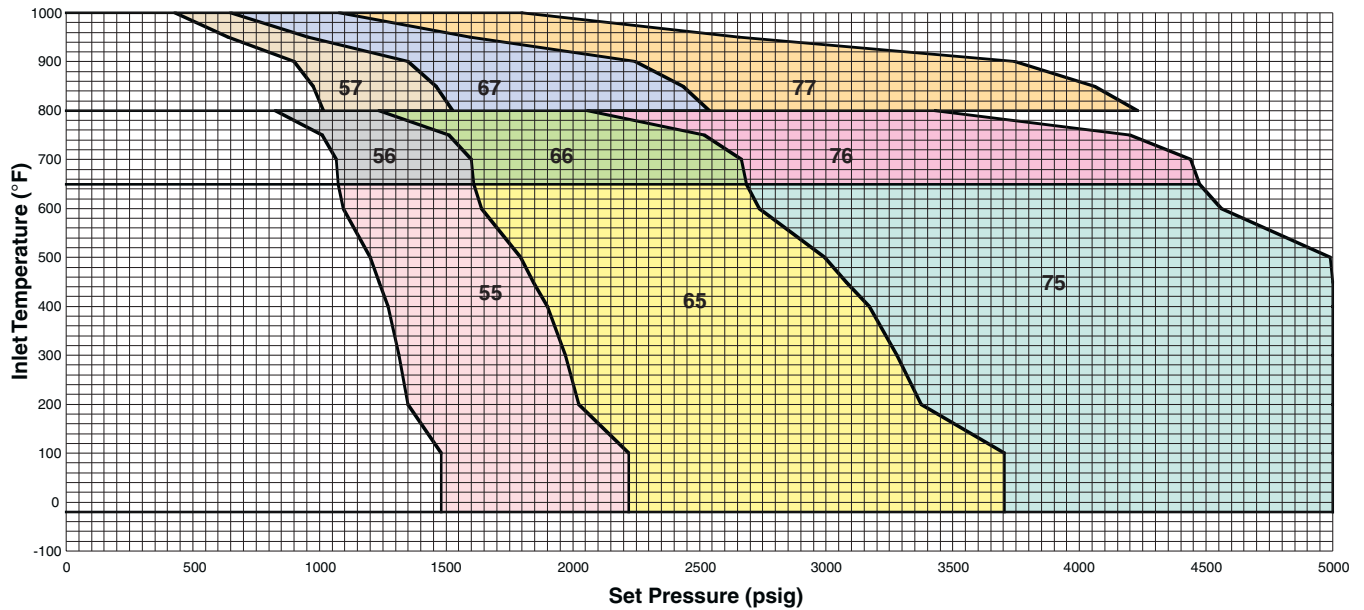

Sizes and Pressure/Temperature Limits

G Orifice, 0.503 sq.in. [325 sq.mm] Effective Area

Valve Series	Valve Size Inlet X Orifice X Outlet	Standard Connections ANSI Flanges Raised Face		Maximum Set Pressure - psig							Back Press. Limit@100°F psig		Maximum Set Pressure - barg						Back Press. Limit@38°C barg			
				Inlet									Inlet									
				Inlet	Outlet	-450°F to -75°F	-75°F to -21°F	-20°F to +100°F	+650°F ¹	+800°F			+1000°F	-268°C to -60°C	-59°C to -30°C	-29°C to +38°C	+343°C ¹	+427°C			+538°C	JOS ²
						JOS ²	JBS ²	-268°C to -60°C	-59°C to -30°C	-29°C to +38°C	+343°C ¹	+427°C	+538°C	JOS ²	JBS ²							
JOS-E-15	15	1 1/2G3	150	150			285	125			285	230				19.6	8.62			19.6	15.8	
JBS-E-25	25	1 1/2G3	300	150			285	285			285	230				19.6	19.6			19.6	15.8	
JLT-E-35	35	1 1/2G3	300	150			740	535			285	230				51.0	36.8			19.6	15.8	
JOS-H-E-45	45	1 1/2G3	600	150			1480	1075			285	230				102	74.1			19.6	15.8	
JOS-E-55	55	1 1/2G3	900	300			2220	1610			740	470				153	111			51.0	32.4	
JBS-E-65	65	2G3	1500	300			3705	2685			740	470				255	185			51.0	32.4	
JLT-E-75	75	2G3	2500	300			3705	3705			740	470				255	255			51.0	32.4	
JOS-E-16	16	1 1/2G3	150	150				125	80		285	230				8.62	5.51			19.6	15.8	
JBS-E-26	26	1 1/2G3	300	150				285	285		285	230				19.6	19.6			19.6	15.8	
JLT-E-36	36	1 1/2G3	300	150				535	410		285	230				36.8	28.2			19.6	15.8	
JOS-H-E-46	46	1 1/2G3	600	150				1075	825		285	230				74.1	56.8			19.6	15.8	
JOS-E-56	56	1 1/2G3	900	300				1610	1235		740	470				111	85.1			51.0	32.4	
JBS-E-66	66	2G3	1500	300				2685	2060		740	470				185	142			51.0	32.4	
JLT-E-76	76	2G3	2500	300				3705	3430		740	470				255	236			51.0	32.4	
JOS-E-37	37	1 1/2G3	300	150					510	215	285	230							35.1	14.8	19.6	15.8
JLT-E-47	47	1 1/2G3	600	150					1015	430	285	230							70	29.6	19.6	15.8
JOS-H-E-57	57	1 1/2G3	900	300					1525	650	740	470							105	44.8	51.0	32.4
JBS-E-67	67	2G3	1500	300					2540	1080	740	470							175	74.4	51.0	32.4
JLT-E-77	77	2G3	2500	300					3705	1800	740	500							255	124	51.0	32.4
JOS-E-14	14	1 1/2G3	150	150		275					275	230		18.9						18.9	15.8	
JBS-E-24	24	1 1/2G3	300	150		275					275	230		18.9						18.9	15.8	
JOS-E-34	34	1 1/2G3	300	150		720					275	230		49.6						18.9	15.8	
JLT-E-44	44	1 1/2G3	600	150		1440					275	230		99.3						18.9	15.8	
JOS-E-12	12	1 1/2G3	150	150	275						275	230	18.9							18.9	15.8	
JBS-E-22	22	1 1/2G3	300	150	275						275	230	18.9							18.9	15.8	
JOS-E-32	32	1 1/2G3	300	150	720						275	230	49.6							18.9	15.8	
JLT-E-42	42	1 1/2G3	600	150	1440						275	230	99.3							18.9	15.8	

Notes

- Upper temperature limit of JOS-H-E-15, 25, 35 and 45 valves is +800°F [+427°C].
- Outlet pressure for temperatures above +100°F [+38°C] should not exceed the ANSI flange rating.
- Valves set below 15 psig [1.03 barg] cannot be stamped with the ASME Code Symbol. Only metal seated valves may be set below 15 psig.
- Series Designations: JLT-JOS-E and JLT-JBS-E signify Series JOS-E, JBS-E with liquid trim for liquid and gas service.

Low Set Pressure Limits

JOS-E	5 psig [0.34 barg]
JBS-E	15 psig [1.03 barg]
JLT-JOS-E	15 psig [1.03 barg]
JLT-JBS-E	25 psig [1.72 barg]

Dimensions and Weights

Valve Series	Valve Dimensions, inches [mm]								Approx. Weight lbs (kg) Type J
	Center to Face		Use to find Bolt Length X	Approximate Height					
	Inlet	Outlet		Valve (Cap) Type					
				E	F	A & G	J & L	C	
JOS-E-, JBS-E-, JLT-E-, JOS-H-E-									
12, 14, 15, 16, 22, 24, 25, 26	47/8 [124]	43/4 [121]	13/4 [44]	201/4 [515]	231/4 [591]	221/2 [572]	231/4 [591]	50 (23)	
32, 34, 35, 36, 37, 47	47/8 [124]	6 [152]	13/4 [44]	201/4 [515]	231/4 [591]	221/2 [572]	231/4 [591]	50 (23)	
42, 44, 45, 46	47/8 [124]	6 [152]	13/4 [44]	201/4 [515]	231/4 [591]	221/2 [572]	231/4 [591]	50 (23)	
55, 56, 57	47/8 [124]	61/2 [165]	2 [51]	221/4 [566]	26 [660]	251/4 [641]	26 [660]	70 (32)	
65, 66, 67, 75, 76, 77	61/8 [140]	63/4 [171]	23/4 [70]	231/4 [591]	27 [686]	261/4 [667]	27 [686]	90 (41)	

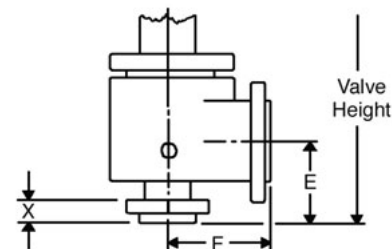

- Type J (Threaded Cap)
- Type C (Regular Lifting Lever) Also JOS-H-E
- Type D (Packed Lifting Lever)
- Type L (Bolted Cap)

Pressure/Temperature Limit Chart - To ANSI Class 600

G Orifice, 0.503 sq.in. [325 sq.mm] Effective Area

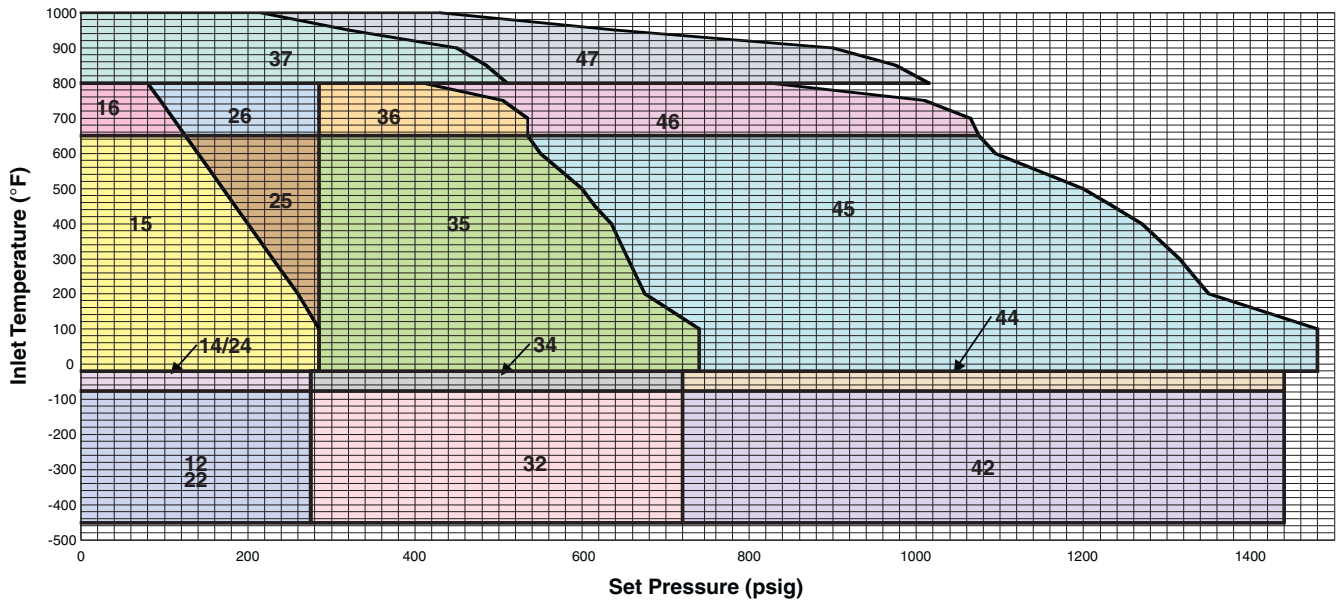

Pressure/Temperature Limit Chart - ANSI Class 900, Class 1500, Class 2500

G Orifice, 0.503 sq.in. [325 sq.mm] Effective Area

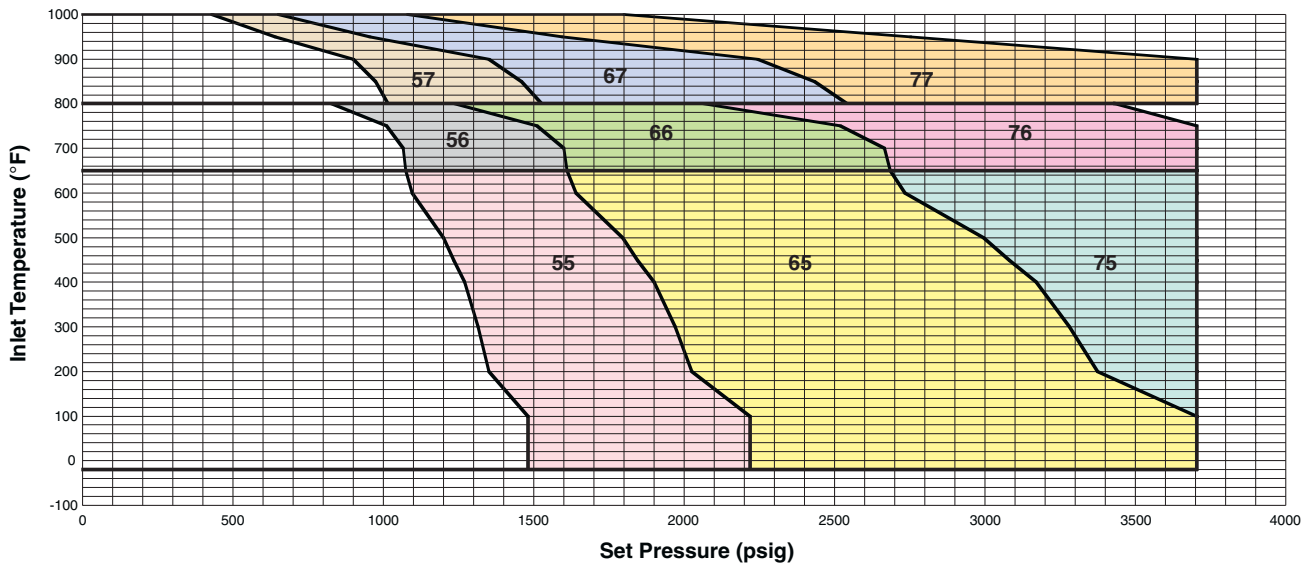

Sizes and Pressure/Temperature Limits

H Orifice, 0.785 sq.in. [506 sq.mm] Effective Area

Valve Series	Valve Size Inlet X Orifice X Outlet	Standard Connections ANSI Flanges Raised Face		Maximum Set Pressure - psig							Back Press. Limit@100°F psig		Maximum Set Pressure - barg					Back Press. Limit@38°C barg		
				Inlet									Inlet							
				Inlet	Outlet	-450°F to -75°F	-75°F to -21°F	-20°F to +100°F	+650°F ¹	+800°F			+1000°F	-268°C to -60°C	-59°C to -30°C	-29°C to +38°C	+343°C ¹			+427°C
											JOS ²	JBS ²						JOS ²	JBS ²	
JOS-E-15	15	1 1/2H3	150	150			285	125			285	230			19.6	8.62			19.6	15.8
JBS-E-25	25	1 1/2H3	300	150			285	285			285	230			19.6	19.6			19.6	15.8
JLT-E-35	35	2H3	300	150			740	535			285	230			51.0	36.8			19.6	15.8
JOS-H-E-45	45	2H3	600	150			1480	1075			285	230			102	74.1			19.6	15.8
JOS-E-55	55	2H3	900	150			2220	1610			285	230			153	111			19.6	15.8
JBS-E-65	65	2H3	1500	300			2750	2685			740	415			189	185			51.0	28.6
JOS-E-16	16	1 1/2H3	150	150				125	80		285	230				8.62	5.51		19.6	15.8
JBS-E-26	26	1 1/2H3	300	150				285	285		285	230				19.6	19.6		19.6	15.8
JLT-E-36	36	2H3	300	150				535	410		285	230				36.8	28.2		19.6	15.8
JOS-H-E-46	46	2H3	600	150				1075	825		285	230				74.1	56.8		19.6	15.8
JOS-E-56	56	2H3	900	150				1610	1235		285	230				111	85.1		19.6	15.8
JBS-E-66	66	2H3	1500	300				2685	2060		740	415				185	142		51.0	28.6
JOS-E-37	37	2H3	300	150					510	215	285	230					35.1	14.8	19.6	15.8
JLT-E-47	47	2H3	600	150					815	430	285	230					56.2	29.6	19.6	15.8
JOS-H-E-57	57	2H3	900	150					1225	650	285	230					84.4	44.8	19.6	15.8
JBS-E-67	67	2H3	1500	300					2040	1080	740	415					140	74.4	51.0	28.6
JOS-E-14	14	1 1/2H3	150	150		275					275	230		18.9					18.9	15.8
JBS-E-24	24	1 1/2H3	300	150		275					275	230		18.9					18.9	15.8
JLT-E-34	34	2H3	300	150		720					275	230		49.6					18.9	15.8
JLT-E-44	44	2H3	600	150		1440					275	230		99.3					18.9	15.8
JOS-E-12	12	1 1/2H3	150	150	275						275	230	18.9						18.9	15.8
JBS-E-22	22	1 1/2H3	300	150	275						275	230	18.9						18.9	15.8
JLT-E-32	32	2H3	300	150	720						275	230	49.6						18.9	15.8
JLT-E-42	42	2H3	600	150	1440						275	230	99.3						18.9	15.8

Notes

- Upper temperature limit of JOS-H-E-15, 25, 35 and 45 valves is +800°F [+427°C].
- Outlet pressure for temperatures above +100°F [+38°C] should not exceed the ANSI flange rating.
- Valves set below 15 psig [1.03 barg] cannot be stamped with the ASME Code Symbol. Only metal seated valves may be set below 15 psig.
- Series Designations: JLT-JOS-E and JLT-JBS-E signify Series JOS-E, JBS-E with liquid trim for liquid and gas service.

Low Set Pressure Limits

JOS-E	5 psig [0.34 barg]
JBS-E	10 psig [0.68 barg]
JLT-JOS-E	15 psig [1.03 barg]
JLT-JBS-E	25 psig [1.72 barg]

Dimensions and Weights

Valve Series	Valve Dimensions, inches [mm]							Approx. Weight lbs (kg) Type J
	Center to Face		Use to find Bolt Length	Approximate Height				
	Inlet	Outlet		Valve (Cap) Type				
			E	F	X	A & G	J & L	
JOS-E-, JBS-E-, JLT-E-, JOS-H-E-								
12, 14, 15, 16, 22, 24, 25, 26	5 1/8 [130]	4 7/8 [124]	1 11/16 [43]	20 1/2 [521]	23 1/2 [597]	22 3/4 [578]	23 1/4 [591]	55 (25)
32, 34, 35, 36, 37, 47	5 1/8 [130]	4 7/8 [124]	1 13/16 [46]	20 1/2 [521]	23 1/2 [597]	22 3/4 [578]	23 1/4 [591]	60 (27)
42, 44, 45, 46	6 1/16 [154]	6 3/8 [162]	1 13/16 [46]	23 [585]	26 3/4 [679]	26 [660]	26 3/4 [679]	75 (34)
55, 56, 57, 65, 66, 67	6 1/16 [154]	6 3/8 [162]	2 5/16 [59]	24 1/2 [623]	28 1/4 [718]	27 1/2 [699]	28 1/4 [718]	100 (50)

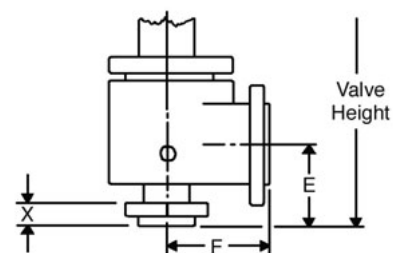

- Type J (Threaded Cap)
- Type C (Regular Lifting Lever) Also JOS-H-E
- Type D (Packed Lifting Lever)
- Type L (Bolted Cap)

Pressure/Temperature Limit Chart - To ANSI Class 600

H Orifice, 0.785 sq.in. [506 sq.mm] Effective Area

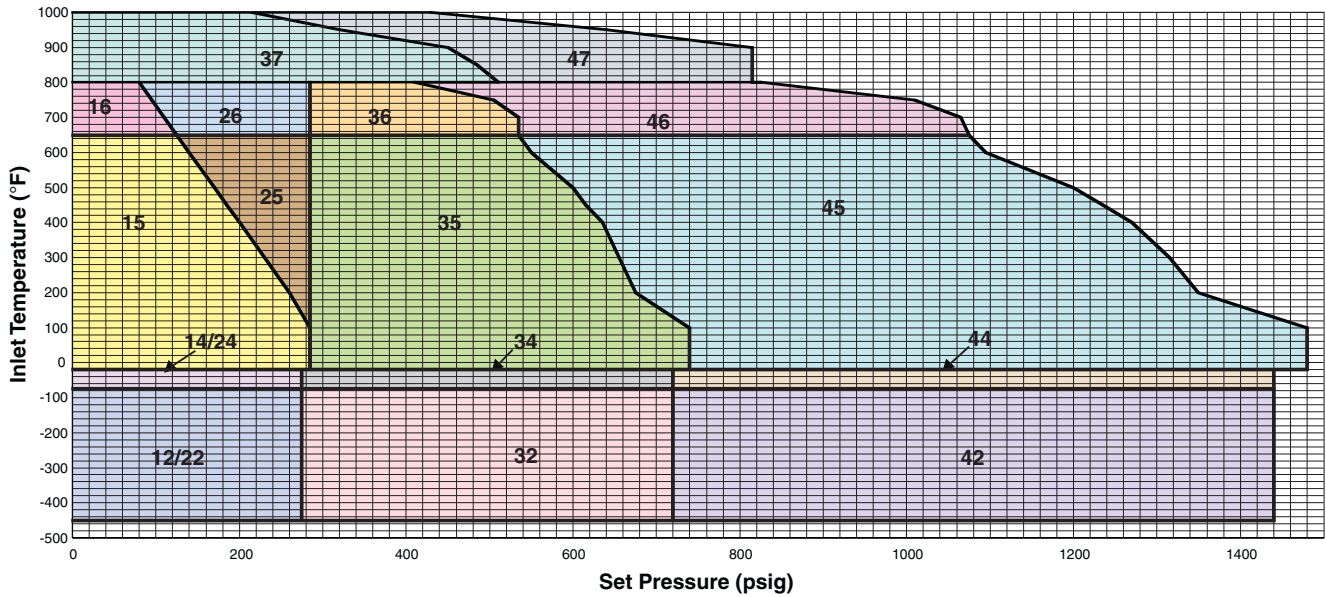

Pressure/Temperature Limit Chart - ANSI Class 900, Class 1500

H Orifice, 0.785 sq.in. [506 sq.mm] Effective Area

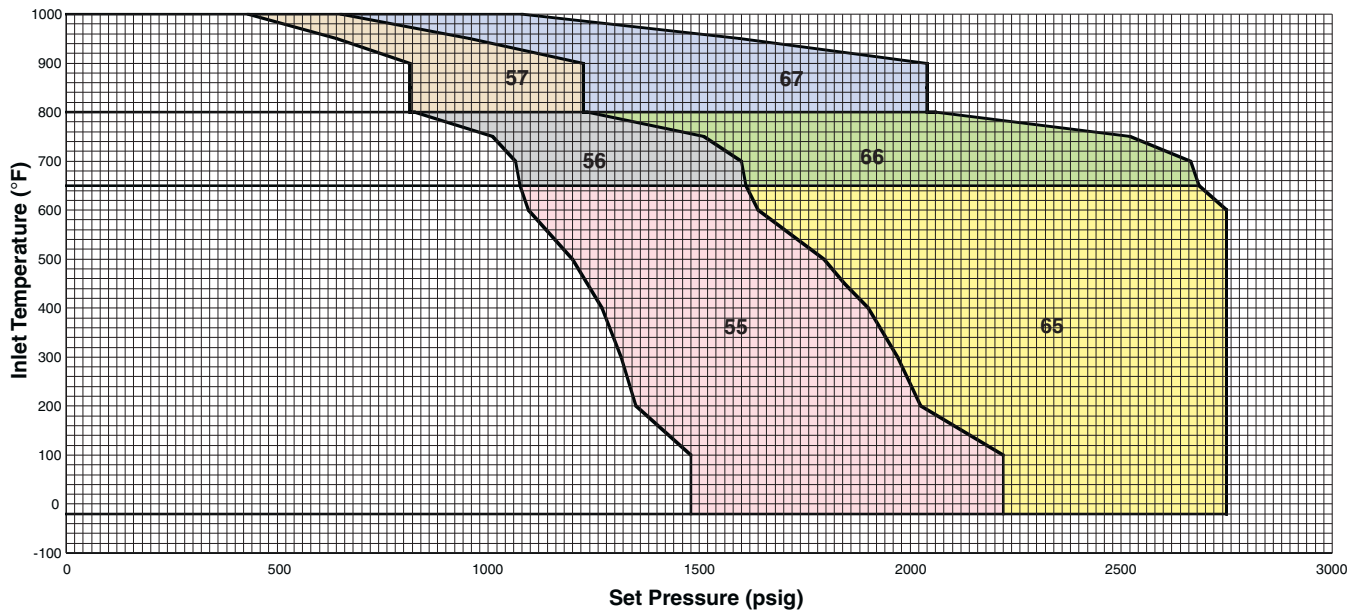

Sizes and Pressure/Temperature Limits

J Orifice, 1.287 sq.in. [830 sq.mm] Effective Area

Valve Series	Valve Size Inlet X Orifice X Outlet	Standard Connections ANSI Flanges Raised Face		Maximum Set Pressure - psig								Back Press. Limit@100°F psig		Maximum Set Pressure - barg						Back Press. Limit@38°C barg	
				Inlet										Inlet							
				-450°F to -75°F	-75°F to -21°F	-20°F to +100°F	+650°F ¹	+800°F	+1000°F	-268°C to -60°C	-59°C to -30°C			-29°C to +38°C	+343°C ¹	+427°C	+538°C				
				Inlet	Outlet											JOS ²	JBS ²				
JOS-E-15	2J3	150	150			285	125					285	230					19.6	15.8		
JBS-E-25	2J3	300	150			285	285					285	230					19.6	15.8		
JLT-E-35	3J4	300	150			740	535					285	230					19.6	15.8		
JOS-H-E-45	3J4	600	150			1480	1075					285	230					19.6	15.8		
JOS-E-55	3J4	900	150			2220	1610					285	230					19.6	15.8		
JBS-E-65	3J4	1500	300			2700	2685					600	230					41.3	15.8		
JOS-E-16	2J3	150	150				125	80				285	230					19.6	15.8		
JBS-E-26	2J3	300	150				285	285				285	230					19.6	15.8		
JLT-E-36	3J4	300	150				535	410				285	230					19.6	15.8		
JOS-H-E-46	3J4	600	150				1075	825				285	230					19.6	15.8		
JOS-E-56	3J4	900	150				1610	1235				285	230					19.6	15.8		
JBS-E-66	3J4	1500	300				2685	2060				600	230					41.3	15.8		
JOS-E-37	3J4	300	150					510	215			285	230					19.6	15.8		
JLT-E-47	3J4	600	150					815	430			285	230					19.6	15.8		
JOS-H-E-57	3J4	900	150					1225	650			285	230					19.6	15.8		
JBS-E-67	3J4	1500	300					2040	1080			600	230					41.3	15.8		
JOS-E-14	2J3	150	150		275							275	230					18.9	15.8		
JBS-E-24	2J3	300	150		275							275	230					18.9	15.8		
JLT-E-34	3J4	300	150		720							275	230					18.9	15.8		
JLT-E-44	3J4	600	150		1440							275	230					18.9	15.8		
JOS-E-12	2J3	150	150	275								275	230	18.9				18.9	15.8		
JBS-E-22	2J3	300	150	275								275	230	18.9				18.9	15.8		
JLT-E-32	3J4	300	150	500								275	230	34.4				18.9	15.8		
JLT-E-42	3J4	600	150	625								275	230	43.1				18.9	15.8		

Notes

- Upper temperature limit of JOS-H-E-15, 25, 35 and 45 valves is +800°F [+427°C].
- Outlet pressure for temperatures above +100°F [+38°C] should not exceed the ANSI flange rating.
- Valves set below 15 psig [1.03 barg] cannot be stamped with the ASME Code Symbol. Only metal seated valves may be set below 15 psig.
- Series Designations: JLT-JOS-E and JLT-JBS-E signify Series JOS-E, JBS-E with liquid trim for liquid and gas service.

Low Set Pressure Limits

JOS-E	5 psig [0.34 barg]
JBS-E	9 psig [0.62 barg]
JLT-JOS-E	15 psig [1.03 barg]
JLT-JBS-E	25 psig [1.72 barg]

Dimensions and Weights

Valve Series	Valve Dimensions, inches [mm]								Approx. Weight lbs (kg) Type J
	Center to Face		Use to find Bolt Length	Approximate Height					
	Inlet	Outlet		Valve (Cap) Type					
	E	F	X	A & G	J & L	C	D		
JOS-E-, JBS-E-, JLT-E-, JOS-H-E-									
12, 14, 15, 16, 22, 24, 25, 26	5 ³ / ₈ [137]	4 ⁷ / ₈ [124]	1 ¹¹ / ₁₆ [43]	20 ³ / ₄ [527]	23 ³ / ₄ [603]	23 ¹ / ₄ [591]	23 ³ / ₄ [603]	66 (30)	
32, 34, 35, 36, 37, 47	7 ¹ / ₄ [184]	7 ¹ / ₈ [181]	2 ¹ / ₄ [54]	24 ⁵ / ₈ [632]	28 ⁵ / ₈ [727]	27 ⁷ / ₈ [703]	28 ⁵ / ₈ [727]	100 (45)	
42, 44, 45, 46	7 ¹ / ₄ [184]	7 ¹ / ₈ [181]	2 ¹ / ₄ [54]	26 ⁷ / ₈ [683]	30 ⁵ / ₈ [773]	29 ⁷ / ₈ [759]	30 ⁵ / ₈ [778]	128 (57)	
57	7 ¹ / ₄ [184]	7 ¹ / ₈ [181]	2 ¹¹ / ₁₆ [68]	26 ⁵ / ₈ [683]	30 ⁵ / ₈ [773]	29 ⁷ / ₈ [759]	30 ⁵ / ₈ [778]	151 (68)	
55, 56, 65, 66, 67	7 ¹ / ₄ [184]	7 ¹ / ₈ [181]	2 ¹¹ / ₁₆ [68]	28 ³ / ₄ [826]	32 ¹ / ₂ [826]	31 ³ / ₄ [806]	32 ¹ / ₂ [826]	155 (70)	

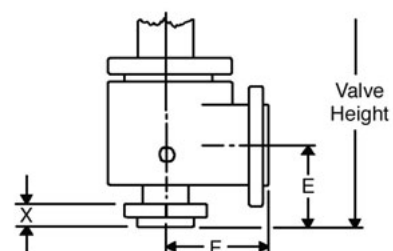

- Type J (Threaded Cap)
- Type C (Regular Lifting Lever) Also JOS-H-E
- Type D (Packed Lifting Lever)
- Type L (Bolted Cap)

Pressure/Temperature Limit Chart - To ANSI Class 600

J Orifice, 1.287 sq.in. [830 sq.mm] Effective Area

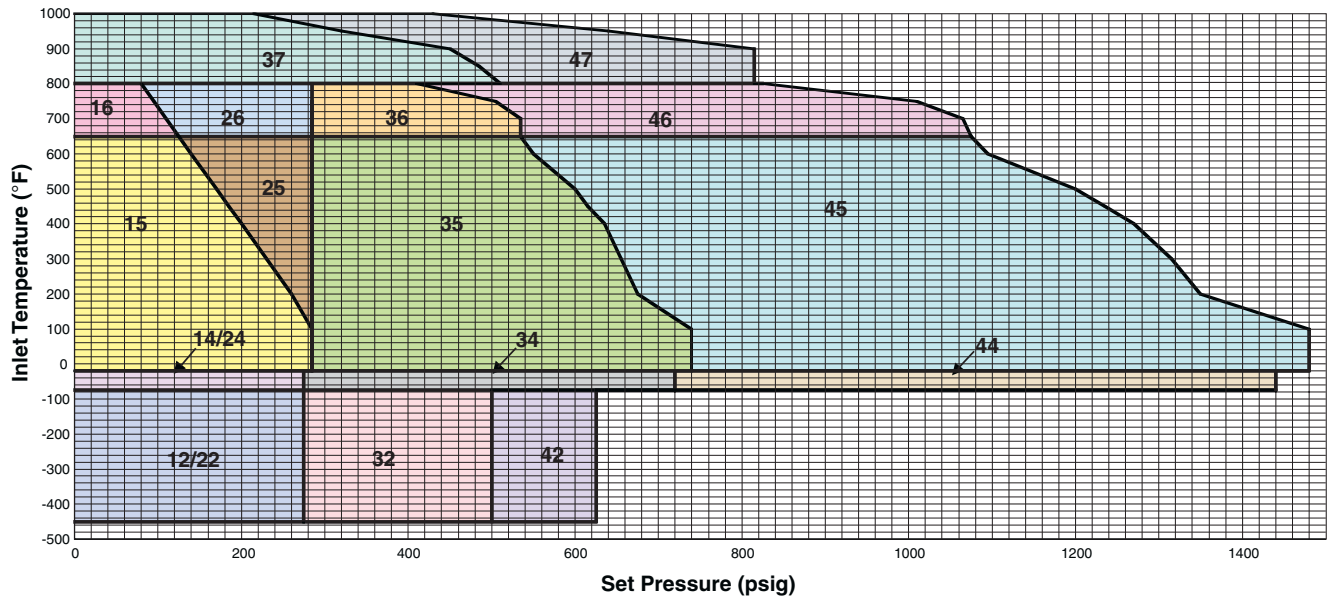

Pressure/Temperature Limit Chart - ANSI Class 900, Class 1500

J Orifice, 1.287 sq.in. [830 sq.mm] Effective Area

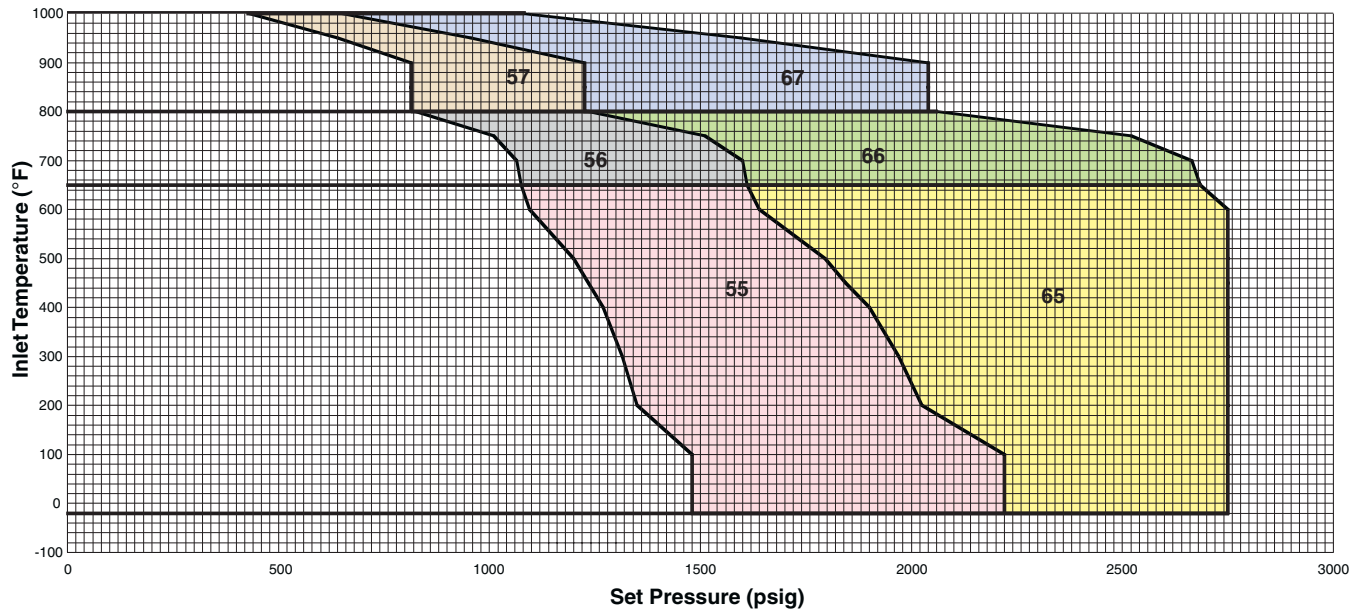

Sizes and Pressure/Temperature Limits

K Orifice, 1.838 sq.in. [1186 sq.mm] Effective Area

Valve Series	Valve Size Inlet X Orifice X Outlet	Standard Connections ANSI Flanges Raised Face		Maximum Set Pressure - psig							Back Press. Limit@100°F psig		Maximum Set Pressure - barg						Back Press. Limit@38°C barg									
				Inlet									Inlet															
				-450°F to -75°F	-75°F to -21°F	-20°F to +100°F	+650°F	+800°F	+1000°F	-268°C to -60°C			-59°C to -30°C	-29°C to +38°C	+343°C	+427°C	+538°C	JOS ²			JBS ²							
											Inlet	Outlet							JOS ²	JBS ²								
JOS-E-15	3K4	150	150			285	125										285	150							19.6	10.3		
JBS-E-25	3K4	300	150			285	285										285	150							19.6	10.3		
JLT-E-35	3K4	300	150			740	535										285	150							19.6	10.3		
JOS-H-E-45	3K4	600	150			1480	1075										285	200							19.6	13.7		
JOS-E-55	3K6	900	150			2220	1610										285	200							19.6	13.7		
JBS-E-65	3K6	1500	300			2220	2220										600	200							41.3	13.7		
JOS-E-16	3K4	150	150				125	80									285	150							8.62	5.51	19.6	10.3
JBS-E-26	3K4	300	150				285	285									285	150							19.6	10.3		
JLT-E-36	3K4	300	150				535	410									285	150							36.8	28.2	19.6	10.3
JOS-H-E-46	3K4	600	150				1075	825									285	200							74.1	56.8	19.6	13.7
JOS-E-56	3K6	900	150				1610	1235									285	200							127	85.1	19.6	13.7
JBS-E-66	3K6	1500	300				2220	2060									600	200							153	142	41.3	13.7
JOS-E-37	3K4	300	150					510	215								285	150							35.1	14.8	19.6	10.3
JLT-E-47	3K4	600	150					815	430								285	200							56.2	29.6	19.6	13.7
JOS-H-E-57	3K4	900	150					1225	650								285	200							84.4	44.8	19.6	13.7
JBS-E-67	3K6	1500	300					2040	1080								600	200							140	74.4	41.3	13.7
JOS-E-14	3K4	150	150		275												275	150							18.9		18.9	10.3
JBS-E-24	3K4	300	150		275												275	150							18.9		18.9	10.3
JLT-E-34	3K4	300	150		720												275	150							49.6		18.9	10.3
JOS-E-44	3K4	600	150		1440												275	200							99.3		18.9	13.7
JOS-E-12	3K4	150	150	275													275	150	18.9								18.9	10.3
JBS-E-22	3K4	300	150	275													275	150	18.9								18.9	10.3
JLT-E-32	3K4	300	150	525													275	150	36.2								18.9	10.3
JOS-E-42	3K4	600	150	600													275	200	41.3								18.9	13.7

Notes

- Upper temperature limit of JOS-H-E-15, 25, 35 and 45 valves is +800°F [+427°C].
- Outlet pressure for temperatures above +100°F [+38°C] should not exceed the ANSI flange rating.
- Valves set below 15 psig [1.03 barg] cannot be stamped with the ASME Code Symbol. Only metal seated valves may be set below 15 psig.
- Series Designations: JLT-JOS-E and JLT-JBS-E signify Series JOS-E, JBS-E with liquid trim for liquid and gas service.

Low Set Pressure Limits

JOS-E	5 psig [0.34 barg]
JBS-E	9 psig [0.62 barg]
JLT-JOS-E	15 psig [1.03 barg]
JLT-JBS-E	25 psig [1.72 barg]

Dimensions and Weights

Valve Series	Valve Dimensions, inches [mm]								Approx. Weight lbs (kg) Type J	
	Center to Face		Use to find Bolt Length	Approximate Height						
	Inlet	Outlet		Valve (Cap) Type						
			E	F	X	A & G	J & L	C		D
JOS-E-, JBS-E-, JLT-E-, JOS-H-E-										
12, 14, 15, 16, 22, 24, 25, 26	6 1/8 [156]	6 3/8 [162]	2 1/8 [54]	26 [661]	29 3/4 [756]	29 [737]	29 3/4 [756]	116 (52)		
32, 34, 35, 36, 37, 47	6 1/8 [156]	6 3/8 [162]	2 1/8 [54]	26 [661]	29 3/4 [756]	29 [737]	29 3/4 [756]	117 (53)		
42, 44, 45, 46	7 1/4 [184]	7 1/8 [181]	2 1/8 [54]	29 1/4 [743]	33 [838]	32 1/2 [826]	33 1/4 [845]	160 (73)		
57	7 1/4 [184]	7 1/8 [181]	2 5/16 [59]	29 1/4 [743]	33 [838]	32 1/2 [826]	33 1/4 [845]	175 (79)		
55, 56	7 13/16 [198]	8 1/2 [216]	2 11/16 [68]	33 1/2 [851]	39 [991]	38 [965]	38 3/4 [984]	185 (84)		
65, 66, 67	7 3/4 [197]	8 1/2 [216]	2 11/16 [68]	33 1/2 [851]	39 [991]	38 [965]	38 3/4 [984]	195 (88)		

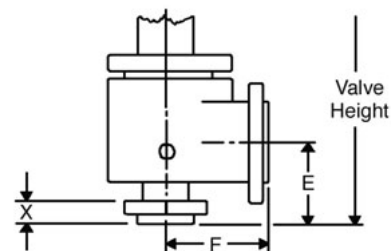

- Type J (Threaded Cap)
- Type C (Regular Lifting Lever) Also JOS-H-E
- Type D (Packed Lifting Lever)
- Type L (Bolted Cap)

Pressure/Temperature Limit Chart - To ANSI Class 600

K Orifice, 1.838 sq.in. [1186 sq.mm] Effective Area

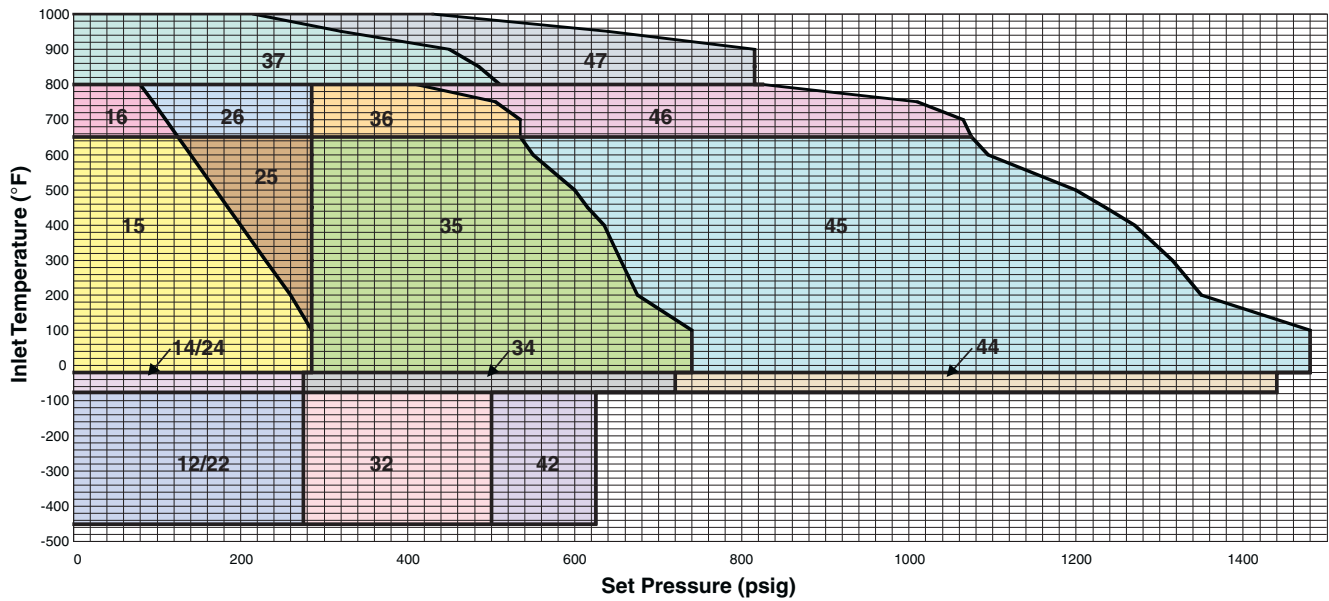

Pressure/Temperature Limit Chart - ANSI Class 900, Class 1500

K Orifice, 1.838 sq.in. [1186 sq.mm] Effective Area

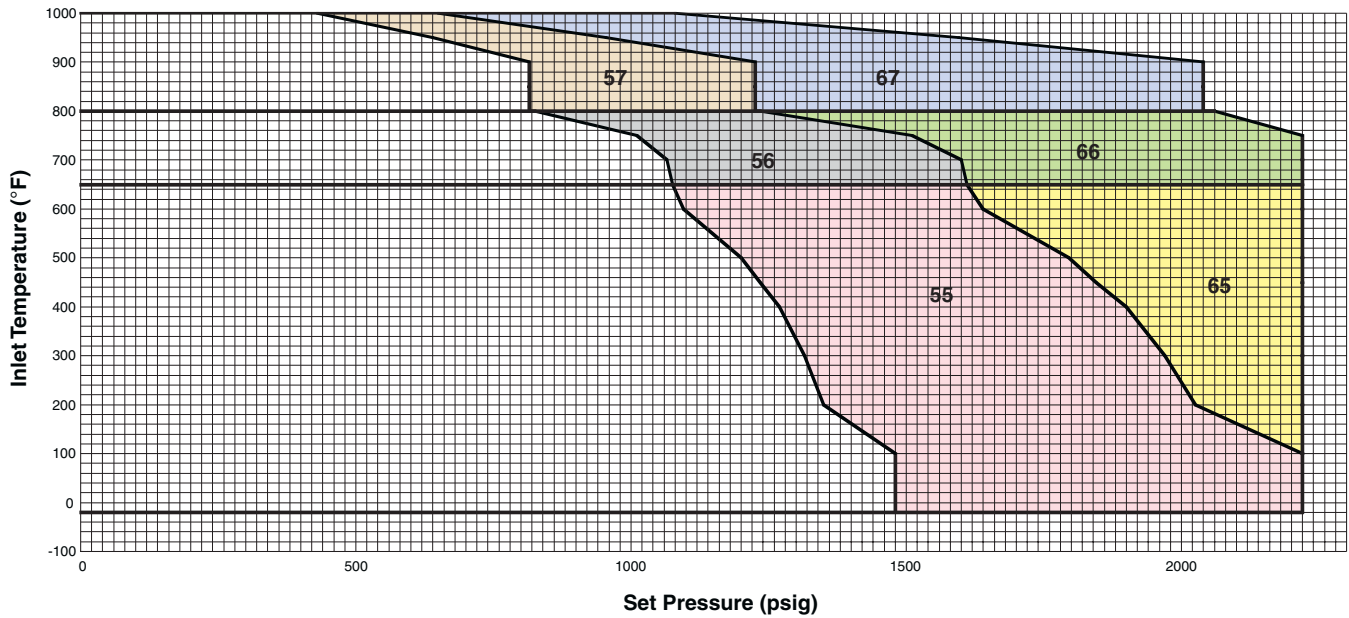

Sizes and Pressure/Temperature Limits

L Orifice, 2.853 sq.in. [1841 sq.mm] Effective Area

Valve Series	Valve Size Inlet X Orifice X Outlet	Standard Connections ANSI Flanges Raised Face		Maximum Set Pressure - psig								Back Press. Limit@100°F psig		Maximum Set Pressure - barg						Back Press. Limit@38°C barg	
				Inlet										Inlet							
				-450°F to -75°F	-75°F to -21°F	-20°F to +100°F	+650°F ¹	+800°F	+1000°F	-268°C to -60°C	-59°C to -30°C			-29°C to +38°C	+343°C ¹	+427°C	+538°C				
				Inlet	Outlet					JOS ²	JBS ²					JOS ²	JBS ²				
JOS-E-15	3L4	150	150			285	125					285	100			19.6	8.62			19.6	6.89
JBS-E-25	3L4	300	150			285	285					285	100			19.6	19.6			19.6	6.89
JLT-E-35	4L6	300	150			740	535					285	170			51.0	36.8			19.6	11.7
JOS-H-E-45	4L6	600	150			1000	1000					285	170			68.9	68.9			19.6	11.7
JOS-E-55	4L6	900	150			1500	1500					285	170			103	103			19.6	11.7
JOS-E-16	3L4	150	150				125	80				285	100			8.62	5.51			19.6	6.89
JBS-E-26	3L4	300	150				285	285				285	100			19.6	19.6			19.6	6.89
JLT-E-36	4L6	300	150				535	410				285	170			36.8	28.2			19.6	11.7
JOS-H-E-46	4L6	600	150				1000	825				285	170			68.9	56.8			19.6	11.7
JOS-E-56	4L6	900	150				1500	1235				285	170			103	85.1			19.6	11.7
JBS-E-66	4L6	1500	150				1500	1500				285	170			103	103			41.3	11.7
JOS-E-37	4L6	300	150					510	215			285	170					35.1	14.8	19.6	11.7
JLT-E-47	4L6	600	150					1000	430			285	170					68.9	29.6	19.6	11.7
JOS-H-E-57	4L6	900	150					1500	650			285	170					103	44.8	19.6	11.7
JBS-E-67	4L6	1500	150					1500	1080			285	170					103	74.4	41.3	11.7
JOS-E-14	3L4	150	150		275							275	100							18.9	6.89
JBS-E-24	3L4	300	150		275							275	100							18.9	6.89
JBS-E-34	4L6	300	150		720							275	170							18.9	11.7
JLT-E-44	4L6	600	150		1000							275	170							18.9	11.7
JOS-E-12	3L4	150	150	275								275	100	18.9						18.9	6.89
JBS-E-22	3L4	300	150	275								275	100	18.9						18.9	6.89
JBS-E-32	4L6	300	150	535								275	170	36.8						18.9	11.7
JLT-E-42	4L6	600	150	535								275	170	36.8						18.9	11.7

Notes

- Upper temperature limit of JOS-H-E-15, 25, 35 and 45 valves is +800°F [+427°C].
- Outlet pressure for temperatures above +100°F [+38°C] should not exceed the ANSI flange rating.
- Valves set below 15 psig [1.03 barg] cannot be stamped with the ASME Code Symbol. Only metal seated valves may be set below 15 psig.
- Series Designations: JLT-JOS-E and JLT-JBS-E signify Series JOS-E, JBS-E with liquid trim for liquid and gas service.

Low Set Pressure Limits

JOS-E	6 psig [0.41 barg]
JBS-E	8 psig [0.55 barg]
JLT-JOS-E	15 psig [1.03 barg]
JLT-JBS-E	25 psig [1.72 barg]

Dimensions and Weights

Valve Series	Valve Dimensions, inches [mm]								Approx. Weight lbs (kg) Type J
	Center to Face		Use to find Bolt Length	Approximate Height					
	Inlet	Outlet		Valve (Cap) Type					
	E	F	X	A & G	J & L	C	D		
JOS-E-, JBS-E-, JLT-E-, JOS-H-E-									
12, 14, 15, 16, 22, 24, 25, 26	6 ¹ / ₈ [156]	6 ¹ / ₂ [165]	2 [51]	30 ¹ / ₄ [769]	34 [864]	33 ¹ / ₄ [845]	34 [864]	152 (69)	
32, 34, 35, 36, 37	7 ¹ / ₁₆ [179]	7 ¹ / ₈ [181]	2 ¹ / ₈ [54]	30 ¹ / ₄ [769]	34 [864]	34 ¹ / ₄ [870]	34 ¹ / ₄ [870]	192 (87)	
42, 44, 45, 46, 47	7 ¹ / ₁₆ [179]	8 [203]	2 ³ / ₈ [60]	31 ¹ / ₂ [801]	35 ¹ / ₄ [895]	34 ³ / ₄ [883]	35 ¹ / ₄ [895]	226 (103)	
55, 56, 57, 66, 67	7 ³ / ₄ [197]	8 ³ / ₄ [222]	2 ¹⁵ / ₁₆ [75]	34 ¹ / ₄ [871]	39 ³ / ₄ [1010]	38 ³ / ₄ [984]	39 ¹ / ₂ [1003]	270 (122)	

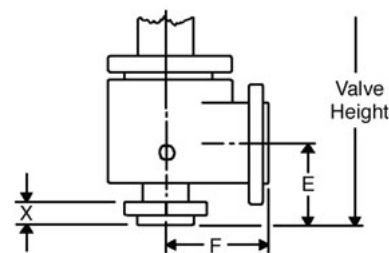

- Type J (Threaded Cap)
- Type C (Regular Lifting Lever) Also JOS-H-E
- Type D (Packed Lifting Lever)
- Type L (Bolted Cap)

Pressure/Temperature Limit Chart

L Orifice, 2.853 sq.in. [1841 sq.mm] Effective Area

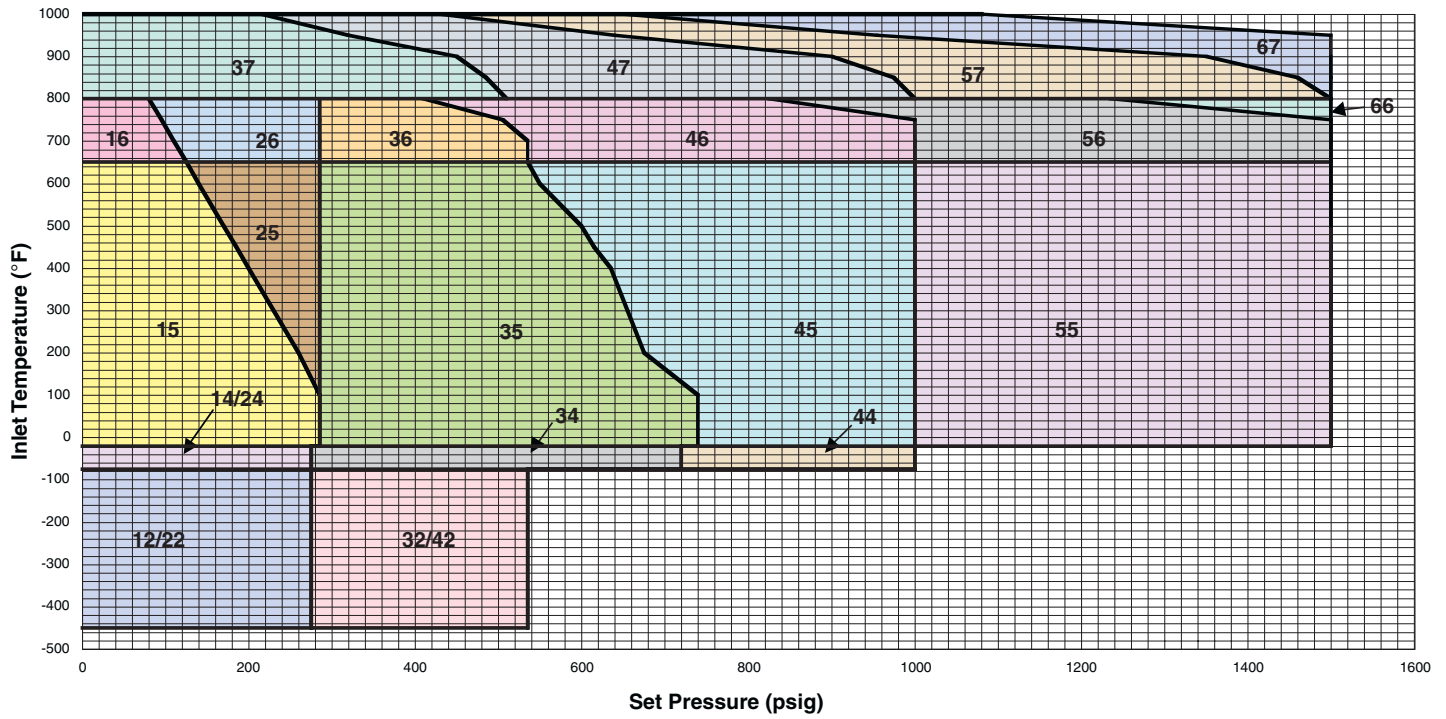

Sizes and Pressure/Temperature Limits

M Orifice, 3.60 sq.in. [2323 sq.mm] Effective Area

Valve Series	Valve Size Inlet X Orifice X Outlet	Standard Connections ANSI Flanges Raised Face		Maximum Set Pressure - psig							Back Press. Limit@100°F psig		Maximum Set Pressure - barg						Back Press. Limit@38°C barg	
				Inlet									Inlet							
				-450°F to -75°F	-75°F to -21°F	-20°F to +100°F	+650°F ¹	+800°F	+1000°F	-268°C to -60°C			-59°C to -30°C	-29°C to +38°C	+343°C ¹	+427°C	+538°C	JOS ²		
											Inlet	Outlet							JOS ²	JBS ²
JOS-E-15	4M6	150	150			285	125							19.6	8.62			19.6	5.51	
JBS-E-25	4M6	300	150			285	285							19.6	19.6			19.6	5.51	
JLT-E-35	4M6	300	150			740	535							51.0	36.8			19.6	11.0	
JOS-H-E-45	4M6	600	150			1100	1075							75.8	74.1			19.6	11.0	
JOS-E-16	4M6	150	150				125	80							8.62	5.51			19.6	5.51
JBS-E-26	4M6	300	150				285	285							19.6	19.6			19.6	5.51
JLT-E-36	4M6	300	150				535	410							36.8	28.2			19.6	11.0
JOS-H-E-46	4M6	600	150				1075	825							74.1	56.8			19.6	11.0
JOS-E-56	4M6	900	150				1100	1100							75.8	75.8			19.6	11.0
JOS-E-37	4M6	300	150					510	215								35.1	14.8	19.6	11.0
JLT-E-47	4M6	600	150					1015	430								70	29.6	19.6	11.0
JOS-H-E-57	4M6	900	150					1100	650								75.8	44.8	19.6	11.0
JOS-E-14	4M6	150	150		275								18.9						18.9	5.51
JBS-E-24	4M6	300	150		275								18.9						18.9	5.51
JLT-E-34	4M6	300	150		720								49.6						18.9	11.0
JOS-H-E-44	4M6	600	150		1100								75.8						18.9	11.0
JOS-E-12	4M6	150	150	275								18.9							18.9	5.51
JBS-E-22	4M6	300	150	275								18.9							18.9	5.51
JLT-E-32	4M6	300	150	525								36.2							18.9	11.0
JOS-H-E-42	4M6	600	150	600								41.3							18.9	11.0

Notes

- Upper temperature limit of JOS-H-E-15, 25, 35 and 45 valves is +800°F [+427°C].
- Outlet pressure for temperatures above +100°F [+38°C] should not exceed the ANSI flange rating.
- Valves set below 15 psig [1.03 barg] cannot be stamped with the ASME Code Symbol. Only metal seated valves may be set below 15 psig.
- Series Designations: JLT-JOS-E and JLT-JBS-E signify Series JOS-E, JBS-E with liquid trim for liquid and gas service.

Low Set Pressure Limits

JOS-E	8 psig [0.55 barg]
JBS-E	10 psig [0.68 barg]
JLT-JOS-E	15 psig [1.03 barg]
JLT-JBS-E	25 psig [1.72 barg]

Dimensions and Weights

Valve Series	Valve Dimensions, inches [mm]								Approx. Weight lbs (kg) Type J
	Center to Face		Use to find Bolt Length	Approximate Height					
	Inlet	Outlet		Valve (Cap) Type					
	E	F	X	A & G	J & L	C	D		
JOS-E-, JBS-E-, JLT-E-, JOS-H-E-									
12, 14, 15, 16, 22, 24, 25, 26	7 [178]	7 1/4 [184]	2 1/8 [54]	29 3/4 [756]	33 1/2 [851]	33 [838]	33 3/4 [857]	201 (91)	
32, 34, 35, 36, 37	7 [178]	7 1/4 [184]	2 1/8 [54]	32 1/4 [820]	36 [914]	35 1/2 [902]	36 [914]	222 (101)	
42, 44, 45, 46, 47	7 [178]	8 [203]	2 7/16 [62]	36 1/2 [925]	42 [1067]	41 [1041]	41 3/4 [1060]	265 (120)	
56, 57	7 3/4 [197]	8 3/4 [222]	2 9/16 [65]	37 1/4 [947]	42 3/4 [1086]	41 3/4 [1060]	42 1/2 [1080]	290 (132)	

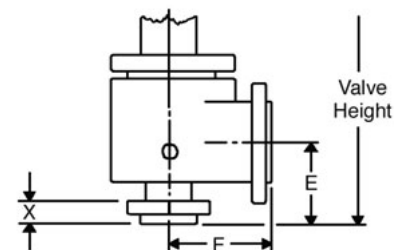

- Type J (Threaded Cap)
- Type C (Regular Lifting Lever) Also JOS-H-E
- Type D (Packed Lifting Lever)
- Type L (Bolted Cap)

Pressure/Temperature Limit Chart
M Orifice, 3.60 sq.in. [2323 sq.mm] Effective Area

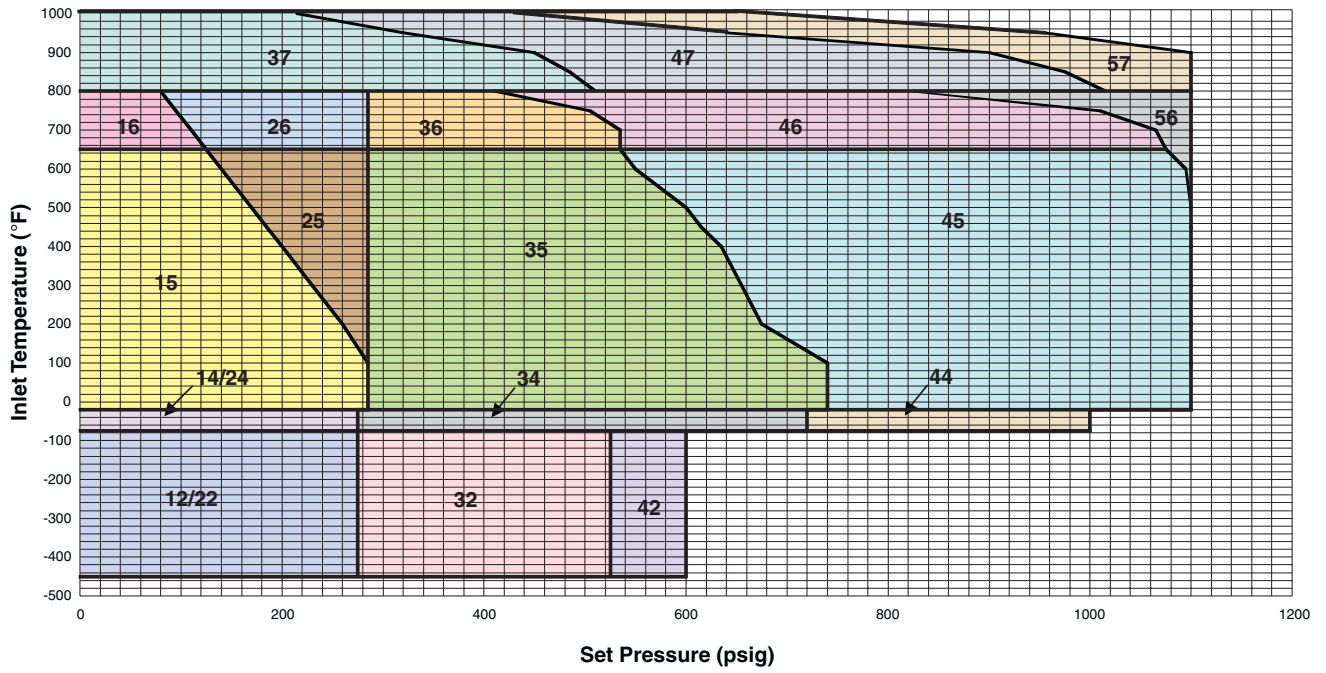

Sizes and Pressure/Temperature Limits

N Orifice, 4.34 sq.in. [2800 sq.mm] Effective Area

Valve Series	Valve Size Inlet X Orifice X Outlet		Standard Connections ANSI Flanges Raised Face		Maximum Set Pressure - psig						Back Press. Limit@100°F psig		Maximum Set Pressure - barg						Back Press. Limit@38°C barg	
					Inlet								Inlet							
					-450°F to -75°F	-75°F to -21°F	-20°F to +100°F	+650°F ¹	+800°F	+1000°F			-268°C to -60°C	-59°C to -30°C	-29°C to +38°C	+343°C ¹	+427°C	+538°C		
					Inlet	Outlet														
JOS-E-15	4N6	150	150			285	125				285	80			19.6	8.62			19.6	5.51
JBS-E-25	4N6	300	150			285	285				285	80			19.6	19.6			19.6	5.51
JLT-E-35	4N6	300	150			740	535				285	160			51.0	36.8			19.6	11.0
JOS-H-E-45	4N6	600	150			1000	1000				285	160			68.9	68.9			19.6	11.0
JOS-E-16	4N6	150	150				125	80			285	80			8.62	5.51			19.6	5.51
JBS-E-26	4N6	300	150				285	285			285	80			19.6	19.6			19.6	5.51
JLT-E-36	4N6	300	150				535	410			285	160			36.8	28.2			19.6	11.0
JOS-H-E-46	4N6	600	150				1000	825			285	160			68.9	56.8			19.6	11.0
JOS-E-37	4N6	300	150					510	215		285	160					35.1	14.8	19.6	11.0
JLT-E-47	4N6	600	150					1000	430		285	160					68.9	29.6	19.6	11.0
JOS-H-E-																				
JOS-E-14	4N6	150	150		275						275	80		18.9					18.9	5.51
JBS-E-24	4N6	300	150		275						275	80		18.9					18.9	5.51
JLT-E-34	4N6	300	150		720						275	160		49.6					18.9	11.0
JLT-E-44	4N6	600	150		1000						275	160		68.9					18.9	11.0
JOS-E-12	4N6	150	150	275							275	80	18.9						18.9	5.51
JBS-E-22	4N6	300	150	275							275	80	18.9						18.9	5.51
JLT-E-32	4N6	300	150	450							275	160	31.0						18.9	11.0
JLT-E-42	4N6	600	150	500							275	160	34.4						18.9	11.0

Notes

- Upper temperature limit of JOS-H-E-15, 25, 35 and 45 valves is +800°F [+427°C].
- Outlet pressure for temperatures above +100°F [+38°C] should not exceed the ANSI flange rating.
- Valves set below 15 psig [1.03 barg] cannot be stamped with the ASME Code Symbol. Only metal seated valves may be set below 15 psig.
- Series Designations: JLT-JOS-E and JLT-JBS-E signify Series JOS-E, JBS-E with liquid trim for liquid and gas service.

Low Set Pressure Limits

JOS-E	8 psig [0.55 barg]
JBS-E	10 psig [0.68 barg]
JLT-JOS-E	15 psig [1.03 barg]
JLT-JBS-E	25 psig [1.72 barg]

Dimensions and Weights

Valve Series	Valve Dimensions, inches [mm]								Approx. Weight lbs (kg) Type J
	Center to Face		Use to find Bolt Length	Approximate Height					
	Inlet	Outlet		Valve (Cap) Type					
	E	F	X	A & G	J & L	C	D		
JOS-E-, JBS-E-, JLT-E-, JOS-H-E-									
12, 14, 15, 16, 22, 24, 25, 26	7 ³ / ₄ [197]	8 ¹ / ₄ [210]	2 ¹ / ₈ [54]	37 ³ / ₄ [959]	43 ¹ / ₄ [1099]	42 ¹ / ₄ [1073]	43 [1092]	260 (118)	
32, 34, 35, 36, 37	7 ³ / ₄ [197]	8 ¹ / ₄ [210]	2 ¹ / ₈ [54]	37 ³ / ₄ [959]	43 ¹ / ₄ [1099]	42 ¹ / ₄ [1073]	43 [1092]	280 (127)	
42, 44, 45, 46, 47	7 ³ / ₄ [197]	8 ³ / ₄ [222]	2 ³ / ₈ [60]	37 ³ / ₄ [959]	43 ¹ / ₄ [1099]	42 ¹ / ₄ [1073]	43 [1092]	297 (135)	

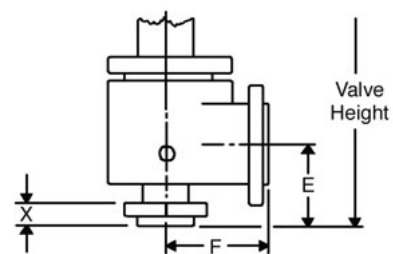

- Type J (Threaded Cap)
- Type C (Regular Lifting Lever) Also JOS-H-E
- Type D (Packed Lifting Lever)
- Type L (Bolted Cap)

Pressure/Temperature Limit Chart
N Orifice, 4.34 sq.in. [2800 sq.mm] Effective Area

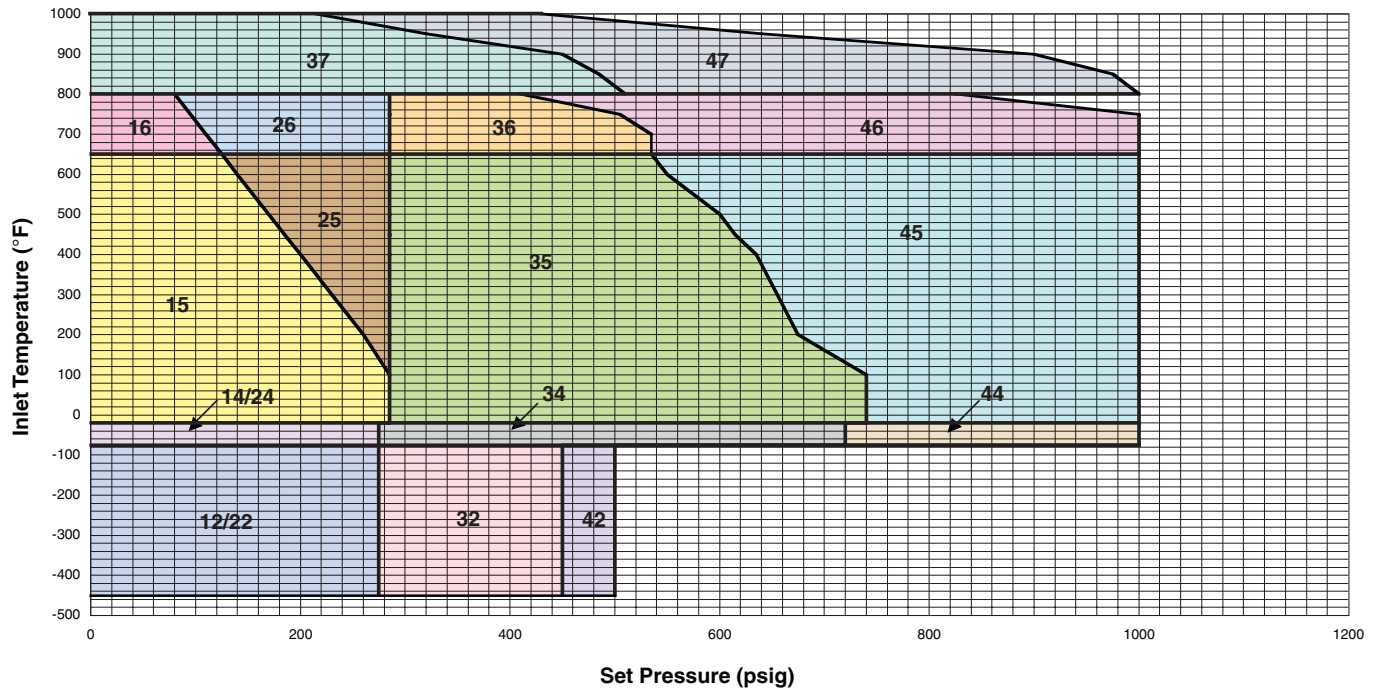

Sizes and Pressure/Temperature Limits

P Orifice, 6.38 sq.in. [4116 sq.mm] Effective Area

Valve Series	Valve Size Inlet X Orifice X Outlet		Standard Connections ANSI Flanges Raised Face		Maximum Set Pressure - psig						Back Press. Limit@100°F psig		Maximum Set Pressure - barg						Back Press. Limit@38°C barg				
					Inlet								Inlet										
					-450°F to -75°F	-75°F to -21°F	-20°F to +100°F	+650°F ¹	+800°F	+1000°F			-268°C to -60°C	-59°C to -30°C	-29°C to +38°C	+343°C ¹	+427°C	+538°C					
					JOS ²	JBS ²	JOS ²	JBS ²	JOS ²	JBS ²	JOS ²	JBS ²											
JOS-E-15	15	4P6	150	150			285	125			285	80					19.6	8.62			19.6	5.51	
JBS-E-25	25	4P6	300	150			285	285			285	80					19.6	19.6			19.6	5.51	
JLT-E-35	35	4P6	300	150			525	525			285	150					36.2	36.2			19.6	10.3	
JOS-H-E-45	45	4P6	600	150			1000	1000			285	150					68.9	68.9			19.6	10.3	
JOS-E-16	16	4P6	150	150				125	80		285	80						8.62	5.51			19.6	5.51
JBS-E-26	26	4P6	300	150				285	285		285	80						19.6	19.6			19.6	5.51
JLT-E-36	36	4P6	300	150				525	410		285	150						36.2	28.2			19.6	10.3
JOS-H-E-46	46	4P6	600	150				1000	825		285	150						68.9	56.8			19.6	10.3
JOS-E-37	37	4P6	300	150					510	215	285	150								35.1	14.8	19.6	10.3
JLT-E-47	47	4P6	600	150					1000	430	285	150								68.9	29.6	19.6	10.3
JOS-H-E-	JOS-H-E-																						
JOS-E-14	14	4P6	150	150		275					275	80		18.9								18.9	5.51
JBS-E-24	24	4P6	300	150		275					275	80		18.9								18.9	5.51
JLT-E-34	34	4P6	300	150		525					275	150		36.2								18.9	10.3
JLT-E-44	44	4P6	600	150		1000					275	150		68.9								18.9	10.3
JOS-E-12	12	4P6	150	150	175						275	80	12.0									18.9	5.51
JBS-E-22	22	4P6	300	150	175						275	80	12.0									18.9	5.51
JLT-E-32	32	4P6	300	150	300						275	150	20.6									18.9	10.3
JLT-E-42	42	4P6	600	150	480						275	150	33.1									18.9	10.3

Notes

- Upper temperature limit of JOS-H-E-15, 25, 35 and 45 valves is +800°F [+427°C].
- Outlet pressure for temperatures above +100°F [+38°C] should not exceed the ANSI flange rating.
- Valves set below 15 psig [1.03 barg] cannot be stamped with the ASME Code Symbol. Only metal seated valves may be set below 15 psig.
- Series Designations: JLT-JOS-E and JLT-JBS-E signify Series JOS-E, JBS-E with liquid trim for liquid and gas service.

Low Set Pressure Limits

JOS-E	7 psig [0.48 barg]
JBS-E	8 psig [0.55 barg]
JLT-JOS-E	15 psig [1.03 barg]
JLT-JBS-E	25 psig [1.72 barg]

Dimensions and Weights

Valve Series	Valve Dimensions, inches [mm]							Approx. Weight lbs (kg) Type J
	Center to Face		Use to find Bolt Length	Approximate Height				
	Inlet	Outlet		Valve (Cap) Type				
	E	F	X	A & G	J & L	C	D	
JOS-E-, JBS-E-, JLT-E-, JOS-H-E-								
12, 14, 15, 16, 22, 24, 25, 26	7 ¹ / ₈ [181]	9 [229]	2 ¹ / ₈ [54]	37 [940]	42 ¹ / ₂ [1080]	41 ¹ / ₂ [1054]	42 ¹ / ₄ [1073]	270 (122)
32, 34, 35, 36, 37	8 ⁷ / ₈ [225]	10 [254]	2 ¹ / ₈ [54]	38 ³ / ₄ [984]	44 ¹ / ₄ [1124]	43 ¹ / ₄ [1099]	44 [1118]	286 (130)
42, 44, 45, 46, 47	8 ⁷ / ₈ [225]	10 [254]	2 ⁹ / ₁₆ [65]	41 [1041]	46 ¹ / ₂ [1181]	45 ¹ / ₂ [1156]	46 ¹ / ₄ [1175]	401 (182)

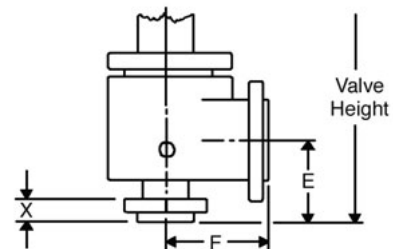

- Type J (Threaded Cap)
- Type C (Regular Lifting Lever) Also JOS-H-E
- Type D (Packed Lifting Lever)
- Type L (Bolted Cap)

Pressure/Temperature Limit Chart
P Orifice, 6.38 sq.in. [4116 sq.mm] Effective Area

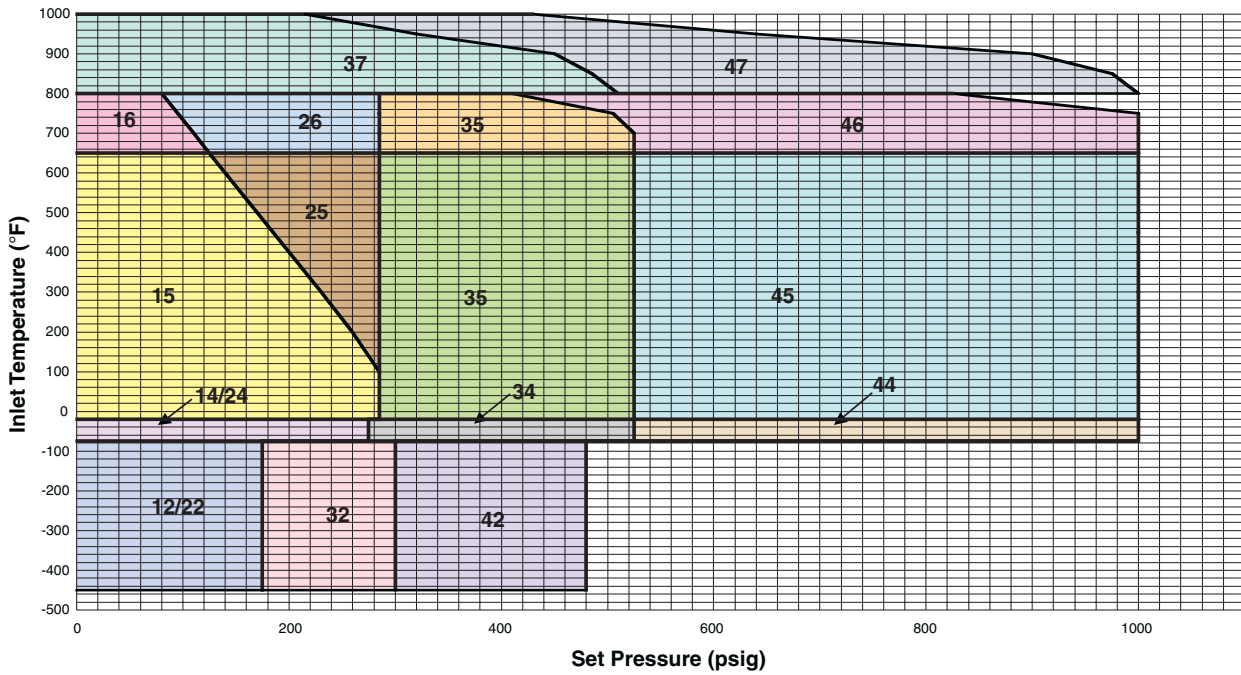

Sizes and Pressure/Temperature Limits

Q Orifice, 11.05 sq.in. [7129 sq.mm] Effective Area

Valve Series	Valve Size Inlet X Orifice X Outlet		Standard Connections ANSI Flanges Raised Face		Maximum Set Pressure - psig						Back Press. Limit@100°F psig		Maximum Set Pressure - barg						Back Press. Limit@38°C barg			
					Inlet								Inlet									
					-450°F to -75°F	-75°F to -21°F	-20°F to +100°F	+650°F ¹	+800°F	+1000°F			-268°C to -60°C	-59°C to -30°C	-29°C to +38°C	+343°C ¹	+427°C	+538°C			JOS ²	JBS ²
JOS-E-15	6Q8	150	150			165	125				115	70				11.3	8.62			7.92	4.82	
JBS-E-25	6Q8	300	150			165	165				115	70				11.3	11.3			7.92	4.82	
JLT-E-35	6Q8	300	150			300	300				115	115				20.6	20.6			7.92	7.92	
JOS-H-E-45	6Q8	600	150			600	600				115	115				41.3	41.3			7.92	7.92	
JOS-E-16	6Q8	150	150				125	80			115	70					8.62	5.51			7.92	4.82
JBS-E-26	6Q8	300	150				165	165			115	70					11.3	11.3			7.92	4.82
JLT-E-36	6Q8	300	150				300	300			115	115					20.6	20.6			7.92	7.92
JOS-H-E-46	6Q8	600	150				600	600			115	115					41.3	41.3			7.92	7.92
JOS-E-37	6Q8	300	150					165	165		115	115							11.3	11.3	7.92	7.92
JLT-E-47	6Q8	600	150					600	430		115	115							41.3	29.6	7.92	7.92
JOS-H-E-																						
JOS-E-14	6Q8	150	150		165						115	70		11.3							7.92	4.82
JBS-E-24	6Q8	300	150		165						115	70		11.3							7.92	4.82
JLT-E-34	6Q8	300	150		300						115	115		20.6							7.92	7.92
JLT-E-44	6Q8	600	150		600						115	115		41.3							7.92	7.92
JOS-E-12	6Q8	150	150	165							115	70	11.3								7.92	4.82
JBS-E-22	6Q8	300	150	165							115	70	11.3								7.92	4.82
JLT-E-32	6Q8	300	150	250							115	115	17.2								7.92	7.92
JLT-E-42	6Q8	600	150	300							115	115	20.6								7.92	7.92

Notes

- Upper temperature limit of JOS-H-E-15, 25, 35 and 45 valves is +800°F [+427°C].
- Outlet pressure for temperatures above +100°F [+38°C] should not exceed the ANSI flange rating.
- Valves set below 15 psig [1.03 barg] cannot be stamped with the ASME Code Symbol. Only metal seated valves may be set below 15 psig.
- Series Designations: JLT-JOS-E and JLT-JBS-E signify Series JOS-E, JBS-E with liquid trim for liquid and gas service.

Low Set Pressure Limits

JOS-E	7 psig [0.48 barg]
JBS-E	8 psig [0.55 barg]
JLT-JOS-E	15 psig [1.03 barg]
JLT-JBS-E	25 psig [1.72 barg]

Dimensions and Weights

Valve Series	Valve Dimensions, inches [mm]								Approx. Weight lbs (kg) Type J
	Center to Face		Use to find Bolt Length	Approximate Height					
	Inlet	Outlet		Valve (Cap) Type					
	E	F	X	A & G	J & L	C	D		
JOS-E-, JBS-E-, JLT-E-, JOS-H-E-									
12, 14, 15, 16, 22, 24, 25, 26	97/16 [240]	9 1/2 [241]	2 5/16 [59]	42 1/4 [1073]	47 3/4 [1213]	46 3/4 [1187]	47 1/2 [1207]	481 (218)	
32, 34, 35, 36, 37	97/16 [240]	9 1/2 [241]	2 5/16 [59]	42 1/4 [1073]	47 3/4 [1213]	46 3/4 [1187]	47 1/2 [1207]	492 (223)	
42, 44, 45, 46, 47	97/16 [240]	9 1/2 [241]	2 15/16 [75]	46 1/4 [1175]	51 3/4 [1314]	50 3/4 [1289]	51 1/2 [1308]	565 (256)	

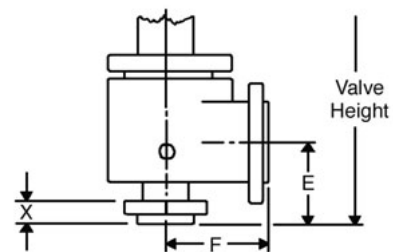

- Type J (Threaded Cap)
- Type C (Regular Lifting Lever) Also JOS-H-E
- Type D (Packed Lifting Lever)
- Type L (Bolted Cap)

Pressure/Temperature Limit Chart

Q Orifice, 11.05 sq.in. [7129 sq.mm] Effective Area

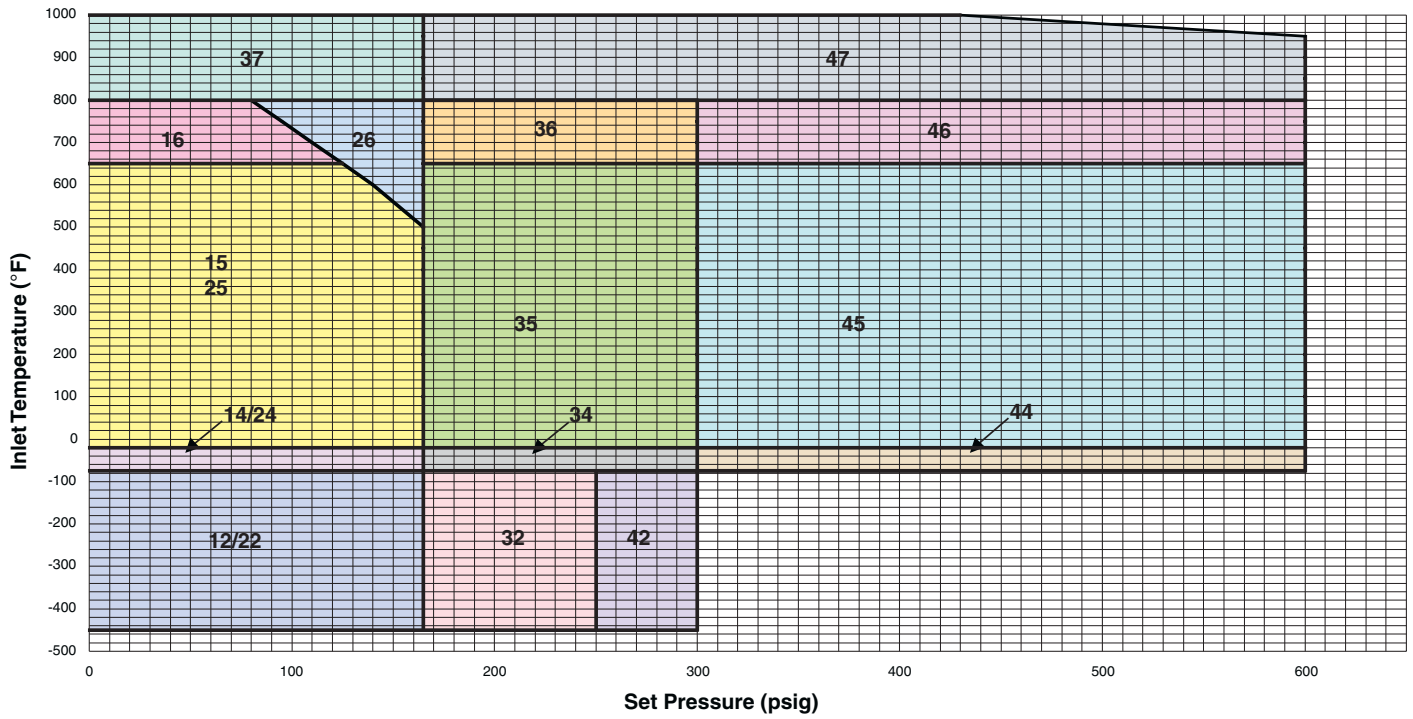

Sizes and Pressure/Temperature Limits

R Orifice, 16.0 sq.in. [10,323 sq.mm] Effective Area

Valve Series	Valve Size Inlet X Orifice X Outlet		Standard Connections ANSI Flanges Raised Face		Maximum Set Pressure - psig						Back Press. Limit@100°F psig		Maximum Set Pressure - barg						Back Press. Limit@38°C barg		
					Inlet								Inlet								
					-450°F to -75°F	-75°F to -21°F	-20°F to +100°F	+650°F	+800°F	+1000°F			-268°C to -60°C	-59°C to -30°C	-29°C to +38°C	+343°C	+427°C	+538°C			
					Inlet	Outlet	JOS ²	JBS ²	JOS ²	JBS ²	JOS ²	JBS ²									
JOS-E-	15	6R8	150	150			100	100			60	60			6.89	6.89			4.13	4.13	
JBS-E-	25	6R8	300	150			100	100			60	60			6.89	6.89			4.13	4.13	
JLT-E-	35	6R10	300	150			230	230			100	100			15.8	15.8			6.89	6.89	
JOS-H-E-	45	6R10	600	150			300	300			100	100			20.6	20.6			6.89	6.89	
JOS-E-	16	6R8	150	150				100	80		60	60				6.89	5.51			4.13	4.13
JBS-E-	26	6R8	300	150				100	100		60	60				6.89	6.89			4.13	4.13
JLT-E-	36	6R10	300	150				230	230		100	100				15.8	15.8			6.89	6.89
JOS-H-E-	46	6R10	600	150				300	300		100	100				20.6	20.6			6.89	6.89
JOS-E-	37	6R8	300	150					100	100	60	60						6.89	6.89	4.13	4.13
JLT-E-	47	6R10	600	150					300	300	100	100						20.6	20.6	6.89	6.89
JOS-H-E-																					
JOS-E-	14	6R8	150	150		100					60	60		6.89						4.13	4.13
JBS-E-	24	6R8	300	150		100					60	60		6.89						4.13	4.13
JLT-E-	34	6R10	300	150		230					100	100		15.8						6.89	6.89
JOS-H-E-	44	6R10	600	150		300					100	100		20.6						6.89	6.89
JOS-E-	12	6R8	150	150	55						60	60	3.79							4.13	4.13
JBS-E-	22	6R8	300	150	55						60	60	3.79							4.13	4.13
JLT-E-	32	6R10	300	150	150						100	100	10.3							6.89	6.89
JOS-H-E-	42	6R10	600	150	200						100	100	13.7							6.89	6.89

Notes

- Upper temperature limit of JOS-H-E-15, 25, 35 and 45 valves is +800°F [+427°C].
- Outlet pressure for temperatures above +100°F [+38°C] should not exceed the ANSI flange rating.
- Valves set below 15 psig [1.03 barg] cannot be stamped with the ASME Code Symbol. Only metal seated valves may be set below 15 psig.
- Series Designations: JLT-JOS-E and JLT-JBS-E signify Series JOS-E, JBS-E with liquid trim for liquid and gas service.

Low Set Pressure Limits

JOS-E	8 psig [0.55 barg]
JBS-E	8 psig [0.55 barg]
JLT-JOS-E	15 psig [1.03 barg]
JLT-JBS-E	25 psig [1.72 barg]

Dimensions and Weights

Valve Series	Valve Dimensions, inches [mm]								Approx. Weight lbs (kg) Type J
	Center to Face		Use to find Bolt Length	Approximate Height					
	Inlet	Outlet		Valve (Cap) Type					
	E	F	X	A & G	J & L	C	D		
JOS-E-, JBS-E-, JLT-E-, JOS-H-E-									
12, 14, 15, 16, 22, 24, 25, 26	97/16 [240]	9 1/2 [241]	25/16 [59]	47 3/4 [1213]	53 1/4 [1353]	52 1/2 [1334]	53 1/4 [1353]	564 (256)	
32, 34, 35, 36, 37	97/16 [240]	10 1/2 [267]	25/16 [59]	47 3/4 [1213]	53 1/4 [1353]	52 1/2 [1334]	53 1/4 [1353]	602 (273)	
42, 44, 45, 46, 47	97/16 [240]	10 1/2 [267]	2 3/4 [70]	47 3/4 [1213]	53 1/4 [1353]	52 1/2 [1334]	53 1/4 [1353]	631 (286)	

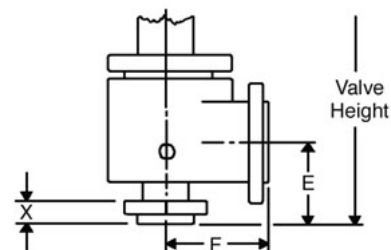

- Type J (Threaded Cap)
- Type C (Regular Lifting Lever) Also JOS-H-E
- Type D (Packed Lifting Lever)
- Type L (Bolted Cap)

Pressure/Temperature Limit Chart
R Orifice, 16.0 sq.in. [10,323 sq.mm] Effective Area

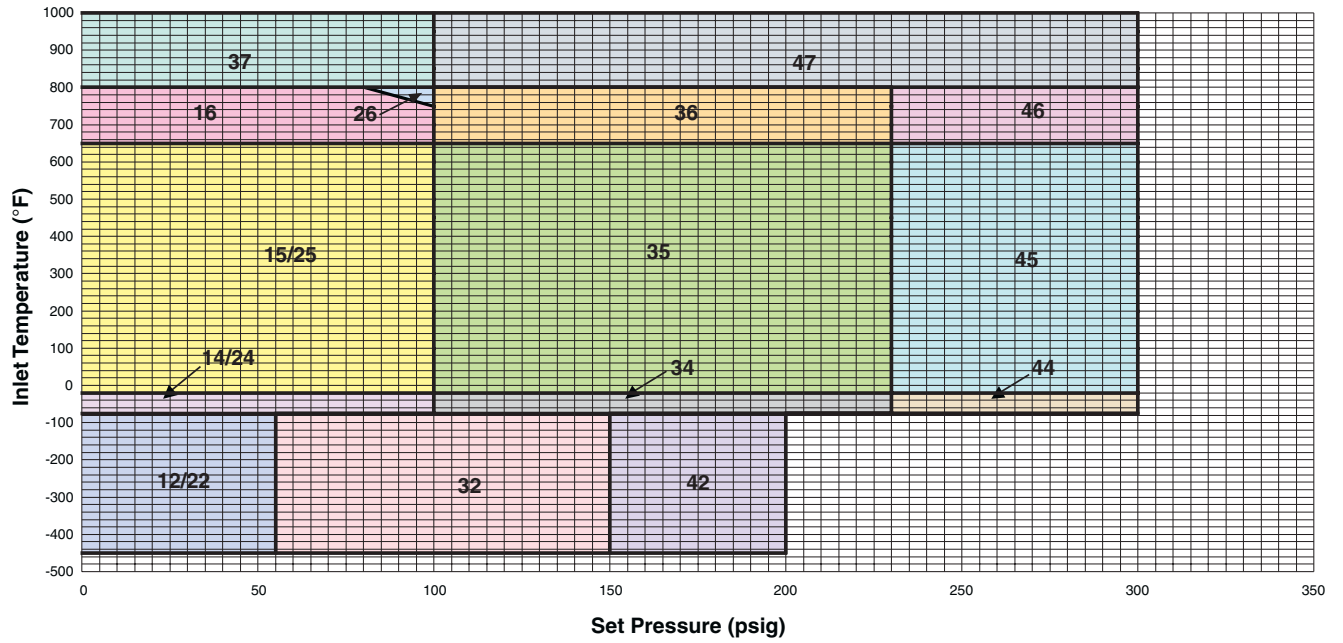

Sizes and Pressure/Temperature Limits

T Orifice, 26.0 sq.in. [16,774 sq.mm] Effective Area

Valve Series	Valve Size Inlet X Orifice X Outlet		Standard Connections ANSI Flanges Raised Face		Maximum Set Pressure - psig						Back Press. Limit@100°F psig		Maximum Set Pressure - barg						Back Press. Limit@38°C barg							
					Inlet								Inlet													
					-450°F to -75°F	-75°F to -21°F	-20°F to +100°F	+650°F	+800°F	+1000°F			-268°C to -60°C	-59°C to -30°C	-29°C to +38°C	+343°C	+427°C	+538°C								
JOS-E-	15	8T10	150	150			65	65				30	30			4.48	4.48				2.06	2.06				
JBS-E-	25	8T10	300	150			65	65				30	30			4.48	4.48				2.06	2.06				
JLT-E-	35	8T10	300	150			120	120				60	60			8.27	8.27				4.13	4.13				
JOS-H-E-	45	8T10	300	150			300	300				100	100			20.6	20.6				6.89	6.89				
JOS-E-	16	8T10	150	150				65	65			30	30				4.48	4.48				2.06	2.06			
JBS-E-	26	8T10	300	150				65	65			30	30				4.48	4.48				2.06	2.06			
JLT-E-	36	8T10	300	150				120	120			60	60				8.27	8.27				4.13	4.13			
JOS-H-E-	46	8T10	300	150				300	300			100	100				20.6	20.6				6.89	6.89			
JOS-E-	37	8T10	300	150					300	215		60	60						20.6	14.8		4.13	4.13			
JBS-E-																										
JLT-E-																										
JOS-H-E-																										
JOS-E-	14	8T10	150	150		65						30	30		4.48						2.06	2.06				
JBS-E-	24	8T10	300	150		65						30	30		4.48						2.06	2.06				
JLT-E-	34	8T10	300	150		120						60	60		8.27						4.13	4.13				
JOS-E-	12	8T10	150	150	50							30	30	3.44							2.06	2.06				
JBS-E-	22	8T10	300	150	50							30	30	3.44							2.06	2.06				
JLT-E-	32	8T10	300	150	65							60	60	4.48							4.13	4.13				

Notes

- Upper temperature limit of JOS-H-E-15, 25, 35 and 45 valves is +800°F [+427°C].
- Outlet pressure for temperatures above +100°F [+38°C] should not exceed the ANSI flange rating.
- Valves set below 15 psig [1.03 barg] cannot be stamped with the ASME Code Symbol. Only metal seated valves may be set below 15 psig.
- Series Designations: JLT-JOS-E and JLT-JBS-E signify Series JOS-E, JBS-E with liquid trim for liquid and gas service.

Low Set Pressure Limits

JOS-E	8 psig [0.55 barg]
JBS-E	8 psig [0.55 barg]
JLT-JOS-E	15 psig [1.03 barg]
JLT-JBS-E	25 psig [1.72 barg]

Dimensions and Weights

Valve Series	Valve Dimensions, inches [mm]							Approx. Weight lbs (kg) Type J
	Center to Face		Use to find Bolt Length X	Approximate Height				
	Inlet	Outlet		Valve (Cap) Type				
	E	F	A & G	J & L	C	D		
JOS-E-, JBS-E-, JLT-E-, JOS-H-E-								
12, 14, 15, 16, 22, 24, 25, 26	10 ⁷ / ₈ [276]	11 [279]	2 ⁹ / ₁₆ [65]	54 [1372]	59 ¹ / ₂ [1511]	58 ¹ / ₂ [1486]	59 ¹ / ₄ [1505]	882 (400)
32, 34, 35, 36, 37	10 ⁷ / ₈ [276]	11 [279]	2 ⁹ / ₁₆ [65]	54 [1372]	59 ¹ / ₂ [1511]	58 ¹ / ₂ [1486]	59 ¹ / ₄ [1505]	902 (409)
45, 46	10 ⁷ / ₈ [276]	11 [279]	2 ⁹ / ₁₆ [65]	54 [1372]	59 ¹ / ₂ [1511]	58 ¹ / ₂ [1486]	59 ¹ / ₄ [1505]	930 (422)

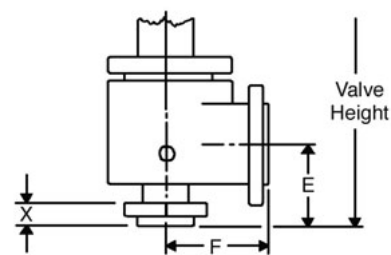

- Type J (Threaded Cap)
- Type C (Regular Lifting Lever) Also JOS-H-E
- Type D (Packed Lifting Lever)
- Type L (Bolted Cap)

Pressure/Temperature Limit Chart
T Orifice, 26.0 sq.in. [16,774 sq.mm] Effective Area

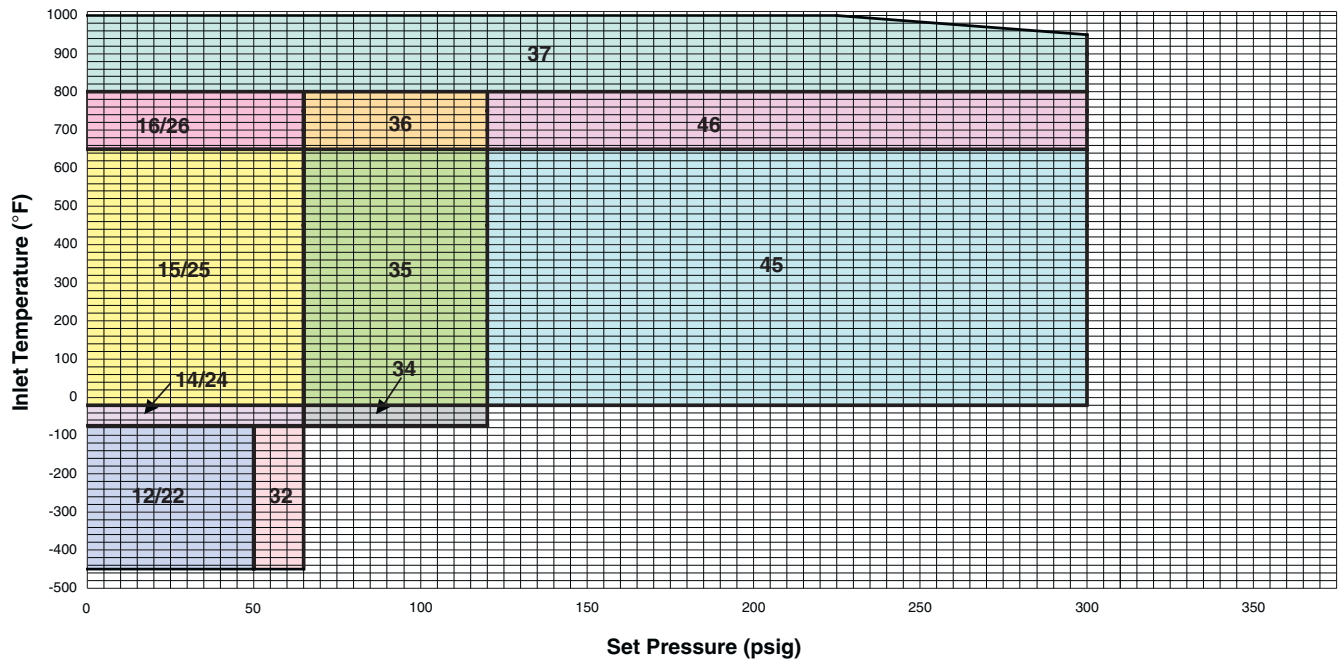

Sizes and Pressure/Temperature Limits

T2 Orifice, 27.872 sq.in. [17,981 sq.mm] Effective Area

Valve Series	Valve Size Inlet X Orifice X Outlet	Standard Connections ANSI Flanges Raised Face		Maximum Set Pressure - psig							Back Press. Limit@100°F psig		Maximum Set Pressure - barg						Back Press. Limit@38°C barg			
				Inlet									Inlet									
				-450°F to -75°F	-75°F to -21°F	-20°F to +100°F	+650°F ¹	+800°F	+1000°F	-268°C to -60°C			-59°C to -30°C	-29°C to +38°C	+343°C ¹	+427°C	+538°C					
				Inlet	Outlet					JOS ²	JBS ²	JOS ²	JBS ²	JOS ²	JBS ²							
JOS-E- JBS-E- JOS-H-E- JOS-H-E-	15	8T210	150	150			65	65				30	30			4.48	4.48			2.06	2.06	
	25	8T210	300	150			65	65				30	30			4.48	4.48			2.06	2.06	
	35	8T210	300	150			120	120				60	60			8.27	8.27			4.13	4.13	
	45	8T210	300	150			300	300				100	100			20.6	20.6			6.89	6.89	
JOS-E- JBS-E- JOS-H-E- JOS-H-E-	16	8T210	150	150				65	65			30	30				4.48	4.48			2.06	2.06
	26	8T210	300	150				65	65			30	30				4.48	4.48			2.06	2.06
	36	8T210	300	150				120	120			60	60				8.27	8.27			4.13	4.13
	46	8T210	300	150				300	300			100	100				20.6	20.6			6.89	6.89
JOS-E- JBS-E- JOS-H-E-	37	8T210	300	150					300	215		60	60						20.6	14.8	4.13	4.13
JOS-E- JBS-E- JOS-H-E-	14	8T210	150	150		65						30	30		4.48						2.06	2.06
	24	8T210	300	150		65						30	30		4.48						2.06	2.06
	34	8T210	300	150		120						60	60		8.27						4.13	4.13
JOS-E- JBS-E- JOS-H-E-	12	8T210	150	150	50							30	30	3.44							2.06	2.06
	22	8T210	300	150	50							30	30	3.44							2.06	2.06
	32	8T210	300	150	65							60	60	4.48							4.13	4.13

Notes

- Upper temperature limit of JOS-H-E-15, 25, 35 and 45 valves is +800°F [+427°C].
- Outlet pressure for temperatures above +100°F [+38°C] should not exceed the ANSI flange rating.
- Valves set below 15 psig [1.03 barg] cannot be stamped with the ASME Code Symbol. Only metal seated valves may be set below 15 psig.
- Series Designations: JLT-JOS-E and JLT-JBS-E signify Series JOS-E, JBS-E with liquid trim for liquid and gas service.

Low Set Pressure Limits

JOS-E	8 psig [0.55 barg]
JBS-E	8 psig [0.55 barg]

Dimensions and Weights

Valve Series	Valve Dimensions, inches [mm]							Approx. Weight lbs (kg) Type J
	Center to Face		Use to find Bolt Length	Approximate Height				
	Inlet	Outlet		Valve (Cap) Type				
	E	F	X	A & G	J & L	C	D	
JOS-E-, JBS-E-, JLT-E-, JOS-H-E-								
12, 14, 15, 16, 22, 24, 25, 26	10 ⁷ / ₈ [276]	11 [279]	2 ⁹ / ₁₆ [65]	54 [1372]	59 ¹ / ₂ [1511]	58 ¹ / ₂ [1486]	59 ¹ / ₄ [1505]	882 (400)
32, 34, 35, 36, 37	10 ⁷ / ₈ [276]	11 [279]	2 ⁹ / ₁₆ [65]	54 [1372]	59 ¹ / ₂ [1511]	58 ¹ / ₂ [1486]	59 ¹ / ₄ [1505]	902 (409)
45, 46	10 ⁷ / ₈ [276]	11 [279]	2 ⁹ / ₁₆ [65]	54 [1372]	59 ¹ / ₂ [1511]	58 ¹ / ₂ [1486]	59 ¹ / ₄ [1505]	930 (422)

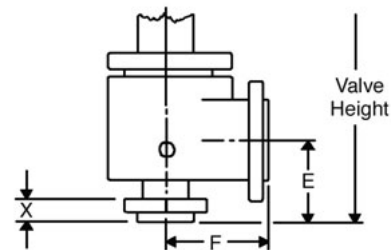

- Type J (Threaded Cap)
- Type C (Regular Lifting Lever) Also JOS-H-E
- Type D (Packed Lifting Lever)
- Type L (Bolted Cap)

Pressure/Temperature Limit Chart

T2 Orifice, 27.872 sq.in. [17,981 sq.mm] Effective Area

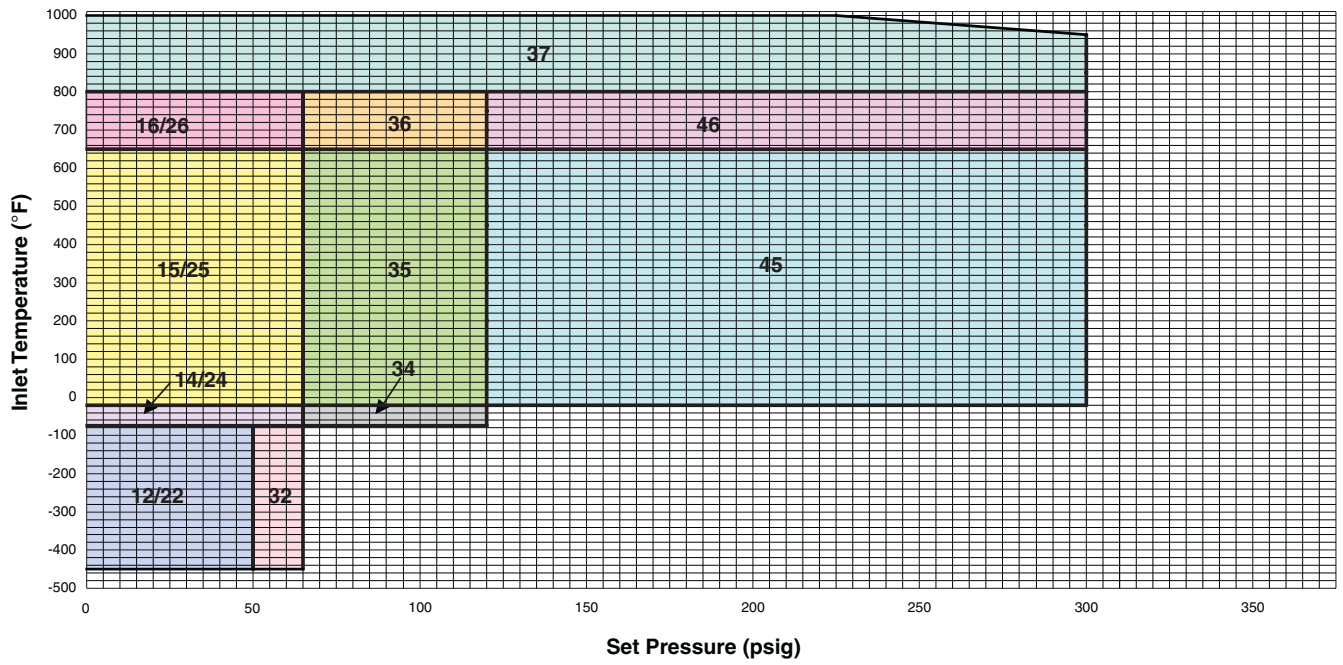

Air Capacities - Series JOS-E and JBS-E, USCS Units¹ (United States Customary System)

Set Pressures 5 - 780 psig

Set Pressure (psig)	Orifice Letter Designation and Effective Area, sq.in.														
	D 0.110	E 0.196	F 0.307	G 0.503	H 0.785	J 1.287	K 1.838	L 2.853	M 3.60	N 4.34	P 6.38	Q 11.05	R 16.0	T 26.0	T2 27.872
1 psi incr. ²	2.1	3.8	6.0	9.8	15.4	25.3	36.1	56.1	70.8	85.3	125	217	314	511	548
5 incr. psi ²	10.8	19.2	30.2	49.4	77.2	126	180	280	354	426	627	1087	1574	2557	2742
5			121	199	311	510	728					4379			
6			128	211	329	540	771	1197				4637			
7			135	221	345	566	808	1255			2807	4862			
8		89.9	140	230	360	590	843	1308	1651	1991	2927	5069	7340	11928	12787
9		93.6	146	240	374	614	877	1362	1719	2072	3047	5277	7641	12417	13312
10	54.5	97.1	152	249	388	637	910	1413	1783	2150	3161	5475	7928	12883	13810
15	64.3	114	179	294	459	752	1075	1668	2105	2538	3731	6463	9359	15208	16303
20	74.1	132	207	339	529	867	1239	1924	2427	2926	4302	7451	10790	17533	18796
30	93.8	167	261	429	669	1098	1568	2434	3071	3703	5443	9428	13652	22184	23782
40	115	205	322	528	824	1351	1929	2995	3780	4557	6699	11602	16800	27300	29266
50	137	244	382	627	978	1604	2291	3557	4488	5411	7954	13777	19948	32416	34750
60	158	282	443	726	1133	1857	2653	4118	5196	6265	9209	15951	23097	37532	40235
70	180	321	503	825	1287	2111	3014	4679	5905	7119	10465	18125	26245	42648	45719
80	202	360	563	924	1442	2364	3376	5241	6613	7973	11720	20300	29393	47764	51203
90	223	398	624	1023	1596	2617	3738	5802	7321	8827	12976	22474	32542	52880	56688
100	245	437	684	1122	1751	2870	4099	6364	8030	9680	14231	24648	35690	57996	62172
120	288	514	805	1319	2059	3377	4823	7486	9447	11388	16742	28997	41986	68228	73141
140	331	591	926	1517	2368	3883	5546	8609	10863	13096	19253	33345	48283	78460	84109
160	375	668	1047	1715	2677	4390	6269	9732	12280	14804	21763	37694	54580	88692	95078
180	418	745	1168	1913	2986	4896	6993	10855	13697	16512	24274	42043	60876	98924	106047
200	461	822	1288	2111	3295	5403	7716	11977	15114	18220	26785	46391	67173	109156	117015
220	505	900	1409	2309	3604	5909	8439	13100	16530	19928	29296	50740	73469	119388	127984
240	548	977	1530	2507	3913	6416	9163	14223	17947	21636	31806	55088	79766	129620	138953
260	591	1054	1651	2705	4222	6922	9886	15346	19364	23344	34317	59437	86063	139852	149922
280	634	1131	1772	2903	4531	7429	10609	16468	20780	25052	36828	63785	92359	150084	160890
300	678	1208	1892	3101	4840	7935	11333	17591	22197	26760	39339	68134	98656	160316	171859
320	721	1285	2013	3299	5149	8442	12056	18714	23614	28468	41850	72483			
340	764	1362	2134	3497	5458	8948	12779	19837	25031	30176	44360	76831			
360	808	1439	2255	3695	5767	9455	13503	20959	26447	31884	46871	81180			
380	851	1517	2376	3893	6076	9961	14226	22082	27864	33592	49382	85528			
400	894	1594	2497	4091	6384	10468	14949	23205	29281	35300	51893	89877			
420	937	1671	2617	4289	6693	10974	15673	24328	30698	37008	54403	94226			
440	981	1748	2738	4487	7002	11481	16396	25451	32114	38716	56914	98574			
460	1024	1825	2859	4685	7311	11987	17119	26573	33531	40424	59425	102923			
480	1067	1902	2980	4883	7620	12494	17843	27696	34948	42132	61936	107271			
500	1111	1979	3101	5081	7929	13000	18566	28819	36365	43840	64446	111620			
520	1154	2057	3221	5278	8238	13506	19289	29942	37781	45548	66957	115969			
540	1197	2134	3342	5476	8547	14013	20013	31064	39198	47256	69468	120317			
560	1241	2211	3463	5674	8856	14519	20736	32187	40615	48963	71979	124666			
580	1284	2288	3584	5872	9165	15026	21459	33310	42032	50671	74490	129014			
600	1327	2365	3705	6070	9474	15532	22182	34433	43448	52379	77000	133363			
620	1370	2442	3826	6268	9783	16039	22906	35555	44865	54087	79511				
640	1414	2519	3946	6466	10092	16545	23629	36678	46282	55795	82022				
660	1457	2596	4067	6664	10401	17052	24352	37801	47698	57503	84533				
680	1500	2674	4188	6862	10709	17558	25076	38924	49115	59211	87043				
700	1544	2751	4309	7060	11018	18065	25799	40046	50532	60919	89554				
720	1587	2828	4430	7258	11327	18571	26522	41169	51949	62627	92065				
740	1630	2905	4550	7456	11636	19078	27246	42292	53365	64335	94576				
760	1673	2982	4671	7654	11945	19584	27969	43415	54782	66043	97087				
780	1717	3059	4792	7852	12254	20091	28692	44538	56199	67751	99597				

Notes

1. For air capacities, USCS Units are exact equivalents of Imperial Units.
2. Not valid below 30 psig set pressure.
3. Capacities below 30 psig set pressure are calculated at 3 psi overpressure.

Shaded values are JOS-E only.

Capacity in standard cubic feet per minute of air at 60°F and 10% overpressure.³ Valve discharging to atmospheric pressure.

Capacities certified by the National Board of Boiler and Pressure Vessel Inspectors and in accordance with the ASME Boiler and Pressure Vessel Code, Section VIII.

Air Capacities - Series JOS-E and JBS-E, USCS Units¹ (United States Customary System)

Set Pressures 800 - 6000 psig

Set Pressure (psig)	Orifice Letter Designation and Effective Area, sq.in.														
	D 0.110	E 0.196	F 0.307	G 0.503	H 0.785	J 1.287	K 1.838	L 2.853	M 3.60	N 4.34	P 6.38	Q 11.05	R 16.0	T 26.0	T2 27.872
1 psi incr. ²	2.1	3.8	6.0	9.8	15.4	25.3	36.1	56.1	70.8	85.3	125	217	314	511	548
5 incr. psi ²	10.8	19.2	30.2	49.4	77.2	126	180	280	354	426	627	1087	1574	2557	2742
800	1760	3136	4913	8050	12563	20597	29416	45660	57616	69459	102108				
820	1803	3214	5034	8248	12872	21104	30139	46783	59032	71167	104619				
840	1847	3291	5155	8446	13181	21610	30862	47906	60449	72875	107130				
860	1890	3368	5275	8644	13490	22117	31586	49029	61866	74583	109640				
880	1933	3445	5396	8842	13799	22623	32309	50151	63283	76291	112151				
900	1976	3522	5517	9039	14108	23130	33032	51274	64699	77999	114662				
920	2020	3599	5638	9237	14417	23636	33756	52397	66116	79707	117173				
940	2063	3676	5759	9435	14726	24143	34479	53520	67533	81415	119683				
960	2106	3753	5879	9633	15034	24649	35202	54642	68950	83123	122194				
980	2150	3831	6000	9831	15343	25156	35926	55765	70366	84831	124705				
1000	2193	3908	6121	10029	15652	25662	36649	56888	71783	86538	127216				
1100	2409	4293	6725	11019	17197	28195	40266	62502	78867						
1200	2626	4679	7329	12009	18742	30727	43882	68116							
1300	2842	5065	7933	12998	20286	33259	47499	73729							
1400	3059	5450	8537	13988	21831	35792	51115	79343							
1480	3232	5759	9021	14780	23067	37818	54009	83834							
1500	3275	5836	9141	14978	23375	38324	54732								
1600	3492	6222	9746	15968	24920	40857	58349								
1700	3708	6607	10350	16957	26465	43389	61965								
1800	3924	6993	10954	17947	28009	45921	65582								
1900	4141	7379	11558	18937	29554	48454	69198								
2000	4357	7764	12162	19927	31099	50986	72815								
2100	4574	8150	12766	20916	32643	53519	76432								
2200	4790	8536	13370	21906	34188	56051	80048								
2300	5007	8921	13974	22896	35733	58584									
2400	5223	9307	14578	23886	37277	61116									
2500	5440	9693	15182	24875	38822	63648									
2600	5656	10078	15786	25865	40366	66181									
2700	5872	10464	16390	26855	41911	68713									
2800	6089	10850	16994	27845											
2900	6305	11235	17599	28834											
3000	6522	11621	18203	29824											
3100	6738	12007	18807	30814											
3200	6955	12392	19411	31804											
3300	7171	12778	20015	32793											
3400	7388	13164	20619	33783											
3500	7604	13549	21223	34773											
3600	7820	13935	21827	35763											
3700	8037	14321	22431	36752											
3800	8253	14706	23035												
3900	8470	15092	23639												
4000	8686	15478	24243												
4200	9119	16249	25452												
4400	9552	17020	26660												
4600	9985	17792	27868												
4800	10418	18563	29076												
5000	10851	19334	30284												
5200	11284	20106													
5400	11717	20877													
5600	12149	21648													
5800	12582	22420													
6000	13015	23191													

Capacity in standard cubic feet per minute of air at 60°F and 10% overpressure. Valve discharging to atmospheric pressure.

Note

1. For air capacities, USCS Units are exact equivalents of Imperial Units.

Capacities certified by the National Board of Boiler and Pressure Vessel Inspectors and in accordance with the ASME Boiler and Pressure Vessel Code, Section VIII.

Water Capacities - Series JLT-JOS-E and JLT-JBS-E, USCS Units¹ (United States Customary System)

Differential Pressures ΔP^2 , 5 - 1040 psi³

Differential Pressure ΔP - psi	Orifice Letter Designation and Effective Area, sq.in.													
	D 0.110	E 0.196	F 0.307	G 0.503	H 0.785	J 1.287	K 1.838	L 2.853	M 3.60	N 4.34	P 6.38	Q 11.05	R 16.0	T 26.0
5	6.9	12.3	19.3	31.6	49.3	80.9	115	179	226	273	401	695	1006	1635
10	9.7	17.4	27.3	44.7	69.8	114	163	253	320	386	567	983	1423	2313
15	11.9	21.3	33.4	54.8	85.5	140	200	310	392	472	695	1204	1743	2833
20	13.8	24.6	38.6	63.3	98.7	161	231	359	453	546	802	1390	2013	3271
40	19.5	34.8	54.6	89.5	139	229	327	507	640	772	1135	1966	2847	4627
60	23.9	42.7	66.9	109	171	280	400	621	784	945	1390	2408	3487	5667
80	27.6	49.3	77.2	126	197	323	462	718	906	1092	1605	2781	4027	6543
100	30.9	55.1	86.3	141	220	362	517	802	1013	1221	1795	3109	4502	7316
120	33.9	60.4	94.6	155	241	396	566	879	1109	1337	1966	3406	4932	8014
140	36.6	65.2	102	167	261	428	611	949	1198	1445	2124	3679	5327	8656
160	39.1	69.7	109	179	279	458	654	1015	1281	1544	2270	3933	5695	9254
180	41.5	73.9	115	189	296	485	693	1077	1359	1638	2408	4171	6040	9815
200	43.7	78.0	122	200	312	512	731	1135	1432	1727	2538	4397	6367	10346
220	45.9	81.8	128	209	327	537	767	1190	1502	1811	2662	4612	6678	10851
240	47.9	85.4	133	219	342	561	801	1243	1569	1891	2781	4817	6975	11334
260	49.9	88.9	139	228	356	583	833	1294	1633	1969	2894	5013	7259	11797
280	51.7	92.2	144	236	369	606	865	1343	1695	2043	3004	5203	7533	12242
300	53.6	95.5	149	245	382	627	895	1390	1754	2115	3109	5385	7798	12672
320	55.3	98.6	154	253	395	647	925	1436	1812	2184	3211	5562	8054	13087
340	57.0	101	159	260	407	667	953	1480	1867	2251	3310	5733		
360	58.7	104	163	268	419	687	981	1523	1922	2317	3406	5899		
380	60.3	107	168	275	430	705	1008	1565	1974	2380	3499	6061		
400	61.9	110	172	283	441	724	1034	1605	2026	2442	3590	6218		
420	63.4	113	177	290	452	742	1059	1645	2076	2502	3679	6372		
440	64.9	115	181	296	463	759	1084	1684	2124	2561	3765	6522		
460	66.3	118	185	303	473	776	1109	1721	2172	2619	3850	6669		
480	67.8	120	189	310	483	793	1133	1758	2219	2675	3933	6812		
500	69.2	123	193	316	493	809	1156	1795	2265	2730	4014	6952		
520	70.5	125	196	322	503	825	1179	1830	2310	2784	4093	7090		
540	71.9	128	200	328	513	841	1201	1865	2354	2837	4171	7225		
560	73.2	130	204	334	522	857	1223	1899	2397	2890	4248	7358		
580	74.5	132	208	340	531	872	1245	1933	2439	2941	4323	7488		
600	75.8	135	211	346	541	887	1266	1966	2481	2991	4397	7616		
620	77.0	137	215	352	550	901	1287	1999	2522	3040	4470	7742		
640	78.3	139	218	358	558	916	1308	2031	2562	3089	4541	7866		
660	79.5	141	221	363	567	930	1328	2062	2602	3137	4612	7988		
680	80.7	143	225	369	576	944	1348	2093	2641	3184	4681			
700	81.8	145	228	374	584	958	1368	2124	2680	3231	4750			
720	83.0	147	231	379	592	971	1387	2154	2718	3277	4817			
740	84.2	150	235	385	600	985	1406	2183	2755	3322	4883			
760	85.3	152	238	390	608	998	1425	2213	2792	3366	4949			
780	86.4	154	241	395	616	1011	1444	2242	2829	3410	5014			
800	87.5	156	244	400	624	1024	1462	2270	2865	3454	5077			
820	88.6	157	247	405	632	1037	1481	2298	2900	3497	5141			
840	89.7	159	250	410	640	1049	1499	2326	2936	3539	5203			
860	90.7	161	253	415	647	1062	1516	2354	2970	3581	5264			
880	91.8	163	256	419	655	1074	1534	2381	3005	3622	5325			
900	92.8	165	259	424	662	1086	1551	2408	3039	3663	5385			
920	93.8	167	262	429	670	1098	1568	2435	3072	3704	5445			
940	94.9	169	264	433	677	1110	1585	2461	3105	3744	5504			
960	95.9	170	267	438	684	1122	1602	2487	3138	3783	5562			
980	96.9	172	270	443	691	1133	1619	2513	3171	3823	5620			
1000	97.8	174	273	447	698	1145	1635	2538	3203	3862	5677			
1020	98.8	176	275	452	705	1156	1651	2564	3235	3900	5733			
1040	99.8	177	278	456	712	1167	1667	2589	3266	3938	5789			

Notes

- USCS Units for water and liquids are U.S. gallons per minute (1 U.S. gallon equals 0.8327 Imperial gallon).
- Differential Pressure (ΔP) equals inlet pressure (set pressure plus overpressure) at flowing conditions minus back pressure.
- See pages 18 to 47 for Minimum and Maximum Set Pressure Limits.

Capacity in U.S. gallons per minute of water at 70°F and 10% overpressure.

Capacities certified by the National Board of Boiler and Pressure Vessel Inspectors and in accordance with the ASME Boiler and Pressure Vessel Code, Section VIII.

**Water Capacities - Series JLT-JOS-E and JLT-JBS-E, USCS Units¹ (United States Customary System)
Differential Pressures ΔP^2 , 1060 - 6600 psi³**

Differential Pressure ΔP - psi	Orifice Letter Designation and Effective Area, sq.in.													
	D 0.110	E 0.196	F 0.307	G 0.503	H 0.785	J 1.287	K 1.838	L 2.853	M 3.60	N 4.34	P 6.38	Q 11.05	R 16.0	T 26.0
1060	100	179	281	460	719	1179	1683	2613	3298	3976	5845			
1080	101	181	283	465	725	1190	1699	2638	3329	4013	5900			
1100	102	182	286	469	732	1201	1715	2662	3359	4050	5954			
1120	103	184	289	473	739	1212	1730	2686	3390					
1140	104	186	291	477	745	1222	1746	2710	3420					
1160	105	187	294	482	752	1233	1761	2734	3450					
1180	106	189	296	486	758	1244	1776	2757	3479					
1200	107	191	299	490	765	1254	1791	2781	3509					
1220	108	192	301	494	771	1264	1806	2804						
1240	109	194	304	498	777	1275	1821	2827						
1260	109	195	306	502	784	1285	1835	2849						
1280	110	197	309	506	790	1295	1850	2872						
1300	111	198	311	510	796	1305	1864	2894						
1320	112	200	313	514	802	1315	1879	2916						
1340	113	201	316	518	808	1325	1893	2938						
1360	114	203	318	521	814	1335	1907	2960						
1380	114	204	320	525	820	1345	1921	2982						
1400	115	206	323	529	826	1355	1935	3003						
1420	116	207	325	533	832	1364	1949	3025						
1440	117	209	327	537	838	1374	1962	3046						
1460	118	210	330	540	844	1383	1976	3067						
1480	119	212	332	544	849	1393	1989	3088						
1500	119	213	334	548	855	1402	2003	3109						
1600	123	220	345	566	883	1448	2068	3211						
1700	127	227	356	583	910	1493	2132							
1800	131	234	366	600	937	1536	2194							
1900	134	240	376	616	962	1578	2254							
2000	138	246	386	633	987	1619	2313							
2100	141	252	395	648	1012	1659	2370							
2200	145	258	405	663	1036	1698	2425							
2300	148	264	414	678	1059	1736	2480							
2400	151	270	423	693	1082	1774	2533							
2500	154	275	431	707	1104	1810								
2600	157	281	440	721	1126	1846								
2700	160	286	448	735	1147	1881								
2800	163	291	457	748	1168	1916								
2900	166	297	465	762	1189	1950								
3000	169	302	473	775	1209	1983								
3100	172	307	480	788										
3200	175	312	488	800										
3300	177	316	496	813										
3400	180	321	503	825										
3500	183	326	511	837										
3600	185	330	518	849										
3700	188	335	525	860										
3800	190	339	532											
3900	193	344	539	883										
4000	195	348	546	895										
4100	198	353	553											
4200	200	357	559											
4300	202	361	566											
4400	205	365	573											
4500	207	369	579											
4600	209	374	585											
4700	212	378	592											
4800	214	382	598											
4900	216	386	604											
5000	218	390	610											
5500	229	409	640											
6000	239	427												
6600	251	448												

Capacity in U.S. gallons per minute of water at 70°F and 10% overpressure.

Capacities certified by the National Board of Boiler and Pressure Vessel Inspectors and in accordance with the ASME Boiler and Pressure Vessel Code, Section VIII.

Notes

1. USCS Units for water and liquids are U.S. gallons per minute (1 U.S. gallon equals 0.8327 Imperial gallon).
2. Differential Pressure (ΔP) equals inlet pressure (set pressure plus overpressure) at flowing conditions minus back pressure.
3. See pages 18 to 47 for Minimum and Maximum Set Pressure Limits.

Saturated Steam Capacities, Unfired Pressure Vessel Service - Series JOS-E and JBS-E, USCS Units¹
Set Pressures 5 - 550 psig

Set Pressure (psig)	Orifice Letter Designation and Effective Area, sq.in.															
	D 0.110	E 0.196	F 0.307	G 0.503	H 0.785	J 1.287	K 1.838	L 2.853	M 3.60	N 4.34	P 6.38	Q 11.05	R 16.0	T 26.0	T2 27.872	
1 psi incr. ² 5 incr. psi ²	6.0 30.3	10.8 54.1	16.9 84.7	27.7 138	43.3 216	71.0 355	101 507	157 787	198 994	239 1198	352 1761	610 3051	883 4418	1436 7180	1539 7697	
5			341	559	873	1431	2044					12292				
6			361	592	924	1516	2165	3361				13018				
7			379	621	969	1589	2270	3524			7881	13649				
8		252	395	647	1010	1657	2367	3674	4636	5589	8216	14231	20606	33484	35895	
9		262	411	674	1052	1725	2464	3824	4826	5818	8553	14814	21450	34857	37367	
10	152	272	427	699	1091	1790	2556	3968	5007	6036	8873	15369	22254	36163	38766	
15	180	321	504	825	1288	2113	3017	4684	5911	7126	10475	18143	26271	42690	45764	
20	208	371	581	952	1486	2436	3479	5400	6814	8215	12077	20917	30288	49218	52762	
30	263	469	735	1204	1880	3082	4402	6833	8622	10394	15280	26466	38322	62273	66757	
40	324	577	904	1482	2313	3793	5417	8409	10610	12792	18804	32569	47159	76634	82151	
50	384	685	1074	1760	2747	4504	6432	9984	12599	15189	22328	38672	55996	90995	97546	
60	445	794	1244	2038	3180	5215	7447	11560	14587	17586	25852	44776	64834	105355	112941	
70	506	902	1413	2316	3614	5925	8463	13136	16576	19983	29376	50879	73671	119716	128336	
80	567	1010	1583	2593	4048	6636	9478	14712	18564	22380	32900	56982	82509	134077	143730	
90	628	1118	1752	2871	4481	7347	10493	16288	20552	24777	36424	63086	91346	148438	159125	
100	688	1227	1922	3149	4915	8058	11508	17864	22541	27174	39948	69189	100183	162798	174520	
110	749	1335	2091	3427	5348	8769	12523	19439	24529	29572	43472	75292	109021	177159	189915	
120	810	1443	2261	3705	5782	9480	13539	21015	26518	31969	46996	81396	117858	191520	205309	
130	871	1552	2430	3983	6216	10191	14554	22591	28506	34366	50520	87499	126696	205881	220704	
140	931	1660	2600	4260	6649	10901	15569	24167	30495	36763	54044	93602	135533	220242	236099	
150	992	1768	2770	4538	7083	11612	16584	25743	32483	39160	57567	99706	144370	234602	251494	
160	1053	1876	2939	4816	7516	12323	17599	27318	34471	41557	61091	105809	153208	248963	266888	
170	1114	1985	3109	5094	7950	13034	18615	28894	36460	43954	64615	111912	162045	263324	282283	
180	1174	2093	3278	5372	8383	13745	19630	30470	38448	46352	68139	118016	170883	277685	297678	
190	1235	2201	3448	5649	8817	14456	20645	32046	40437	48749	71663	124119	179720	292045	313073	
200	1296	2309	3617	5927	9251	15167	21660	33622	42425	51146	75187	130222	188557	306406	328468	
210	1357	2418	3787	6205	9684	15877	22675	35198	44413	53543	78711	136326	197395	320767	343862	
220	1417	2526	3957	6483	10118	16588	23690	36773	46402	55940	82235	142429	206232	335128	359257	
230	1478	2634	4126	6761	10551	17299	24706	38349	48390	58337	85759	148532	215070	349489	374652	
240	1539	2742	4296	7039	10985	18010	25721	39925	50379	60734	89283	154636	223907	363849	390047	
250	1600	2851	4465	7316	11419	18721	26736	41501	52367	63132	92807	160739	232744	378210	405441	
260	1660	2959	4635	7594	11852	19432	27751	43077	54356	65529	96330	166842	241582	392571	420836	
270	1721	3067	4804	7872	12286	20143	28766	44652	56344	67926	99854	172946	250419	406932	436231	
280	1782	3175	4974	8150	12719	20853	29782	46228	58332	70323	103378	179049	259257	421292	451626	
290	1843	3284	5144	8428	13153	21564	30797	47804	60321	72720	106902	185152	268094	435653	467020	
300	1903	3392	5313	8706	13586	22275	31812	49380	62309	75117	110426	191256	276931	450014	482415	
310	1964	3500	5483	8983	14020	22986	32827	50956	64298	77514	113950	197359				
320	2025	3608	5652	9261	14454	23697	33842	52532	66286	79912	117474	203462				
330	2086	3717	5822	9539	14887	24408	34858	54107	68274	82309	120998	209566				
340	2146	3825	5991	9817	15321	25119	35873	55683	70263	84706	124522	215669				
350	2207	3933	6161	10095	15754	25830	36888	57259	72251	87103	128046	221772				
360	2268	4041	6331	10373	16188	26540	37903	58835	74240	89500	131570	227876				
370	2329	4150	6500	10650	16622	27251	38918	60411	76228	91897	135094	233979				
380	2389	4258	6670	10928	17055	27962	39934	61986	78217	94294	138617	240088				
390	2450	4366	6839	11206	17489	28673	40949	63562	80205	96692	142141	246186				
400	2511	4474	7009	11484	17922	29384	41964	65138	82193	99089	145665	252289				
410	2572	4583	7178	11762	18356	30095	42979	66714	84182	101486	149189	258392				
420	2632	4691	7348	12039	18789	30806	43994	68290	86170	103883	152713	264496				
430	2693	4799	7518	12317	19223	31516	45010	69866	88159	106280	156237	270599				
440	2754	4908	7687	12595	19657	32227	46025	71441	90147	108677	159761	276702				
450	2815	5016	7857	12873	20090	32938	47040	73017	92135	111074	163285	282806				
460	2876	5124	8026	13151	20524	33649	48055	74593	94124	113472	166809	288909				
470	2936	5232	8196	13429	20957	34360	49070	76169	96112	115869	170333	295012				
480	2997	5341	8365	13706	21391	35071	50086	77745	98101	118266	173857	301116				
490	3058	5449	8535	13984	21825	35782	51101	79320	100089	120663	177380	307219				
500	3119	5557	8704	14262	22258	36492	52116	80896	102077	123060	180904	313322				
510	3179	5665	8874	14540	22692	37203	53131	82472	104066	125457	184428	319426				
520	3240	5774	9044	14818	23125	37914	54146	84048	106054	127854	187952	325529				
530	3301	5882	9213	15096	23559	38625	55162	85624	108043	130252	191476	331632				
540	3362	5990	9383	15373	23993	39336	56177	87200	110031	132649	195000	337736				
550	3422	6098	9552	15651	24426	40047	57192	88775	112020	135046	198524	343839				

Notes

1. USCS - United States Customary System.
2. Not valid below 30 psig set pressure.
3. Capacities below 30 psig set pressure are calculated at 3 psig overpressure.

Shaded values are JOS-E only.

Capacity in pounds per hour of steam at 10% overpressure.³ Valve discharging to atmospheric pressure.

Capacities certified by the National Board of Boiler and Pressure Vessel Inspectors and in accordance with the ASME Boiler and Pressure Vessel Code, Section VIII.

Saturated Steam Capacities, Unfired Pressure Vessel Service - Series JOS-E and JBS-E, USCS Units¹
Set Pressures 560 - 1700 psig

Set Pressure (psig)	Orifice Letter Designation and Effective Area, sq. in.														
	D 0.110	E 0.196	F 0.307	G 0.503	H 0.785	J 1.287	K 1.838	L 2.853	M 3.60	N 4.34	P 6.38	Q 11.05	R 16.0	T 26.0	T2 27.872
1 psi incr. 5 incr. psi	6.0 30.3	10.8 54.1	16.9 84.7	27.7 138	43.3 216	71.0 355	101 507	157 787	198 994	239 1198	352 1761	610 3051	883 4418	1436 7180	1539 7697
560	3483	6207	9722	15929	24860	40758	58207	90351	114008	137443	202048	349942			
570	3544	6315	9891	16207	25293	41468	59222	91927	115996	139840	205572	356046			
580	3605	6423	10061	16485	25727	42179	60238	93503	117985	142237	209096	362149			
590	3665	6531	10231	16762	26160	42890	61253	95079	119973	144634	212620	368252			
600	3726	6640	10400	17040	26594	43601	62268	96655	121962	147032	216144	374356			
620	3848	6856	10739	17596	27461	45023	64298	99806	125938	151826	223191				
640	3969	7073	11078	18152	28328	46444	66329	102958	129915	156620	230239				
660	4091	7289	11418	18707	29196	47866	68359	106109	133892	161415	237287				
680	4212	7506	11757	19263	30063	49288	70390	109261	137869	166209	244335				
700	4334	7722	12096	19819	30930	50710	72420	112413	141846	171003	251383				
720	4455	7939	12435	20374	31797	52131	74450	115564	145823	175797	258430				
740	4577	8155	12774	20930	32664	53553	76481	118716	149799	180592	265478				
760	4698	8372	13113	21486	33531	54975	78511	121868	153776	185386	272526				
780	4820	8588	13452	22041	34399	56396	80541	125019	157753	190180	279574				
800	4941	8805	13792	22597	35266	57818	82572	128171	161730	194975	286622				
820	5063	9021	14131	23152	36133	59240	84602	131323	165707	199769	293670				
840	5184	9238	14470	23708	37000	60662	86633	134474	169684	204563	300717				
860	5306	9454	14809	24264	37867	62083	88663	137626	173660	209357	307765				
880	5427	9671	15148	24819	38734	63505	90693	140777	177637	214152	314813				
900	5549	9887	15487	25375	39602	64927	92724	143929	181614	218946	321861				
920	5670	10104	15826	25931	40469	66348	94754	147081	185591	223740	328909				
940	5792	10320	16165	26486	41336	67770	96785	150232	189568	228535	335957				
960	5913	10537	16505	27042	42203	69192	98815	153384	193545	233329	343004				
980	6035	10753	16844	27598	43070	70614	100845	156536	197521	238123	350052				
1000	6156	10970	17183	28153	43937	72035	102876	159687	201498	242917	357100				
1020	6278	11187	17522	28709	44805	73457	104906	162839	205475						
1040	6399	11403	17861	29265	45672	74879	106937	165991	209452						
1060	6521	11620	18200	29820	46539	76300	108967	169142	213429						
1080	6642	11836	18539	30376	47406	77722	110997	172294	217406						
1100	6764	12053	18879	30932	48273	79144	113028	175445	221382						
1120	6885	12269	19218	31487	49140	80566	115058	178597							
1140	7007	12486	19557	32043	50008	81987	117089	181749							
1160	7129	12702	19896	32599	50875	83409	119119	184900							
1180	7250	12919	20235	33154	51742	84831	121149	188052							
1200	7372	13135	20574	33710	52609	86252	123180	191204							
1220	7493	13352	20913	34266	53476	87674	125210	194355							
1240	7615	13568	21252	34821	54343	89096	127241	197507							
1260	7736	13785	21592	35377	55211	90518	129271	200659							
1280	7858	14001	21931	35932	56078	91939	131301	203810							
1300	7979	14218	22270	36488	56945	93361	133332	206962							
1320	8101	14434	22609	37044	57812	94783	135362	210113							
1340	8222	14651	22948	37599	58679	96204	137392	213265							
1360	8312	14811	23200	38012	59323	97259	138899	215603							
1380	8443	15045	23565	38610	60257	98791	141087	219000							
1400	8575	15279	23932	39211	61195	100329	143282	222408							
1420	8706	15514	24300	39814	62136	101871	145485	225827							
1440	8839	15749	24669	40419	63080	103419	147695	229257							
1460	8971	15986	25039	41026	64027	104972	149913	232700							
1480	9105	16223	25411	41635	64977	106530	152139	236155							
1500	9238	16461	25784	42246	65931	108094	154372	239622							
1520	9373	16700	26159	42860	66889	109664	156614								
1540	9507	16940	26535	43475	67850	111239	158864								
1560	9642	17181	26912	44094	68814	112821	161123								
1580	9778	17423	27290	44714	69783	114408	163390								
1600	9914	17666	27671	45337	70755	116002	165666								
1620	10051	17909	28052	45962	71731	117602	167951								
1640	10188	18154	28436	46590	72711	119209	170246								
1660	10326	18400	28821	47221	73695	120823	172550								
1680	10465	18647	29207	47854	74683	122443	174864								
1700	10604	18895	29595	48490	75676	124070	177189								

Capacity in pounds per hour of steam at 10% overpressure. Valve discharging to atmospheric pressure.

Note

1. USCS - United States Customary System.

Capacities certified by the National Board of Boiler and Pressure Vessel Inspectors and in accordance with the ASME Boiler and Pressure Vessel Code, Section VIII.

Saturated Steam Capacities, Unfired Pressure Vessel Service - Series JOS-E and JBS-E, USCS Units¹
Set Pressures 1720 - 2900 psig

Set Pressure (psig)	Orifice Letter Designation and Effective Area, sq.in.														
	D 0.110	E 0.196	F 0.307	G 0.503	H 0.785	J 1.287	K 1.838	L 2.853	M 3.60	N 4.34	P 6.38	Q 11.05	R 16.0	T 26.0	T2 27.872
1 psi incr. 5 incr. psi	6.0 30.3	10.8 54.1	16.9 84.7	27.7 138	43.3 216	71.0 355	101 507	157 787	198 994	239 1198	352 1761	610 3051	883 4418	1436 7180	1539 7697
1720	10744	19143	29985	49129	76673	125705	179523								
1740	10884	19394	30377	49771	77674	127347	181868								
1760	11025	19645	30770	50416	78681	128996	184223								
1780	11167	19897	31166	51063	79691	130654	186590								
1800	11309	20151	31563	51714	80707	132319	188968								
1820	11452	20406	31962	52368	81728	133992	191358								
1840	11596	20662	32363	53025	82753	135674	193759								
1860	11740	20919	32766	53686	83784	137364	196173								
1880	11885	21178	33172	54350	84821	139063	198600								
1900	12031	21438	33579	55017	85862	140771	201039								
1920	12178	21699	33989	55688	86910	142488	203491								
1940	12326	21962	34400	56363	87963	144215	205957								
1960	12474	22227	34815	57042	89022	145951									
1980	12623	22493	35231	57725	90087	147698									
2000	12773	22760	35650	58411	91159	149454									
2020	12924	23029	36072	59102	92237	151222									
2040	13076	23300	36496	59797	93321	153000									
2060	13229	23573	36923	60496	94413	154789									
2080	13383	23847	37352	61200	95511	156590									
2100	13538	24123	37785	61908	96617	158402									
2120	13694	24401	38220	62621	97730	160227									
2140	13851	24681	38658	63340	98850	162064									
2160	14009	24962	39100	64063	99979	163915									
2180	14169	25246	39544	64791	101115	165778									
2200	14329	25532	39992	65525	102260	167655									
2220	14491	25820	40443	66264	103414	169546									
2240	14654	26110	40898	67008	104576	171452									
2260	14818	26403	41356	67759	105747	173372									
2280	14983	26698	41818	68516	106928	175308									
2300	15150	26995	42283	69279	108119	177260									
2320	15318	27295	42753	70048	109319	179229									
2340	15488	27597	43226	70824	110530	181214									
2360	15659	27902	43704	71606	111752	183217									
2380	15832	28210	44186	72396	112985	185237									
2400	16006	28520	44673	73193	114229	187277									
2420	16182	28834	45164	73998	115484	189336									
2440	16360	29151	45660	74811	116752	191415									
2460	16539	29470	46160	75631	118033										
2480	16720	29793	46666	76460	119327										
2500	16904	30120	47177	77298											
2520	17089	30450	47694	78144											
2540	17276	30783	48217	79000											
2560	17465	31120	48745	79866											
2580	17657	31461	49279	80741											
2600	17850	31807	49820	81627											
2620	18046	32156	50367	82523											
2640	18245	32510	50921	83431											
2660	18446	32868	51482	84351											
2680	18650	33231	52051	85282											
2700	18856	33599	52627	86226											
2720	19066	33972	53211	87183											
2740	19278	34350	53803	88154											
2760	19493	34734	54405	89139											
2780	19712	35123	55015	90138											
2800	19934	35519	55634	91153											
2820	20159	35921	56264	92185											
2840	20388	36329	56903	93233											
2860	20621	36744	57553	94298											
2880	20858	37166	58215	95382											
2900	21100	37596	58888	96485											

Note

1. USCS - United States Customary System.

Capacity in pounds per hour of steam at 10% overpressure. Valve discharging to atmospheric pressure.

Capacities certified by the National Board of Boiler and Pressure Vessel Inspectors and in accordance with the ASME Boiler and Pressure Vessel Code, Section VIII.

Equivalents and Conversion Factors

Atmospheres	14.70	Pounds per square inch
Atmospheres	1.033	Kilograms per sq. cm
Atmospheres	29.92	Inches of mercury
Atmospheres	760.0	Millimeters of mercury
Atmospheres	407.2	Inches of water
Atmospheres	33.93	Feet of water
Atmospheres	1.013	Bars
Atmospheres	101.3	KiloPascals
Barrels	42.00	Gallons (U.S.)
Bars	14.50	Pounds per square inch
Bars	1.020	Kilograms per sq. cm
Bars	100.0	KiloPascals
Centimeters	0.3937	Inches
Centimeters	0.03281	Feet
Centimeters	0.010	Meters
Centimeters	0.01094	Yards
Cubic centimeters	0.06102	Cubic inches
Cubic feet	7.481	Gallons
Cubic feet	0.1781	Barrels
Cubic feet per minute	0.02832	Cubic meters per minute
Cubic feet per second	448.8	Gallons per minute
Cubic inches	16.39	Cubic centimeters
Cubic inches	0.004329	Gallons
Cubic meters	264.2	Gallons
Cubic meters per hour	4.403	Gallons per minute
Cubic meters per minute	35.31	Cubic feet per minute
Standard cubic feet per min.	60.00	Standard cubic ft. per hr
Standard cubic feet per min.	1440	Standard cubic ft. per day
Standard cubic feet per min.	0.02716	Nm ³ /min.
Standard cubic feet per min.	1.630	Nm ³ /hr.
Standard cubic feet per min.	39.11	Nm ³ /day
Standard cubic feet per min.	0.02832	Sm ³ /min.
Standard cubic feet per min.	1.699	Sm ³ /hr.
Standard cubic feet per min.	40.78	Sm ³ /day
Feet	0.3048	Meters
Feet	0.3333	Yards
Feet	30.48	Centimeters
Feet of water	0.8818	Inches of mercury
Feet of water	0.4335	Pounds per square inch
Gallons(U.S.)	3785	Cubic centimeters
Gallons(U.S.)	0.1337	Cubic feet
Gallons(U.S.)	231.0	Cubic inches
Gallons(Imperial)	277.4	Cubic inches
Gallons(U.S.)	0.8327	Gallons (Imperial)
Gallons(U.S.)	3.785	Liters
Gallons of water	8.337	Pounds (at 60°F)
Gallons of liquid per minute per minute	500 x Sp. Gr.	Pounds per hour liquid (at 60°F)
Gallons per minute	0.002228	Cubic feet per second
Gallons per minute	227.0 x SG	Kilograms per hour
Gallons per minute	0.06309	Liters per second
Gallons per minute	3.785	Liters per minute
Gallons per minute	0.2271	M ³ /hr.
Grams	0.03527	Ounces
Inches	2.540	Centimeters
Inches	0.08333	Feet
Inches	0.0254	Meters
Inches	0.02778	Yards
Inches of mercury	1.133	Feet of water
Inches of mercury	0.4912	Pounds per square inch
Inches of mercury	0.03342	Atmospheres
Inches of mercury	0.03453	Kilograms per sq. cm
Inches of water	0.03613	Pounds per sq. in.
Inches of water	0.07355	Inches of mercury

Kilograms	2.205	Pounds
Kilograms	0.001102	Short tons (2000 lbs.)
Kilograms	35.27	Ounces
Kilograms per minute	132.3	Pounds per hour
Kilograms per sq. cm	14.22	Pounds per sq. in.
Kilograms per sq. cm	0.9678	Atmospheres
Kilograms per sq. cm	28.96	Inches of mercury
Kilograms per cubic meter	16.018	Pounds per cubic foot
KiloPascals	0.1450	Pounds per sq. in.
KiloPascals	0.0100	Bars
KiloPascals	0.01020	Kilograms per sq. cm
Liters	0.03532	Cubic feet
Liters	1000	Cubic centimeters
Liters	0.2642	Gallons
Liters per hour	0.004403	Gallons per minute
Meters	3.281	Feet
Meters	1.094	Yards
Meters	100.0	Centimeters
Meters	39.37	Inches
Pounds	0.1199	Gallons H ₂ O @ 60°F (U.S.)
Pounds	453.6	Grams
Pounds	0.0005	Short tons (2000 lbs.)
Pounds	0.4536	Kilograms
Pounds	0.0004536	Metric tons
Pounds	16.00	Ounces
Pounds per hour	6.323/M.W.	Cubic feet per minute
Pounds per hour	0.4536	Kilograms per hour
Pounds per hour liquid	0.002/Sp.Gr.	Gallons per minute liquid (at 60°F)
Pounds per sq. inch	27.68	Inches of water
Pounds per sq. inch	2.307	Feet of water
Pounds per sq. inch	2.036	Inches of mercury
Pounds per sq. inch	0.07031	Kilograms per sq. cm
Pounds per sq. inch	0.0680	Atmospheres
Pounds per sq. inch	51.71	Millimeters of mercury
Pounds per sq. inch	0.7032	Meters of water
Pounds per sq. inch	0.06895	Bar
Pounds per sq. inch	6.895	KiloPascals
Specific gravity (of gas or vapors)	28.97	Molecular weight (of gas or vapors)
Square centimeter	0.1550	Square inch
Square inch	6.4516	Square centimeter
Square inch	645.16	Square millimeter
SSU	0.2205 x SG	Centipoise
SSU	0.2162	Centistoke
Water (cubic feet)	62.4	Pounds (at 60°F)
Temperature:		
Centigrade	=	5/9 (Fahrenheit - 32)
Kelvin	=	Centigrade + 273
Fahrenheit	=	9/5 (Centigrade)+32
Fahrenheit +460°	=	Rankine
Fahrenheit (°F+460) 5/9	=	Kelvin

Air Capacities - Series JOS-E and JBS-E, Metric Units

Set Pressures 0.35 - 88 barg

Set Pressure (barg)	Orifice Letter Designation and Effective Area, sq.mm.															Set Pressure (kPa)
	D 71	E 126	F 198	G 325	H 506	J 830	K 1186	L 1841	M 2323	N 2800	P 4116	Q 7129	R 10323	T 16774	T2 17981	
1 bar incr.	0.8	1.5	2.4	4.0	6.3	10.3	14.8	23.0	29.0	35.0	51.5	89.2	129	209	225	100 kPa incr.
5 bar incr.	4.4	7.9	12.3	20.3	31.6	51.9	74.2	115	145	175	257	446	646	1049	1125	500 kPa incr.
0.35			3.4	5.6	8.8	14.5	20.7					124				35
0.40			3.6	5.9	9.2	15.1	21.6					129				40
0.45			3.7	6.1	9.5	15.6	22.3	34.7				134				45
0.50			3.8	6.3	9.8	16.1	23.1	35.8			80.2	139				50
0.55		2.5	3.9	6.5	10.1	16.6	23.8	37.0	46.6	56.2	82.7	143	207	337	361	55
0.60		2.6	4.0	6.7	10.4	17.1	24.5	38.0	48.0	57.9	85.1	147	213	347	372	60
0.65		2.6	4.2	6.9	10.7	17.6	25.2	39.1	49.4	59.5	87.6	151	219	357	382	65
0.70	1.5	2.7	4.3	7.0	11.0	18.1	25.9	40.2	50.7	61.1	89.9	155	225	366	392	70
0.75	1.5	2.8	4.4	7.2	11.3	18.6	26.5	41.2	52.0	62.7	92.2	159	231	376	403	75
0.80	1.6	2.9	4.5	7.4	11.6	19.0	27.2	42.3	53.3	64.3	94.6	163	237	385	413	80
0.85	1.6	2.9	4.6	7.6	11.9	19.5	27.9	43.3	54.7	65.9	96.9	167	243	395	423	85
0.90	1.7	3.0	4.7	7.8	12.2	20.0	28.6	44.4	56.0	67.5	99.3	172	249	404	433	90
0.95	1.7	3.1	4.8	8.0	12.5	20.5	29.2	45.4	57.3	69.1	101	176	254	414	444	95
1	1.7	3.1	5.0	8.1	12.7	20.9	29.9	46.5	58.6	70.7	104	180	260	423	454	100
2	2.6	4.6	7.2	11.8	18.5	30.4	43.4	67.4	85.1	102	150	261	378	614	658	200
4	4.3	7.7	12.2	19.9	31.1	51.1	73.0	113	143	172	253	439	635	1033	1107	400
6	6.1	10.9	17.1	28.1	43.8	71.9	102	159	201	242	356	617	894	1453	1557	600
8	7.9	14.1	22.1	36.2	56.5	92.7	132	205	259	312	459	796	1152	1873	2008	800
10	9.7	17.2	27.0	44.3	69.2	113	162	251	317	382	562	974	1411	2293	2458	1000
12	11.4	20.4	32.0	52.4	81.9	134	191	297	375	452	665	1153	1669	2713	2908	1200
14	13.2	23.6	36.9	60.6	94.5	155	221	343	433	522	768	1331	1928	3133	3358	1400
16	15.0	26.7	41.9	68.7	107	175	251	389	491	593	871	1510	2186	3552	3808	1600
18	16.8	29.9	46.9	76.8	119	196	280	435	550	663	974	1688	2444	3972	4258	1800
20	18.5	33.1	51.8	84.9	132	217	310	482	608	733	1077	1866	2703	4392	4709	2000
22	20.3	36.2	56.8	93.1	145	238	340	528	666	803	1180	2045		2200		
24	22.1	39.4	61.7	101	157	259	369	574	724	873	1284	2223				2400
26	23.9	42.6	66.7	109	170	279	399	620	782	943	1387	2402				2600
28	25.6	45.7	71.7	117	183	300	429	666	840	1013	1490	2580				2800
30	27.4	48.9	76.6	125	196	321	458	712	898	1083	1593	2759				3000
32	29.2	52.1	81.6	133	208	342	488	758	957	1153	1696	2937				3200
34	31.0	55.2	86.5	141	221	362	518	804	1015	1223	1799	3116				3400
36	32.7	58.4	91.5	149	234	383	548	850	1073	1294	1902	3294				3600
38	34.5	61.6	96.4	158	246	404	577	896	1131	1364	2005	3473				3800
40	36.3	64.7	101	166	259	425	607	942	1189	1434	2108	3651				4000
42	38.1	67.9	106	174	272	446	637	988	1247	1504	2211					4200
44	39.9	71.1	111	182	284	466	666	1034	1305	1574	2314					4400
46	41.6	74.2	116	190	297	487	696	1081	1364	1644	2417					4600
48	43.4	77.4	121	198	310	508	726	1127	1422	1714	2520					4800
50	45.2	80.6	126	206	322	529	755	1173	1480	1784	2623					5000
52	47.0	83.7	131	214	335	550	785	1219	1538	1854	2726					5200
54	48.7	86.9	136	223	348	570	815	1265	1596	1924	2829					5400
56	50.5	90.0	141	231	360	591	844	1311	1654	1995	2932					5600
58	52.3	93.2	146	239	373	612	874	1357	1713	2065	3035					5800
60	54.1	96.4	151	247	386	633	904	1403	1771	2135	3138					6000
62	55.8	99.5	155	255	398	653	933	1449	1829	2205	3241					6200
64	57.6	102	160	263	411	674	963	1495	1887	2275	3344					6400
66	59.4	105	165	271	424	695	993	1541	1945	2345	3448					6600
68	61.2	109	170	279	436	716	1023	1587	2003	2415	3551					6800
70	63.0	112	175	288	449	737	1052	1634	2061							7000
72	64.7	115	180	296	462	757	1082	1680	2120							7200
74	66.5	118	185	304	474	778	1112	1726	2178							7400
76	68.3	121	190	312	487	799	1141	1772								7600
78	70.1	124	195	320	500	820	1171	1818								7800
80	71.8	128	200	328	512	841	1201	1864								8000
82	73.6	131	205	336	525	861	1230	1910								8200
84	75.4	134	210	344	538	882	1260	1956								8400
86	77.2	137	215	353	551	903	1290	2002								8600
88	78.9	140	220	361	563	924	1319	2048								8800

Note

1. Capacities below 2.0 bar set pressure are calculated at 0.2 at bar overpressure.

Shaded values are JOS-E only.

Capacity in standard cubic meters of air at 16°C and 10% overpressure.¹ Valve discharging to atmospheric pressure.

Capacities certified by the National Board of Boiler and Pressure Vessel Inspectors and in accordance with the ASME Boiler and Pressure Vessel Code, Section VIII.

Air Capacities - Series JOS-E and JBS-E, Metric Units

Set Pressures 90 - 410 barg

Set Pressure (barg)	Orifice Letter Designation and Effective Area, sq.mm.															Set Pressure (kPag)
	D 71	E 126	F 198	G 325	H 506	J 830	K 1186	L 1841	M 2323	N 2800	P 4116	Q 7129	R 10323	T 16774	T2 17981	
1 bar incr.	0.8	1.5	2.4	4.0	6.3	10.3	14.8	23.0	29.0	35.0	51.5	89.2	129	209	225	100 kPa incr.
5 bar incr.	4.4	7.9	12.3	20.3	31.6	51.9	74.2	115	145	175	257	446	646	1049	1125	500 kPa incr.
90	80.7	143	225	369	576	944	1349	2094								9000
92	82.5	147	230	377	589	965	1379	2140								9200
94	84.3	150	235	385	601	986	1408	2186								9400
96	86.0	153	240	393	614	1007	1438	2233								9600
98	87.8	156	245	401	627	1028	1468	2279								9800
100	89.6	159	250	409	639	1048	1497	2325								10000
102	91.4	162	255	418	652	1069	1527	2371								10200
104	93.2	166	260	426	665	1090	1557									10400
106	94.9	169	265	434	677	1111	1587									10600
108	96.7	172	270	442	690	1132	1616									10800
110	98.5	175	275	450	703	1152	1646									11000
112	100	178	279	458	715	1173	1676									11200
114	102	181	284	466	728	1194	1705									11400
116	103	185	289	474	741	1215	1735									11600
118	105	188	294	483	753	1236	1765									11800
120	107	191	299	491	766	1256	1794									12000
122	109	194	304	499	779	1277	1824									12200
124	110	197	309	507	791	1298	1854									12400
126	112	200	314	515	804	1319	1883									12600
128	114	204	319	523	817	1339	1913									12800
130	116	207	324	531	829	1360	1943									13000
132	118	210	329	539	842	1381	1972									13200
134	119	213	334	548	855	1402	2002									13400
136	121	216	339	556	868	1423	2032									13600
138	123	219	344	564	880	1443	2062									13800
140	125	223	349	572	893	1464	2091									14000
142	126	226	354	580	906	1485	2121									14200
144	128	229	359	588	918	1506	2151									14400
146	130	232	364	596	931	1527	2180									14600
148	132	235	369	604	944	1547	2210									14800
150	134	238	374	613	956	1568	2240									15000
160	142	254	398	653	1020	1672										16000
170	151	270	423	694	1083	1776										17000
180	160	286	448	734	1146	1880										18000
190	169	302	473	775	1210											19000
200	178	318	498	816												20000
210	187	333	522	856												21000
220	196	349	547	897												22000
230	205	365	572	938												23000
240	214	381	597	978												24000
250	222	397	622	1019												25000
260	231	412	646													26000
270	240	428	671													27000
280	249	444	696													28000
290	258	460	721													29000
300	267	476	746													30000
310	276	492	770													31000
320	285	507	795													32000
330	293	523	820													33000
340	302	539	845													34000
350	311	555														35000
360	320	571														36000
370	329	587														37000
380	338	602														38000
390	347	618														39000
400	356	634														40000
410	365	650														41000

Capacity in standard cubic meters of air at 16°C and 10% overpressure. Valve discharging to atmospheric pressure.

Shaded values are JOS-E only.

Capacities certified by the National Board of Boiler and Pressure Vessel Inspectors and in accordance with the ASME Boiler and Pressure Vessel Code, Section VIII.

Water Capacities - Series JLT-JOS-E and JLT-JBS-E, Metric Units

Differential Pressures ΔP^1 , 1 - 80 bar²

Differential Pressure ΔP - psi	Orifice Letter Designation and Effective Area, sq.in.														Differential Pressure ΔP - kPa
	D 71	E 126	F 198	G 325	H 506	J 830	K 1186	L 1841	M 2323	N 2800	P 4116	Q 7129	R 10323	T 16774	
1	44.6	79.5	124	204	318	522	745	1157	1460	1760	2588	4482	6490	10547	100
2	63.1	112	176	288	450	738	1054	1636	2065	2489	3660	6339	9179	14916	200
3	77.2	137	215	353	551	904	1291	2004	2529	3049	4482	7764	11242	18268	300
4	89.2	159	249	408	636	1044	1491	2314	2920	3521	5176	8965	12981	21094	400
5	99.7	177	278	456	712	1167	1667	2587	3265	3936	5787	10023	14513	23584	500
6	109	194	305	499	780	1278	1826	2834	3577	4312	6339	10980	15898	25835	600
7	118	210	329	539	842	1381	1972	3062	3863	4658	6847	11859	17172	27905	700
8	126	224	352	577	900	1476	2108	3273	4130	4979	7320	12678	18358	29832	800
9	133	238	373	612	955	1566	2236	3472	4381	5281	7764	13447	19471	31641	900
10	141	251	393	645	1007	1651	2357	3659	4618	5567	8184	14175	20525	33353	1000
11	147	263	413	676	1056	1731	2472	3838	4843	5839	8583	14867	21527	34981	1100
12	154	275	431	706	1103	1808	2582	4009	5058	6098	8965	15528	22484	36536	1200
13	160	286	449	735	1148	1882	2688	4172	5265	6347	9331	16162	23402	38028	1300
14	166	297	465	763	1191	1953	2789	4330	5464	6587	9683	16772	24285	39464	1400
15	172	307	482	790	1233	2022	2887	4482	5656	6818	10023	17361	25138	40849	1500
16	178	318	498	816	1273	2088	2982	4629	5841	7042	10352	17930	25962	42189	1600
17	183	327	513	841	1312	2152	3074	4771	6021	7259	10671	18482	26761	43487	1700
18	189	337	528	865	1351	2215	3163	4910	6195	7469	10980	19018	27537	44748	1800
19	194	346	542	889	1388	2275	3250	5044	6365	7674	11281	19539	28292	45974	1900
20	199	355	556	912	1424	2334	3334	5175	6531	7873	11574	20046	29027	47169	2000
21	204	364	570	935	1459	2392	3416	5303	6692	8068	11860	20541	29743	48333	2100
22	209	372	584	957	1493	2448	3497	5428	6849	8257	12139	21025	30443	49471	2200
23	214	381	597	978	1527	2503	3575	5550	7003	8443	12412	21497	31128	50583	2300
24	218	389	610	999	1560	2557	3652	5669	7154	8625	12679	21960			2400
25	223	397	622	1020	1592	2610	3728	5786	7301	8802	12940	22413			2500
26	227	405	635	1040	1623	2662	3801	5901	7446	8977	13197	22856			2600
27	231	413	647	1060	1654	2712	3874	6013	7588	9148	13448	23292			2700
28	236	420	659	1079	1685	2762	3945	6124	7727	9316	13695	23719			2800
29	240	428	670	1098	1714	2811	4015	6232	7864	9481	13937	24139			2900
30	244	435	682	1117	1744	2859	4083	6339	7998	9643	14175	24552			3000
31	248	442	693	1136	1773	2906	4151	6443	8131	9802	14410	24958			3100
32	252	449	704	1154	1801	2953	4217	6547	8261	9959	14640	25357			3200
33	256	456	715	1172	1829	2999	4283	6648	8389	10113	14867	25750			3300
34	260	463	726	1189	1856	3044	4347	6748	8515	10265	15091	26137			3400
35	263	470	736	1207	1883	3088	4411	6847	8639	10415	15311	26519			3500
36	267	477	747	1224	1910	3132	4473	6944	8762	10563	15528	26895			3600
37	271	483	757	1241	1937	3175	4535	7039	8883	10709	15743	27266			3700
38	275	490	767	1257	1963	3218	4596	7134	9002	10853	15954	27632			3800
39	278	496	777	1274	1988	3260	4656	7227	9120	10994	16162	27993			3900
40	282	502	787	1290	2014	3302	4715	7319	9236	11134	16368	28350			4000
41	285	509	797	1306	2039	3343	4774	7410	9351	11273	16572	28702			4100
42	289	515	807	1322	2063	3383	4832	7500	9464	11409	16773	29050			4200
43	292	521	816	1338	2088	3423	4889	7589	9576	11544	16971	29394			4300
44	295	527	826	1353	2112	3463	4945	7677	9687	11678	17167	29734			4400
45	299	533	835	1368	2136	3502	5001	7763	9796	11810	17361				4500
46	302	539	844	1383	2159	3541	5057	7849	9904	11940	17553				4600
47	305	545	853	1398	2183	3579	5111	7934	10011	12070	17743				4700
48	309	550	862	1413	2206	3617	5165	8018	10117	12197	17931				4800
49	312	556	871	1428	2229	3654	5219	8101	10222	12324	18117				4900
50	315	562	880	1442	2251	3691	5272	8183	10326	12449	18300				5000
52	321	573	898	1471	2296	3764	5376	8345	10531	12695	18663				5200
54	327	584	915	1499	2340	3836	5479	8504	10731	12937	19018				5400
56	333	595	931	1526	2383	3906	5579	8660	10928	13175	19367				5600
58	339	605	948	1553	2425	3976	5678	8814	11122	13408	19710				5800
60	345	615	964	1580	2466	4044	5775	8964	11312	13637	20047				6000
62	351	626	980	1606	2507	4110	5870	9113	11499	13862	20379				6200
64	356	636	996	1632	2547	4176	5964	9258	11683	14084	20705				6400
66	362	645	1011	1657	2587	4241	6057	9402	11864	14303	21026				6600
68	367	655	1026	1682	2625	4305	6148	9543	12042	14518	21342				6800
70	373	665	1041	1707	2664	4368	6238	9683	12218	14730	21654				7000
72	378	674	1056	1731	2702	4430	6326	9820	12391	14939	21961				7200
74	383	683	1071	1755	2739	4491	6414	9956	12562	15145	22264				7400
76	389	693	1085	1778	2776	4551	6500	10089	12731						7600
78	394	702	1099	1802	2812	4610	6585	10221	12897						7800
80	399	711	1113	1825	2848	4669	6668	10351	13062						8000

Notes

1. Differential Pressure (ΔP) equals inlet pressure (set pressure plus overpressure) at flowing conditions minus back pressure.
2. See pages 18 to 47 for Minimum and Maximum Set Pressure Limits.

Capacity in liters per minute of water at 21°C and 10% overpressure.

Capacities certified by the National Board of Boiler and Pressure Vessel Inspectors and in accordance with the ASME Boiler and Pressure Vessel Code, Section VIII.

Water Capacities - Series JLT-JOS-E and JLT-JBS-E, Metric Units

Differential Pressures ΔP^1 , 82 - 455 bar²

Differential Pressure ΔP – psi	Orifice Letter Designation and Effective Area, sq.in.														Differential Pressure ΔP – kPa
	D 71	E 126	F 198	G 325	H 506	J 830	K 1186	L 1841	M 2323	N 2800	P 4116	Q 7129	R 10323	T 16774	
82	404	719	1127	1847	2883	4727	6751	10480	13224						8200
84	408	728	1141	1870	2918	4785	6833	10607	13384						8400
86	413	737	1154	1892	2953	4841	6914	10732							8600
88	418	745	1168	1914	2987	4897	6994	10857							8800
90	423	754	1181	1935	3021	4953	7073	10979							9000
92	428	762	1194	1957	3054	5007	7151	11101							9200
94	432	770	1207	1978	3087	5061	7228	11221							9400
96	437	779	1220	1999	3120	5115	7305	11339							9600
98	441	787	1232	2019	3152	5168	7381	11457							9800
100	446	795	1245	2040	3184	5220	7456	11573							10000
102	450	803	1257	2060	3216	5272	7530	11688							10200
104	455	810	1270	2080	3247	5324	7603	11802							10400
106	459	818	1282	2100	3278	5375	7676	11915							10600
108	463	826	1294	2120	3309	5425	7748	12027							10800
110	468	833	1306	2140	3339	5475	7820	12138							11000
112	472	841	1318	2159	3370	5525	7890	12248							11200
114	476	848	1329	2178	3400	5574	7960	12357							11400
116	480	856	1341	2197	3429	5623	8030								11600
118	484	863	1352	2216	3459	5671	8099								11800
120	488	870	1364	2235	3488	5719	8167								12000
122	492	878	1375	2253	3517	5766	8235								12200
124	496	885	1386	2272	3546	5813	8302								12400
126	500	892	1397	2290	3574	5860	8369								12600
128	504	899	1409	2308	3602	5906	8435								12800
130	508	906	1419	2326	3630	5952	8501								13000
132	512	913	1430	2344	3658	5998	8566								13200
134	516	920	1441	2362	3686	6043	8631								13400
136	520	927	1452	2379	3713	6088	8695								13600
138	524	934	1463	2397	3740	6133	8758								13800
140	527	940	1473	2414	3767	6177	8822								14000
142	531	947	1484	2431	3794	6221	8885								14200
144	535	954	1494	2448	3821	6265	8947								14400
146	539	960	1504	2465	3847	6308	9009								14600
148	542	967	1515	2482	3874	6351	9070								14800
150	546	973	1525	2499	3900	6394	9131								15000
160	564	1005	1575	2581	4028	6604	9431								16000
170	581	1036	1623	2660	4152	6807									17000
180	598	1066	1670	2737	4272	7004									18000
190	615	1095	1716	2812	4389	7196									19000
200	631	1124	1761	2885	4503	7383									20000
210	646	1152	1804	2956											21000
220	661	1179	1847	3026											22000
230	676	1205	1888	3094											23000
240	691	1231	1929	3161											24000
250	705	1257	1969	3226											25000
260	719	1282	2008	3290											26000
270	733	1306	2046	3352											27000
280	746	1330	2083	3414											28000
290	759	1354	2120												29000
300	772	1377	2157												30000
310	785	1399	2192												31000
320	798	1422	2227												32000
330	810	1444	2262												33000
340	822	1466	2296												34000
350	834	1487	2329												35000
360	846	1508	2362												36000
370	858	1529	2395												37000
380	869	1549													38000
390	881	1570													39000
400	892	1590													40000
410	903	1609													41000
420	914	1629													42000
430	925	1648													43000
440	936	1667													44000
450	946	1686													45000
455	951	1696													45500

Capacity in liters per minute of water at 21°C and 10% overpressure.

Capacities certified by the National Board of Boiler and Pressure Vessel Inspectors and in accordance with the ASME Boiler and Pressure Vessel Code, Section VIII.

Notes

- Differential Pressure (ΔP) equals inlet pressure (set pressure plus overpressure) at flowing conditions minus back pressure.
- See pages 18 to 47 for Minimum and Maximum Set Pressure Limits.

Saturated Steam Capacities, Unfired Pressure Vessel Service - Series JOS-E and JBS-E, Metric Units

Set Pressures 0.35 - 76 barg

Set Pressure (barg)	Orifice Letter Designation and Effective Area, sq.mm.															Set Pressure (kPag)
	D 71	E 126	F 198	G 325	H 506	J 830	K 1186	L 1841	M 2323	N 2800	P 4116	Q 7129	R 10323	T 16774	T2 17981	
1 bar incr. ²	3.9	7.1	11.1	18.2	28.5	46.7	66.7	103	130	157	231	401	581	944	1012	10 kPa incr.
5 bar incr. ²	19.9	35.6	55.7	91.3	142	233	333	518	654	788	1159	2007	2906	4723	5063	50 kPa incr.
0.35			155	255	398	652	932					5606				35
0.40			162	266	415	680	972					5843				40
0.45			168	275	430	705	1007	1563				6054				45
0.50			173	284	444	728	1040	1614				6254				50
0.55		114	179	293	458	751	1072	1665	2101	2533	3723	6449	9338	15174	16267	55
0.60		117	184	302	471	773	1104	1713	2162	2607	3832	6638	9611	15618	16743	60
0.65		121	189	310	485	795	1135	1762	2224	2681	3941	6827	9885	16063	17220	65
0.70	69.7	124	194	319	497	816	1165	1809	2283	2753	4047	7009	10149	16493	17680	70
0.75	71.5	127	199	327	510	837	1196	1856	2343	2824	4152	7192	10414	16922	18141	75
0.80	73.4	130	204	335	523	858	1226	1904	2402	2896	4257	7374	10678	17352	18601	80
0.85	75.2	134	209	344	536	880	1257	1951	2462	2968	4363	7557	10942	17781	19061	85
0.90	77.0	137	215	352	549	901	1287	1998	2521	3039	4468	7739	11206	18211	19522	90
0.95	78.8	140	220	360	562	922	1317	2045	2580	3111	4574	7922	11471	18640	19982	95
1	80.6	143	225	368	575	943	1348	2092	2640	3183	4679	8104	11735	19069	20442	100
2	117	208	326	535	835	1369	1955	3034	3829	4616	6786	11754	17020	27658	29649	200
3	156	279	437	716	1118	1833	2618	4065	5129	6183	9090	15744	22798	37046	39714	300
4	196	350	548	899	1403	2301	3286	5101	6437	7760	11408	19759	28611	46494	49841	400
5	236	421	660	1082	1688	2769	3954	6138	7745	9337	13727	23775	34425	55941	59969	500
6	276	492	772	1265	1974	3236	4622	7175	9053	10914	16045	27790	40239	65388	70096	600
7	316	564	883	1447	2259	3704	5290	8211	10361	12491	18363	31805	46052	74835	80224	700
8	356	635	995	1630	2544	4172	5958	9248	11669	14068	20681	35820	51866	84283	90351	800
9	396	706	1106	1813	2829	4639	6626	10285	12978	15645	23000	39835	57680	93730	100479	900
10	436	777	1218	1996	3115	5107	7293	11321	14286	17222	25318	43850	63494	103177	110606	1000
11	476	849	1329	2178	3400	5574	7961	12358	15594	18799	27636	47865	69307	112625	120734	1100
12	516	920	1441	2361	3685	6042	8629	13395	16902	20376	29954	51880	75121	122072	130861	1200
13	556	991	1552	2544	3970	6510	9297	14431	18210	21953	32272	55895	80935	131519	140989	1300
14	596	1062	1664	2727	4256	6977	9965	15468	19518	23530	34591	59910	86748	140966	151116	1400
15	636	1133	1776	2909	4541	7445	10633	16505	20826	25107	36909	63926	92562	150414	161244	1500
16	676	1205	1887	3092	4826	7913	11300	17541	22134	26684	39227	67941	98376	159861	171371	1600
17	716	1276	1999	3275	5111	8380	11968	18578	23442	28261	41545	71956	104190	169308	181499	1700
18	756	1347	2110	3458	5397	8848	12636	19615	24750	29838	43863	75971	110003	178756	191626	1800
19	796	1418	2222	3641	5682	9316	13304	20651	26058	31415	46182	79986	115817	188203	201754	1900
20	836	1489	2333	3823	5967	9783	13972	21688	27367	32992	48500	84001	121631	197650	211881	2000
22	916	1632	2556	4189	6538	10718	15308	23761	29983	36146	53136	92031				2200
24	996	1774	2780	4554	7108	11654	16643	25834	32599	39300	57773	100061				2400
26	1076	1917	3003	4920	7678	12589	17979	27908	35215	42454	62409	108092				2600
28	1155	2059	3226	5285	8249	13524	19315	29981	37831	45608	67046	116122				2800
30	1235	2202	3449	5651	8819	14460	20650	32054	40447	48762	71682	124152				3000
32	1315	2344	3672	6017	9390	15395	21986	34128	43064	51916	76319	132182				3200
34	1395	2487	3895	6382	9960	16330	23322	36201	45680	55070	80955	140212				3400
36	1475	2629	4118	6748	10531	17265	24657	38274	48296	58223	85591	148243				3600
38	1555	2771	4341	7113	11101	18201	25993	40348	50912	61377	90228	156273				3800
40	1635	2914	4564	7479	11672	19136	27329	42421	53528	64531	94864	164303				4000
42	1715	3056	4787	7844	12242	20071	28665	44494	56144	67685	99501					4200
44	1795	3199	5011	8210	12813	21007	30000	46568	58761	70839	104137					4400
46	1875	3341	5234	8575	13383	21942	31336	48641	61377	73993	108774					4600
48	1955	3484	5457	8941	13954	22877	32672	50714	63993	77147	113410					4800
50	2035	3626	5680	9306	14524	23812	34007	52788	66609	80301	118046					5000
52	2115	3768	5903	9672	15095	24748	35343	54861	69225	83455	122683					5200
54	2195	3911	6126	10037	15665	25683	36679	56934	71841	86609	127319					5400
56	2275	4053	6349	10403	16236	26618	38014	59008	74458	89763	131956					5600
58	2355	4196	6572	10768	16806	27554	39350	61081	77074	92917	136592					5800
60	2434	4338	6795	11134	17376	28489	40686	63154	79690	96071	141229					6000
62	2514	4481	7018	11500	17947	29424	42022	65227	82306	99225	145865					6200
64	2594	4623	7242	11865	18517	30359	43357	67301	84922	102379	150502					6400
66	2674	4766	7465	12231	19088	31295	44693	69374	87538	105533	155138					6600
68	2754	4908	7688	12596	19658	32230	46029	71447	90155	108687	159774					6800
70	2834	5050	7911	12962	20229	33165	47364	73521	92771							7000
72	2914	5193	8134	13327	20799	34101	48700	75594	95387							7200
74	2994	5335	8357	13693	21370	35036	50036	77667	98003							7400
76	3074	5478	8580	14058	21940	35971	51372	79741								7600

Notes

- Capacities below 2.0 bar set pressure are calculated at 0.2 at bar overpressure.
- Not valid below 2.0 bar set pressure.

Shaded values are JOS-E only.

Capacity in kilograms per hour of steam at 10% overpressure.¹ Valve discharging to atmospheric pressure.

Capacities certified by the National Board of Boiler and Pressure Vessel Inspectors and in accordance with the ASME Boiler and Pressure Vessel Code, Section VIII.

**Saturated Steam Capacities, Unfired Pressure Vessel Service - Series JOS-E and JBS-E, Metric Units
Set Pressures 78 - 200 barg**

Set Pressure (barg)	Orifice Letter Designation and Effective Area, sq.mm.															Set Pressure (kPag)
	D 71	E 126	F 198	G 325	H 506	J 830	K 1186	L 1841	M 2323	N 2800	P 4116	Q 7129	R 10323	T 16774	T2 17981	
1 bar incr. ²	3.9	7.1	11.1	18.2	28.5	46.7	66.7	103	130	157	231	401	581	944	1012	10 kPa incr.
5 bar incr. ²	19.9	35.6	55.7	91.3	142	233	333	518	654	788	1159	2007	2906	4723	5063	50 kPa incr.
78	3154	5620	8803	14424	22511	36906	52707	81814								7800
80	3234	5763	9026	14789	23081	37842	54043	83887								8000
82	3314	5905	9249	15155	23652	38777	55379	85961								8200
84	3394	6047	9473	15520	24222	39712	56714	88034								8400
86	3474	6190	9696	15886	24793	40647	58050	90107								8600
88	3554	6332	9919	16252	25363	41583	59386	92181								8800
90	3634	6475	10142	16617	25934	42518	60721	94254								9000
92	3714	6617	10365	16983	26504	43453	62057	96327								9200
94	3780	6736	10550	17286	26978	44230	63167	98050								9400
96	3866	6889	10791	17681	27593	45240	64608	100287								9600
98	3953	7044	11033	18077	28212	46254	66056	102535								9800
100	4040	7199	11276	18475	28834	47273	67512	104794								10000
102	4127	7355	11520	18876	29458	48297	68975	107065								10200
104	4215	7512	11766	19278	30086	49327	70445									10400
106	4304	7669	12013	19683	30718	50362	71923									10600
108	4393	7828	12261	20089	31353	51402	73410									10800
110	4482	7987	12511	20498	31991	52449	74904									11000
112	4572	8147	12762	20910	32633	53502	76408									11200
114	4663	8309	13015	21324	33279	54561	77920									11400
116	4754	8471	13269	21740	33929	55626	79442									11600
118	4846	8634	13524	22159	34583	56698	80973									11800
120	4938	8799	13782	22581	35241	57778	82514									12000
122	5031	8964	14041	23006	35904	58864	84065									12200
124	5124	9131	14302	23433	36571	59958	85628									12400
126	5218	9298	14565	23864	37243	61059	87201									12600
128	5313	9467	14829	24297	37919	62169	88785									12800
130	5409	9638	15096	24734	38601	63287	90382									13000
132	5505	9809	15365	25175	39289	64414	91991									13200
134	5602	9982	15636	25618	39981	65549										13400
136	5700	10157	15909	26066	40680	66694										13600
138	5799	10332	16184	26517	41384	67849										13800
140	5898	10510	16462	26972	42094	69013										14000
142	5999	10689	16742	27432	42811	70189										14200
144	6100	10869	17025	27895	43535	71375										14400
146	6202	11052	17311	28363	44265	72572										14600
148	6306	11236	17599	28836	45003	73782										14800
150	6410	11422	17891	29314	45748	75004										15000
152	6516	11610	18186	29796	46501	76239										15200
154	6622	11800	18483	30284	47263	77487										15400
156	6730	11992	18784	30777	48033	78749										15600
158	6839	12187	19089	31277	48812	80027										15800
160	6950	12384	19397	31782	49600	81319										16000
162	7062	12583	19710	32293	50399	82628										16200
164	7175	12785	20026	32812	51207	83954										16400
166	7290	12990	20346	33337	52027	85298										16600
168	7406	13197	20671	33869	52858	86660										16800
170	7525	13408	21001	34409	53701											17000
172	7644	13621	21336	34957												17200
174	7766	13838	21675	35514												17400
176	7890	14059	22021	36080												17600
178	8016	14283	22372	36655												17800
180	8143	14511	22728	37239												18000
182	8274	14743	23092	37835												18200
184	8406	14979	23462	38441												18400
186	8541	15220	23839	39059												18600
188	8679	15465	24224	39690												18800
190	8820	15716	24617	40334												19000
192	8964	15973	25018	40991												19200
196	9262	16503	25849	42352												19600
200	9574	17059	26721	43781												20000

Capacity in kilograms per hour of steam at 10% overpressure. Valve discharging to atmospheric pressure.

Capacities certified by the National Board of Boiler and Pressure Vessel Inspectors and in accordance with the ASME Boiler and Pressure Vessel Code, Section VIII.

Crosby BlockBody™ Pressure Relief Valves

Many modern day process systems requiring overpressure protection involve significantly larger relief requirements and set pressures that exceed the maximum limits as shown in API Standard 526 for pressure relief valves. For these applications, the most common solution has been to design the relief system with multiple, smaller orifice pressure relief valves that can be set within the limitations of API Standard 526.

The use of API Standard 526 valves can add significant cost to the relief system since multiple pressure relief valves result in increased weight as well as added inlet and discharge piping costs.

Crosby Series JOS-E-BLK, JBS-E-BLK, BlockBody™ Pressure Relief Valves provide a cost-effective alternative to multiple high pressure, smaller orifice valves.

BlockBody pressure relief valves provide greater capacity and can be set at pressures significantly higher than the traditional design, cast steel API Standard 526 relief valves. These valves are ideal for high pressure applications since multiple high pressure, small orifice valves can be replaced by fewer or in some cases, a single BlockBody valve.

The BlockBody design also adds significantly to the scope of materials that can be provided in accordance with ASME Code Section VIII by adding a wide array of wrought materials. By utilizing the BlockBody design, higher material integrity is offered which can minimize non-destructive examination (NDE) requirements.

BlockBody Relief Valves can be designed to unconventional sizes. This can be an advantage when retrofitting to existing systems. Pressure relief valve



outlet sizes can be increased beyond API standards to eliminate outlet piping reducers and mitigate built-up back pressure in the downstream piping.

Features

Geometrically Designed Body and Bonnet

- Eliminates the need for specifying multiple, smaller orifice cast steel API Standard 526 pressure relief valves. One single block body installation has satisfied the capacity of twelve API Standard 526 valves.
- BlockBody design provides significant weight reduction when compared to multiple smaller orifice PRVs.
- Inlet and discharge piping costs can be significantly reduced.
- Less downtime and maintenance
- Fewer spare parts required

Availability of Specific Inlet/Outlet Flange Configurations and Combinations

- Unique center-to-face dimensions to meet existing system dimensions.

Forged Body Standard Construction

Increases spectrum of materials available for harsh service or corrosive service applications.

- Availability of state-of-art metallurgy.
- Suitable for backpressure applications considerably beyond CI 300 service.

Large Installed Base

- Reliable and field proven design.

BlockBody™ Design

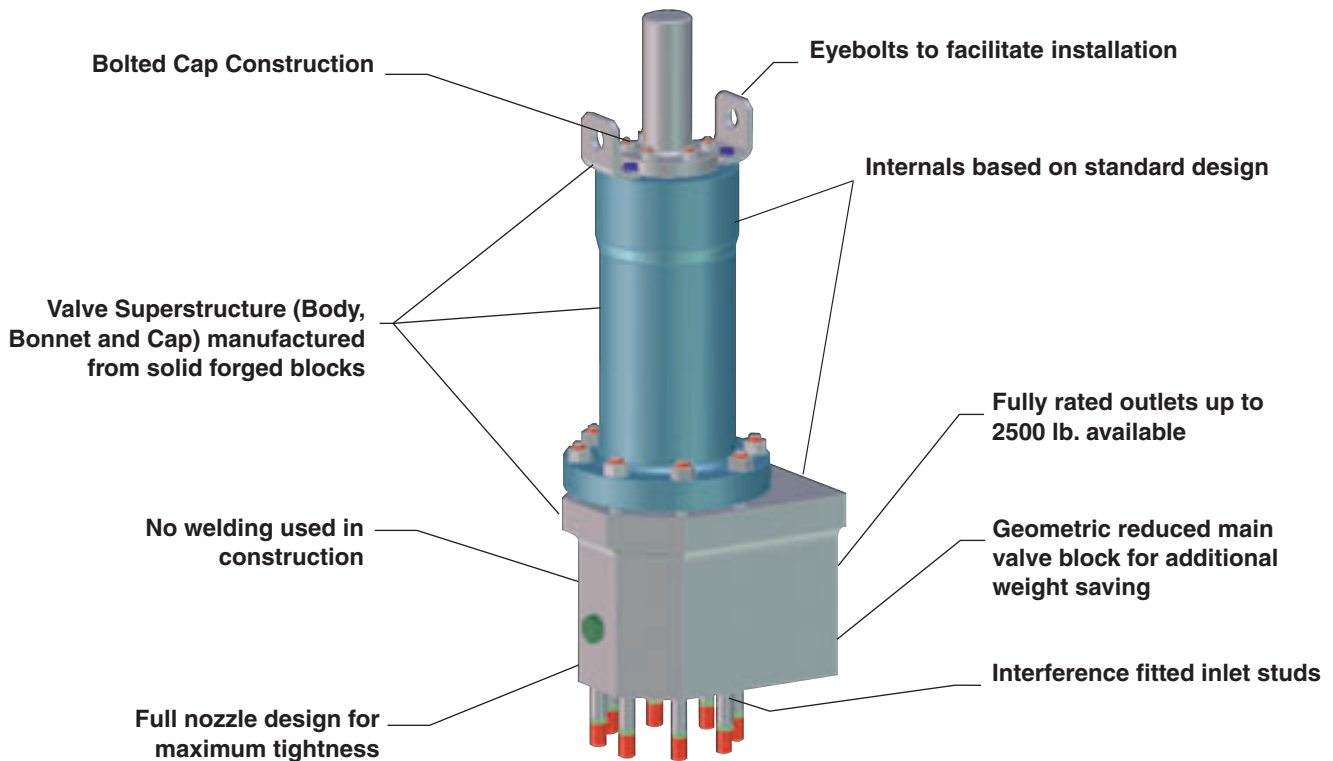

Series JBS-E-BLK

Typical Materials of Construction and Configurations

Body, Bonnet and Cap:

- ASME SA105 Carbon Steel
- ASME SA182 Grade F5a Alloy Steel
- ASME SA182 Grade F9 Alloy Steel
- ASME SA479 Type 316 Stainless Steel
- ASME SB348 Grade 7 Titanium
- ASME SA182 Grade F51 Duplex Stainless Steel
- ASME SA479 UNS-S32550 Super Duplex Stainless Steel
- ASME SA350 Grade LF2 Carbon Steel
- ASTM B348 Grade 4 Titanium

Trim:

- ASME SA479 Type 316 Stainless Steel
- ASME SB425 UNS N08825 Incoloy 825
- ASME SB446 UNS N06625 Inconel 625
- ASME SA479 UNS S31803 Duplex Stainless Steel
- ASTM B348 Grade 4 Titanium

Spring:

- High Temperature Alloy Steel
- Titanium
- Inconel® X-750
- Chrome Steel

- Type 316 Stainless Steel
- Hastelloy® B
- Hastelloy® C
- Monel®
- Alloy 20

Optional Construction:

- O-ring soft seat
- Special coating systems
- Steam purge
- Supplementary back pressure balancing piston

Connections:

- Ring type joint inlet/outlet
- API 6BX 10,000# inlet
- Grayloc®
- Techlok®

Notes

1. Grayloc® is a registered trademark of Grayloc Products, L.L.C.
2. Techlok® is a registered trademark of (waiting to hear from Vector International.)

Crosby Series JBS-BP-E and JLT-JBS-BP-E balanced bellows valves with supplementary back pressure balancing piston

Series JBS-BP-E and JLT-JBS-BP-E are a modification to the Crosby bellows pressure relief valve designed and tested in collaboration with engineers of one of the world's leading petroleum companies. This adaptation provides additional assurance of safe performance in the event of bellows failure on installations having discharge manifold systems where back pressures (constant or variable) are present. The Crosby bellows pressure relief valve (Series JBS-E and JLT-JBS-E) was especially developed for service under back pressure conditions. The balanced area bellows counteracts back pressure effects. However, in case of a broken or ruptured bellows, the valve would perform in the manner of a standard valve without bellows. Introduction of the Supplementary Back Pressure Balancing Piston guarantees full performance characteristics of the valve until necessary replacement of the bellows can be made. This design, illustrated at the right, thus affords double protection.

Unless compensated for, the effects of back pressure may cause (1) a change in the opening pressure, (2) a decrease in valve capacity, and (3) valve performance to become unstable at higher back pressure. Use of the bellows valve with supplementary balancing piston maintains the balancing effect even after bellows failure and in such event would allow the valve to function in essentially the same manner as with the bellows intact. However, the bonnet of the valve must be vented in order to insure proper functioning of the valve. The vent also serves for a tell-tale in case of a ruptured or broken bellows.

Design

The auxiliary balancing piston is incorporated in the basic bellows valve, modified to include the piston (5B) and the cylinder (17) which is part of the disc holder. The guiding clearances are held to a minimum and, in addition, grooves in the piston form a labyrinth seal to reduce flow between the piston and cylinder. Thus, in the event of a bellows failure, the leakage of fluid to atmosphere is kept to a minimum.

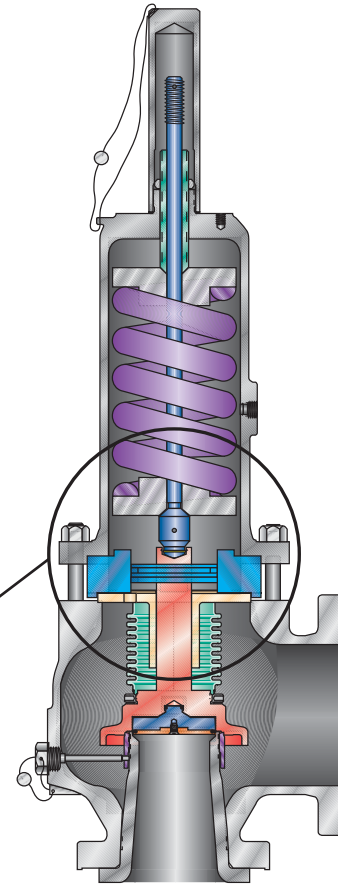

Crosby Style JB Large Orifice Pressure Relief Valves

For larger flow applications that cannot be satisfied by traditional API Standard 526 pressure relief valves, Crosby offers a wide scope of large orifice relief valves available in 10 x 14 through 20 x 24 configurations. Refer to Catalog CROMC-0290-US for further information.

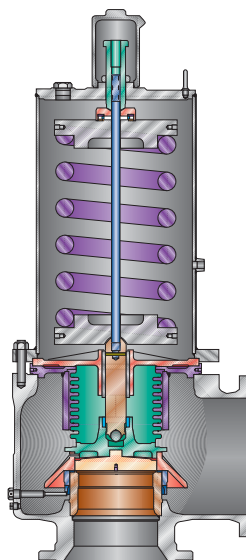

Ordering Information

The primary purpose of Series JOS-E/JBS-E/JLT-E pressure relief valves is to protect lives and property. In order to select the proper valve for your application, please provide the information listed below. Details of the process fluid and conditions are especially important. If there is any doubt as to selection or application of valves or parts, please contact your local Crosby Sales Office or Representative.

Ordering Information	Example
Quantity	5
Nominal valve size (inlet x orifice x outlet)	4 x L x 6
Valve series	JOS-E-45
Inlet connection rating and facing	600 RF
Outlet connection rating and facing	150 RF
Service (liquid, gas or vapor)	Air
Set pressure (psig)	800 psig
Back pressure (psig) if any, and whether constant or variable	Atmosphere
Maximum service temperature (°F)	Ambient 60°F
Cap or lifting lever type	Type C
Valve materials	Standard
Seat material	Metal-to-metal standard
Code requirements	ASME Unfired Pressure Vessel Code, Section VIII
Required capacity	45433 SCFM
Accumulation (allowable overpressure)	10%
Molecular weight - vapor	-
Specific gravity - gases and liquids	1.0
Viscosity - liquids	-

How to Order

Examples:

(1) To specify a G orifice (0.503 sq.in.) [325 sq.mm] Style JOS conventional valve with standard materials for liquid service at 700 psig [48.2 barg] and at +700°F [+371°C] with a packed lifting lever, the following designation applies:

1^{1/2} G 2^{1/2} JLT-JOS-E-46-D

(2) To specify an M orifice (3.60 sq.in.) [2323 sq.mm] Style JBS bellows valve with back pressure balancing piston, Monel nozzle and disc insert, and Kalrez O-ring soft seats for gas service at 200 psig [13.7 barg] and +400°F [+204°C] with threaded cap and test rod, the following designation applies:

4M6 JBS-BP-E-25-M1-K with Kalrez

(3) To specify a K orifice (1.838 sq.in.) [1186 sq.mm] Style JOS conventional valve with open bonnet and standard materials for ASME Code Section VIII steam service at 600 psig [41.3 barg] and +600°F [+316°C] with a regular lifting lever, the following designation applies:

3K4 JOS-H-E-45-C

Parts

To order parts, the following information should be included:

- Quantity
- Part name, i.e., disc insert
- Size, series and valve number
- Assembly number (from valve nameplate) or shop number
- Serial number (from valve nameplate)
- Original purchase order number (if assembly number has been destroyed).

				CERTIFIED BY CROSBY, STAFFORD, TX			
SIZE STYLE ID2 JOS-E-15-J							
SHOP NO. 61300	SET PRESS. PSI 100	CDTF PSI 91					
SER. NO. VA0001234	BACK PRESS. PSI 10	TC PSI 1					
CAP 245 SCFM AT 60F			OVER PRESS. 10%				

Sample Nameplate

(Figures shown are for illustrative purposes only.)

Crosby provides special "fast response" delivery service of spare parts to satisfy unplanned parts requirements. Fast response delivery service can be initiated by contacting your local Crosby representative. Emergency delivery service is available direct from the factory, 24 hours a day, 7 days a week by calling 281-274-4400.

Springs with Washers

To order springs with washers, in addition to the other information included for "Parts", the required valve set pressure must also be specified. If the spring is for a nonbellows valve, and there is a constant back pressure condition, that too should be specified. Also specify spring material and coating if other than standard.

Replacement Valves

To replace a valve in service, the shop number or assembly number, serial number, set pressure and previous order number should be specified.

Tyco Valves & Controls

www.tycovalves.com

Tyco Flow Control (TFC) provides the information herein in good faith but makes no representation as to its comprehensiveness or accuracy. This data sheet is intended only as a guide to TFC products and services. Individuals using this data sheet must exercise their independent judgment in evaluating product selection and determining product appropriateness for their particular purpose and system requirements. TFC MAKES NO REPRESENTATIONS OR WARRANTIES, EITHER EXPRESS OR IMPLIED, INCLUDING WITHOUT LIMITATION ANY WARRANTIES OF MERCHANTABILITY OR FITNESS FOR A PARTICULAR PURPOSE WITH RESPECT TO THE INFORMATION SET FORTH HEREIN OR THE PRODUCT(S) TO WHICH THE INFORMATION REFERS. ACCORDINGLY, TFC WILL NOT BE RESPONSIBLE FOR DAMAGES (OF ANY KIND OR NATURE, INCLUDING INCIDENTAL, INDIRECT, OR CONSEQUENTIAL DAMAGES) RESULTING FROM THE USE OF OR RELIANCE UPON THIS INFORMATION. Patents and Patents Pending in the U.S. and foreign countries. Tyco reserves the right to change product designs and specifications without notice.