



DK32 - DK34 - DK37 Technical Datasheet

Variable area flowmeter

- Robust construction for extreme operating conditions
- Local indication without auxiliary power
- High pressure and temperature durability



1	Product features	3
1.1	Flowmeter solutions in an all-metal design.....	3
1.2	Variable-area flowmeters of the type DK metal.....	4
1.3	Operating principle.....	6
2	Technical data	7
2.1	Technical data.....	7
2.2	Dimensions.....	11
2.3	Flow table.....	14
2.4	Differential pressure regulators.....	16
3	Installation	19
3.1	Intended use.....	19
3.2	Installation requirements.....	19
4	Electrical connections	20
4.1	Electrical connection of limit switches.....	20
4.2	DK37/M8M limit switches.....	21
4.3	DK37/M8E electrical signal output.....	22
4.3.1	Power supply.....	23
4.3.2	Load for HART® communication.....	23
4.3.3	Parametrization.....	23
5	Order form	24
6	Notes	25

1.1 Flowmeter solutions in an all-metal design

Solid metal DK flowmeters are suitable for measuring the flow rate of liquids, gases and vapors. Because of their robust design the flowmeters are particularly suited for difficult operating and environmental conditions.

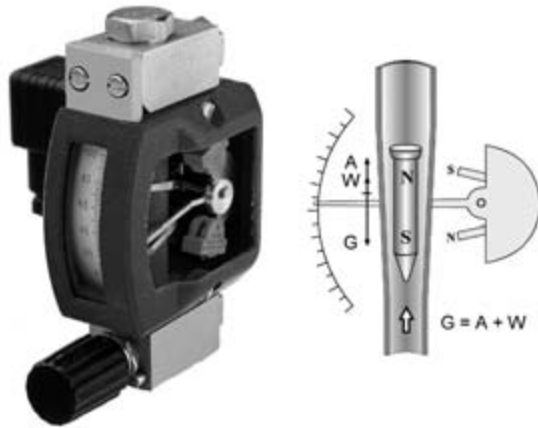

Highlights

- DK32 with horizontal connections - with valve
- DK34 with vertical connections - without valve
- DK37 with an increased measurement accuracy and larger indication
- Narrow design enabling a high packing density
- Simple installation and start-up

Industries

- Chemical
- Heating, cooling, and air conditioning
- Iron, Steel & Metal
- Electronics
- Oil & Gas
- Petrochemistry
- Power plants
- Mechanical engineering
- Paper & Pulp
- Water

Applications

- Fine metering
- Gas chromatography
- Minimum level monitoring and control
- In conjunction with a differential pressure regulator: Ensures constant flow rate in the case of variable inlet or outlet pressures

1.2 Variable-area flowmeters of the type DK metal

DK32



- Max. two limit switches (NAMUR) or floating reed contact
- Horizontal process connections
- For flow rates of 0.15 l/h and greater (water) and 1.6 l/h (air)
- Option with valve on top or without valve

DK34



- Max. two limit switches (NAMUR) or floating reed contact
- Vertical process connections
- For flow rates of 0.15 l/h and greater (water) and 1.6 l/h (air)

DK32 with inlet pressure regulators



Inlet or outlet pressure regulators are used to provide constant flow rates in the case of variable inlet or outlet pressures.

DK37/M8E

- Electronical bargraph indication
- 4...20 mA current output and HART® communication
- For flow rates of 0.15 l/h and greater (water) and 1.6 l/h (air)
- Option with valve on top or without valve

DK37/M8M

- Max. two limit switches (NAMUR)
- Horizontal process connection
- For flow rates of 0.15 l/h and greater (water) and 1.6 l/h (air)
- Option with valve on top or without valve

DK37 with inlet pressure regulators

Inlet or outlet pressure regulators are used to provide constant flow rates in the case of variable inlet or outlet pressures.

1.3 Operating principle

The flowmeter operates on the float measuring principle.

The measuring section consists of a metal cone in which a float can move freely up and down. The medium flows through the flowmeter from bottom to top.

The float adjusts itself so that the buoyancy force A acting on it, the form drag W and its weight G are in equilibrium: $G = A + W$.

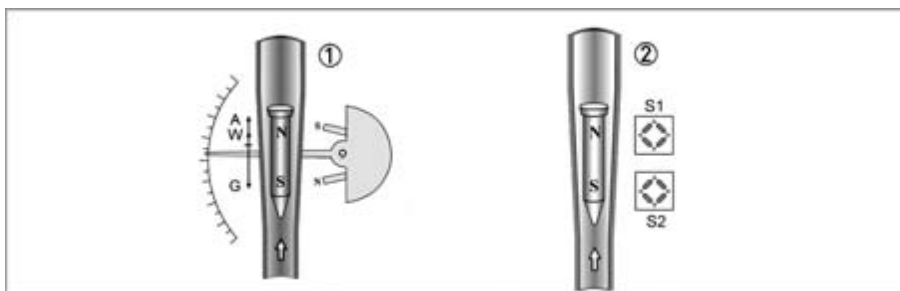

Figure 1-1: Operating principle

For the DK32, DK34 and DK37/M8M ① the flow-dependent height of the float in the measuring section is transmitted by means of a magnetic coupling and displayed on a scale.

For the DK37/M8E ② the flow-dependent height of the float in the measuring section is transmitted to the electronic display by means of a magnetic coupling on sensors S1 and S2.

2.1 Technical data

- *The following data is provided for general applications. If you require data that is more relevant to your specific application, please contact us or your local representative.*
- *Additional information (certificates, special tools, software,...) and complete product documentation can be downloaded free of charge from the website (Download Center).*

Measuring system

Application range	Flow measurement of liquids, gases and vapors
Operating method / measuring principle	Float measuring principle
Measured value	
Primary measured value	Float position
Secondary measured value	Operating and standard volumetric flow

Measuring accuracy

Directive	VDI / VDE Code 3513 Sheet 2 (q _G =50%)
DK32 DK34	4.0%
DK37	2.5%

Operating conditions

Max. operating temperature TS	-80..+200°C / -112...+392°F
Operating pressure PS	Pressure Equipment Directive 97/23/EC
Test pressure PT	Pressure Equipment Directive 97/23/EC and AD 2000-HP30
Max. allowable operating pressure PS	130 bar standard ①

Protection category

DK32 / DK34 without cable glands	IP66 and IP68
DK32 / DK34 with cable glands	IP65
DK37	IP66

Installation conditions

Inlet / outlet run	non
--------------------	-----

① higher pressures on request

Materials

Head piece, foot piece, cone	CrNi steel 1.4404 / 316 L
upper plug	CrNi steel 1.4404 / 316 L
Standard float	CrNi steel 1.4404 / 316 L or titanium
Metering unit	CrNi steel 1.4571 / 316 Ti
Valve spindle	CrNi steel 1.4404 / 316 L
Valve plug gasket	FPM ①
Metering unit gasket	FPM and PTFE ①
Indicator housing DK32 34	Die-cast Aluminium, coated
Indicator housing DK37	PPS

① other gasket materials on request

Temperatures

Max. process temperature at $T_{amb.} < 40^{\circ}\text{C} / 104^{\circ}\text{F}$	[°C]	[°F]
DK32 with valve	-40...+150 ①	-40...+302 ①
DK34 without valve	-80...+150 ①	-112...+302 ①
DK32 DK34 with limit switches	-25/-40...+145	-13/-40...+293
DK37M8M without valve	-80...+150 ①	-112...+302 ①
DK37M8M with valve	-40...+150 ①	-40...+302 ①
DK37/M8M with limit switches	-25/-40...+150	13/-40...+302
DK37M8E with electronical indicator	-25...+135	-13...+275
Max. ambient temperature $T_{amb.}$	-25...+70	-13...+158

① High temperature version up to 200°C / 392°F

Indicators of DK32 DK34 DK37/M8M with limit switches

DK32 - 34 /K./S DK37M8M	Cable fitting	M16 x 1,5		
	Clamp terminal	1,5mm ²		
DK32 - 34 /K./S	Clamping range	4,5... 10mm		
DK37M8M	Clamping range	3...7mm		
DK32 - 34/K./L	∅ Connecting cable	approx. 7mm		
	Cable length	approx. 1.7m (other length on request)		
Limit switch	SC2-N0 I7S2002-N	SJ2-SN ①	SJ2-S1N ①	
Type NAMUR	2-wire	2-wire	2-wire	
Switch element function	Normally closed	Normally closed	Normally open	
Nominal voltage U ₀	8VDC	8VDC	8VDC	
Pointer shaft not read	≥3mA	≥3mA	≤1mA	
Pointer shaft read	≤1mA	≤1mA	≥3mA	
DK32 DK34 with reed contact	Switching type	bistable		
	Switching reproducibility	<5% of full scale value		
	Breaking capacity	12VA ②		
	Max. supply voltage	30VDC ②		
	Max. current	0,5A ②		

① safety oriented

② reduced values for Ex version

Indicator DK37/M8E

Cable fitting	M16 x 1.5	
Cable diameter	8...10mm	
Clamp connection	M8M/K - 1,5mm ²	M8E - 2,5mm ²
Measurement signal	4...20mA for 0...100% flow value, two-wire technology	
Power supply	14.8...30VDC	
Min. power supply for HART™	20.5VDC	
Effect of supply power	<0.1%	
External resistance dependency	<0.1%	
Effect of temperature	<10µA/K	
Max. external resistance / load impedance	640 Ohm (30VDC)	
Min. load for HART®	250 Ohm	
Software- firmware version	01.15	
Ident No.	3204090400	

M8E HART® parameter configuration

Name of manufacturer (code)	KROHNE Messtechnik (69)
Name of model	M8E (230)
HART® protocol revision	5.1
Device revision	1
Physical layer	FSK
Device category	Transmitter

M8E process variable

M8E process variable flow	Values [%]	Signal output [mA]
Over range	+102,5 (±1%)	20,24...20,56
Device error detection	>106,25	≥21,00
Maximum	112,5	22
Multi-drop operation	-	4,5
Min. U _{ext.}	14,8VDC	

Approvals

Standard	Indicator	Designation
ATEX	DK32 DK34 mechanical	II2GD IIC II3GD IIC
	DK32 DK34 electrical	II2G Ex ia IIC T6
	DK37 mechanical	II2GD IIC II3GD IIC
	DK37 electrical	II2G Ex ia IIC T6
IEC Ex	DK32 DK34 electrical	Ex ia IIC T6
FM	DK32 DK34	IS/I/1/ABCD;T6 NI/I/2/ABCD;T6 S/II, III/2/FG;T6 IS/I, II, III/1/A-G NI/II/2/ABCD
Nepsi	DK32 DK34	Ex nA II T1-T6
	DK37	Ex ia IIC T1-T6

2.2 Dimensions

Dimensions, DK32 DK34

	Device	a		b		c		d	
		[mm]	["']	[mm]	["']	[mm]	["']	[mm]	["']
①	DK32 with valve and horizontal process connections	42	1,66	118	4,65	90	3,55	100	3,94
②	DK34 without valve and vertical process connections	42	1,66	110	4,33	-	-	75	3,07
③	DK32 DK34 with limit switches K1/K2	46	1,81	approx. 90	ca. 3,55	1500	50,1	approx. 50	ca. 1,97
④	DK32 with flange connections	-	-	250	10,2	90	3,55	approx. 195	ca. 7,68

DK32

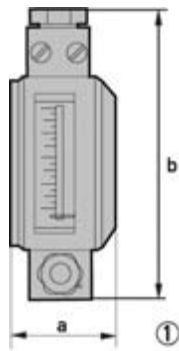

DK32

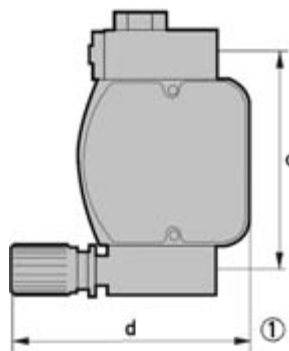

DK34

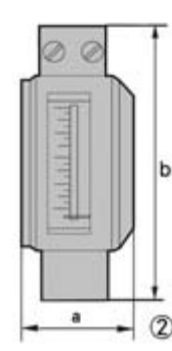

DK34

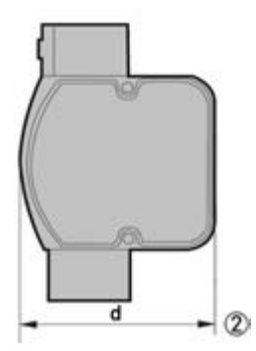

DK32 (DK34) with K1/K2

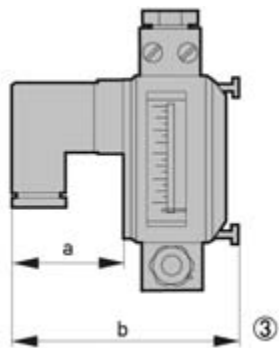

DK32 (DK34) with K1/K2

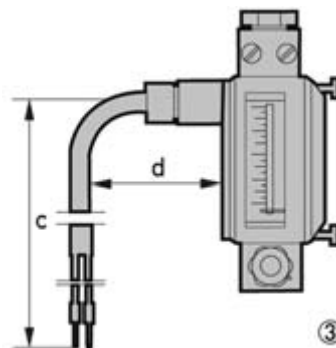

DK32 with flange connections

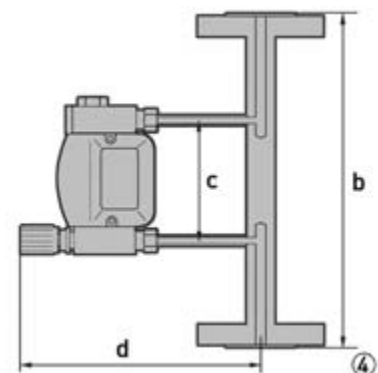

DK37 dimensions

		a		b		c		d approx.	
	Device	[mm]	["]	[mm]	["]	[mm]	["]	[mm]	["]
①	DK37/M8E with valve and horizontal process connections	56	2,21	153	6,03	125	4,92	144	ca. 5,67
②	DK37/M8E with valve on top	56	2,21	183	7,21	155	6,11	144	ca. 5,67
③	DK37/M8M/K . with valve and horizontal process connections	56	2,21	153	6,03	125	4,92	160	ca. 6,15
④	DK37/M8M/K . without valve and vertical process connections	56	2,21	145	5,71	145	5,71	144	ca. 5,52
⑤	DK37/M8E without valve and vertical process connections	56	2,21	145	5,71	145	5,71	121	ca. 4,77

DK37/M8M with valve

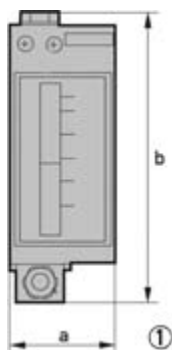

DK37/M8E with valve

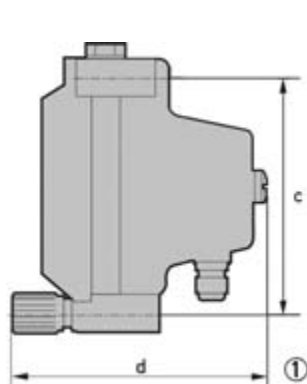

DK37/M8E with valve on top

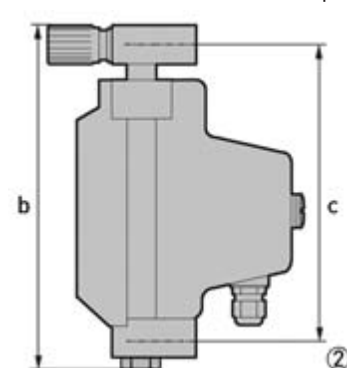

DK37/M8M with K1/K2

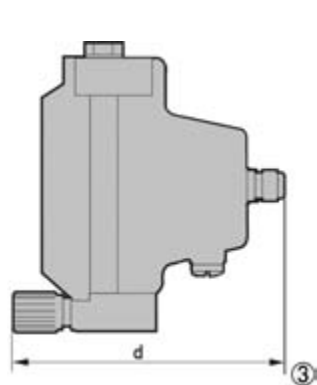

DK37/M8M without valve and vertical connections

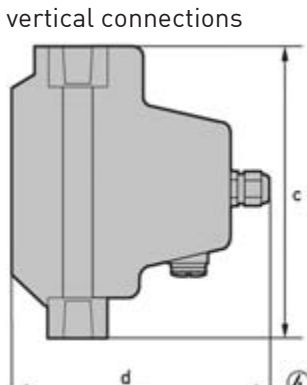

DK37/M8E without valve and vertical connections

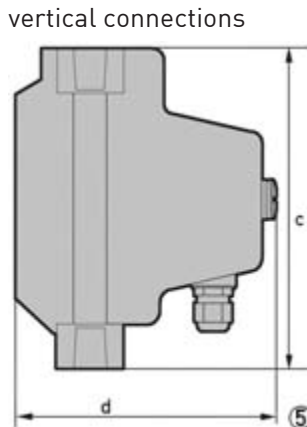

Min. installation distance

If several instruments are installed side by side, a minimum distance between these instruments is required.

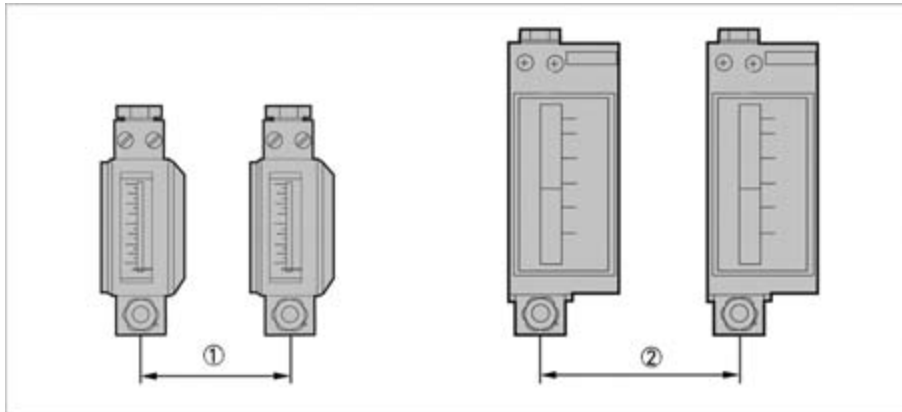

Min. distance

	Device	[mm]	[""]
①	DK32 / DK34	60	2,36
②	DK37/M8M	100	3,94
②	DK37/M8E	120	4,73

Weights

	Approx. weights [g]	ca. [lb]
DK32	700	1,54
DK34	600	1,32
DK37/M8M	800	1,76
DK37/M8E	1000	2,21
DK32 with differential pressure regulators	2500	5,51
DK37/M8E with differential pressure regulators	2800	6,18
DK37/M8M with differential pressure regulators	2600	5,73

Connections

Standard	1/4" NPT inside thread
	G 1/4, Ermeto, Serto, Dilo, Gyrolok, Swagelok, flanges ①

① other connections on request

2.3 Flow table

Measuring span: 10 : 1
 Declaration of flow: Values = 100%
 Water: 20°C [68°F]
 Air: 20°C [68°F], 1,2 bar abs. [17.4 psia]

Cones	Water flow rate		Air flow rate		Pressure drop	
	[l/h]	[GPH]	[NL/h]	[SCFH]	[mbar]	[psig]
K 005	-	-	16 ①	0.6 ①	14	0.21
K 005	-	-	50	1.9	31	0.46
K 010	1.5 ①	0.40 ①	70 ①	2.6 ①	66	0.97
K 010	3	0.8	100	3.7	66	0.97
K 015	5	1.3	150	5.6	19	0.28
K 040	10	2.5	400	15	27	0.40
K 080	25	6.5	800	30	55	0.81
K 125	40	11	1250	45	42	0.62
K 200	60	16	2000	75	85	1.25
K 300	80	20	2500	90	117	1.72
K 340	100	25	3400	130	166	2.44

① with titanium float

The operating pressure should be at least twice the pressure loss for liquids, and at least 5 times the pressure loss for gases! The specified pressure drops are valid for water and air at maximum flow rate. Other flow ranges on request. Conversion of other media or operating data (pressure, temperature, density, viscosity) is performed using the calculation method in accordance with VDI/VDE Directive 3513

Reference condition for gas measurements:

The flow measurement of gases are referred to

NL/h or Nm³/h: Volume flow in Normal state 0°C, 1.013 bar abs. (DIN 1343)

SCFM or SCFH: Volume flow in Standard state 15°C, 1.013 bar abs. (ISO 13443)

Valves

Measuring span: 10 : 1
 Declaration of flow: Values = 100%
 Water: 20°C [68°F]
 Air: 20°C [68°F], 1,2 bar abs. [17.4 psia]

only DK32 and DK37		Max. low rate Qv				Characteristic	
Valve spindle		Water		Air		Kv	Cv
Cones	Ø [mm] / Ø ["]	[l/h]	[GPH]	[NI/h]	[SCFH]	[m ³ /h]	[GPM]
K 005 - K 010	1 / 0,039	5	1,32	100	3,72	0,018	0,021
K 015 - K 040 - K 080	2.5 / 0,98	50	13,2	1000	37,2	0,15	0,175
K 125 ... K 340	4.5 / 0,177	160	42,3	4300	160	0,48	0,552

Valve characteristics

Spindle 1,0mm - 0,039"

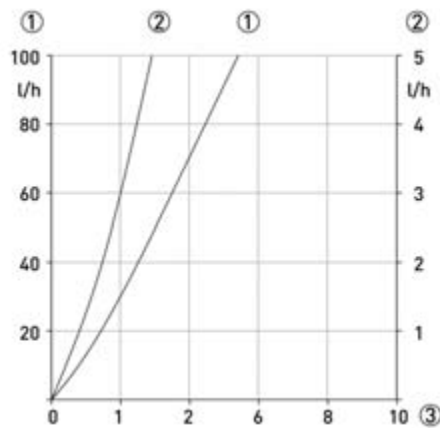

Spindle 2,5mm - 0,098"

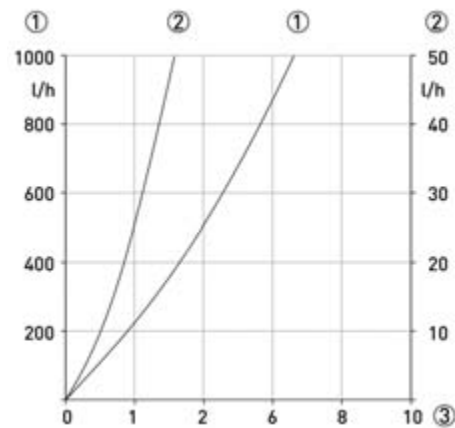

Spindle 4,5mm - 0,177"

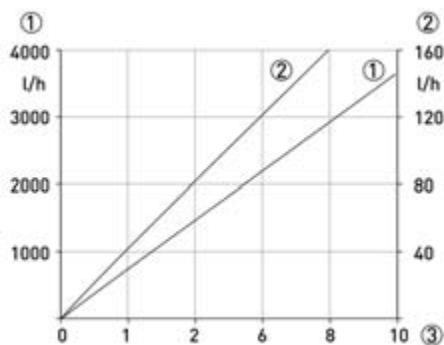

- ① Flow, air
- ② Flow, water
- ③ Spindle rotation n

2.4 Differential pressure regulators

Differential pressure regulators are used (DK32 and DK37 only) to help maintain constant flow rates in the case of fluctuating inlet or outlet pressures. Minimum pressure levels are required to permit operation of the regulators (see Regulator characteristics).

Differential pressure regulators are not pressure reducing valves!

① Inlet pressure regulators, types RE, NRE

The regulators maintain a constant flow rate at variable inlet pressure and constant outlet pressure.

Example: Inlet pressure regulator RE-1000:	Current flow rate:	1000l/h air
	Constant outlet pressure p2:	1.013 bar abs.

With a variable inlet pressure greater than 0.5 bar the flow rate in the device is constant.

② Outlet pressure regulators types RA, NRA

The regulators maintain a constant flow rate at constant inlet pressure and variable outlet pressure.

In order to function, there must be pressure difference between the inlet pressure and the outlet pressure. The inlet pressure p1 must always be greater than the outlet pressure p2.

Example: Outlet pressure regulator NRA-800	Current flow rate:	800l/h air
	Constant inlet pressure:	6 bar

With a variable outlet pressure of 0...5.5 bar the flowrate in the device remains constant.

Regulator characteristics

① Inlet pressure regulators, types RE and NRE

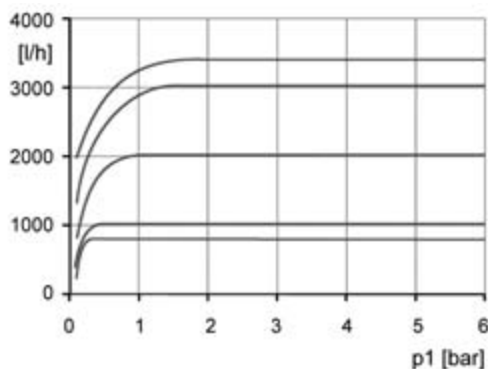

② Outlet pressure regulators, types RA and NRA

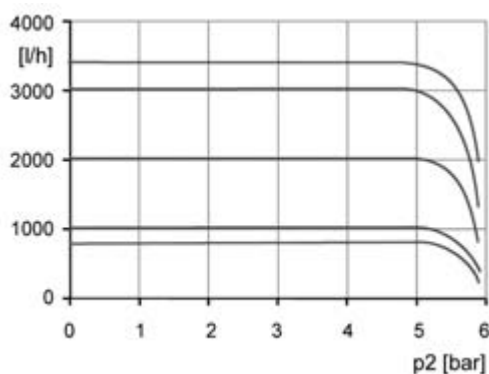

Control range

Measuring span:	10 : 1
Declaration of flow:	Values = 100%
	Water: 20°C [68°F]
	Air: 20°C [68°F], 1,2 bar abs. [17.4 psia]

Inlet pressure regulator ①

	Max. flowrate				Min. inlet pressure	
	Water		Air		Min. inlet pressure	
	[l/h]	[GPH]	[NI/h]	[SCFH]	p1 [bar]	p1 [psig]
RE-1000	...40	...11	...1000	...37	0.5	7,25
RE-4000	...80	...20	...2000	...75	1	14,5
	...100	...25	...3000	...110	1.5	21,8
	...160	...42	...4000	...150	2	29
NRE-100	...2.5	...0.6	...100	...3,7	0.1	1,45
NRE-800	-	-	...250	...9,0	0.1	1,45
	-	-	...800	...30	0.2	2,9
	...25	...6.60	-	-	0.4	5,8

Outlet pressure regulator ②

	Max. flowrate				Min. pressure diff. *	
	Water		Air		Min. pressure diff. *	
	[l/h]	[GPH]	[NI/h]	[SCFH]	Δp [bar]	Δp [psig]
RA-1000	...40	...11	...1000	...37	0,4	5,8
RA-4000	...100	...25	...2000	...75	1,2	17,4
	-	-	...3000	...110	1,2	17,4
	...160	...42	...4000	...150	1,5	21,8
NRA-800	...1	...0.25	...250	...9,0	0,05	0,73
	-	-	...500	...19	0,1	1,45
	-	-	...800	...30	0,2	2,9
	...25	...6.6	-	-	0,4	5,8

--

Reference condition for gas measurements:

The flow measurement of gases are referred to

NI/h or Nm³/h: Volume flow in Normal state 0°C, 1.013 bar abs. (DIN 1343)

SCFM or SCFH: Volume flow in Standard state 15°C, 1.013 bar abs. (ISO 13443)

Technical data, differential pressure regulator

Standard connections	1/4" NPT
Option	Serto, Ermeto 6 or 8, tube nozzle 6mm or 8mm, Dilo, Gyrolok, Swagelok, G 1/4
Max. operating gauge pressure (at 20°C)	64 bar / 928psig
Medium temperature	150°C / 302°F
Material	CrNi-Steel 1.4404
Gasket	PTFE
Membrane	PTFE filled with carbon / graphite
O-ring	FPM

other connections and materials, higher temperatures and pressures on request

Dimensions with differential pressure regulators

	a (approx.)		b (approx.)		c		d	
	[mm]	["]	[mm]	["]	[mm]	["]	[mm]	["]
DK32	230	9.1	163	6.4	70	2.8	23	0.91
DK37	230	9.1	200	7.9	70	2.8	23	0.91
DK37/M8M ①	230	9.1	230	9.1	70	2.8	23	0.91

① with outlet pressure regulator

DK32 with inlet pressure regulator

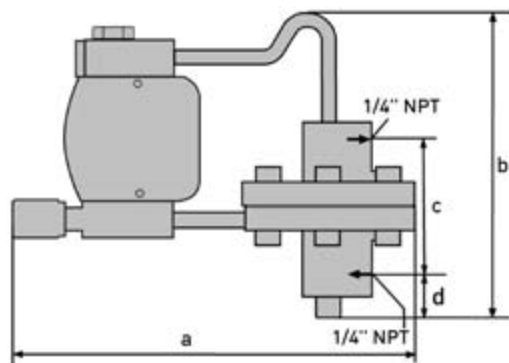

DK37/M8E and M8M with inlet pressure regulator

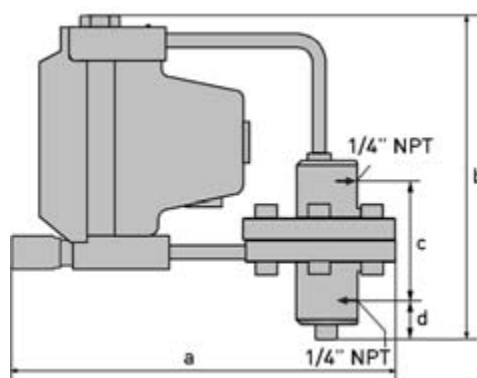

DK32 with outlet pressure regulator

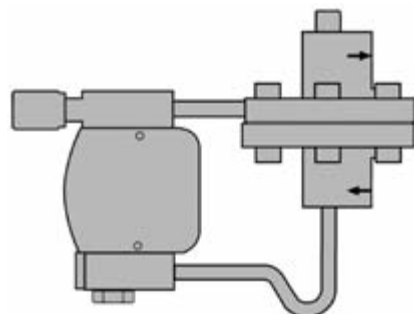

DK37/M8E with outlet pressure regulator

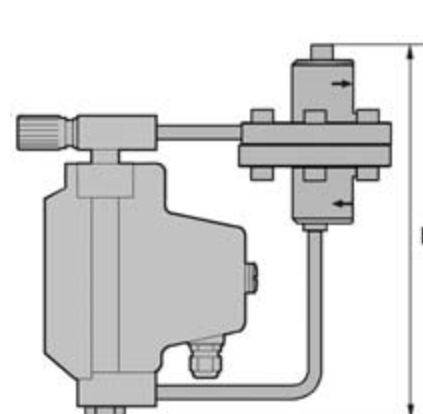

3.1 Intended use

Responsibility for the use of the measuring devices with regard to suitability, intended use and corrosion resistance of the used materials against the measured fluid lies solely with the operator.

The manufacturer is not liable for any damage resulting from improper use or use for other than the intended purpose.

The variable area flowmeters manufactured by KROHNE Messtechnik GmbH are suitable for measuring gases, vapors and liquids.

These flowmeters are particularly suitable for measuring:

- Liquids
- Hydrocarbons
- Water
- Chemicals with low corrosiveness
- Saturated steam
- Superheated steam
- Industrial gases

In case of instruments which are used in explosive endangered areas please consider the supplementary installation and operating instructions mentioned in the Ex-manual.

The operator shall bear sole responsibility for the use of the flowmeters with regard to suitability, intended use and corrosion resistance of the materials used to the process product. The manufacturer shall not be liable for any damage resulting from improper use or use for other than the intended purpose.

Do not use any abrasive or highly viscous process products.

3.2 Installation requirements

When installing the flowmeter in the piping please observe the following points:

- *The variable area flowmeter must be installed vertically (measuring principle). The flow direction must be from bottom to top. For installation recommendations please refer also to VDI/VDE Directive 3513 Sheet 3.*
- *Before connecting, blow or flush out the pipes leading to the flowmeter.*
- *Pipes for gas flow need to be dried before the flowmeter is installed.*
- *Use connectors suitable for the particular version of the flowmeter.*
- *Align the pipes axially with the connections on the flowmeter so that they are free of stresses.*
- *If necessary, the piping has to be supported to prevent vibrations being transmitted to the flowmeter.*
- *Do not lay signal cables directly next to cables for the power supply.*
- *If several instruments are installed side by side, a minimum distance between these devices is required (see Technical Data).*

4.1 Electrical connection of limit switches

The electrical connections for limit switches is effected:

- DK../../S - in the plug connector
- DK../../L - using a preassembled cable.

The following procedures must be performed (DK../../S):

- Slacken screw ⑥ of the connector plug
- Pull out the plug
- Remove screw ⑥ completely from the plug
- Insert a screwdriver in the marked opening ⑤ (Lift) and remove the terminal block.
- Thread the connecting cable through the cable gland.
- Insert the cable (max. 1.5mm²) and screw down.

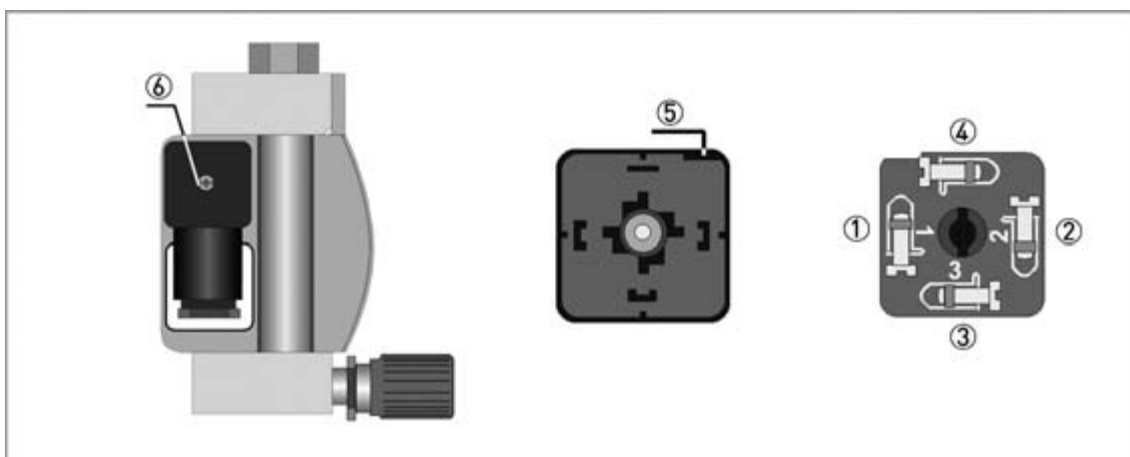

Figure 4-1: Electrical connection of limit switches

⑤ - Lift slot

⑥ - Fastening screw of terminal box

	Contact connection	Cable colors of assembled cable
①	Min minus	white
②	Min plus	yellow
③	Max minus	green
④	Max plus	brown

Connection three-wire reed contact

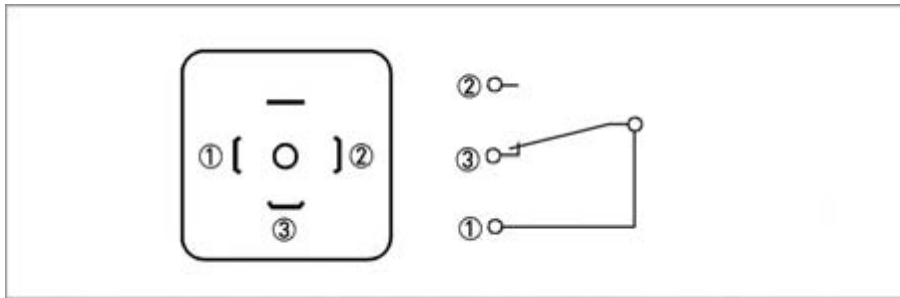

Figure 4-2: Electrical connection of reed contact limit switch

Strand colours for flowmeters with preassembled cables:

- ① Silicone-insulated wire - yellow/green / FEP-insulated wire - red
- ② Silicone-insulated wire - brown / FEP-insulated wire - brown
- ③ Silicone-insulated wire - blue / FEP-insulated wire - blue

4.2 DK37/M8M limit switches

The limit switches can be set over the entire measuring range using the maximum pointer. The set limit values are displayed on the scale. The pointers are set to the desired limit values using a slip coupling along the scale.

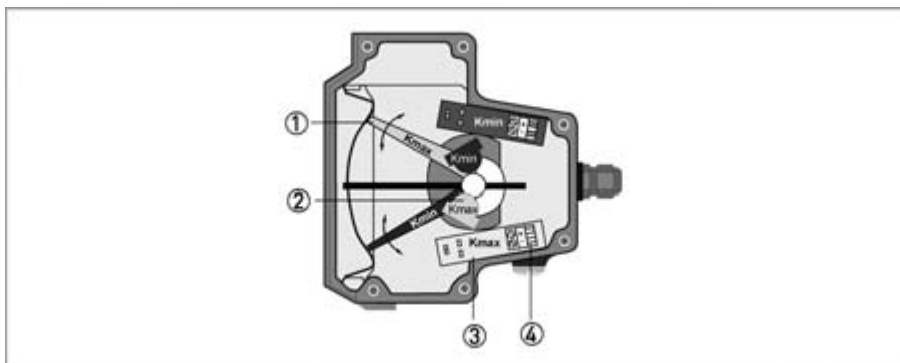

Figure 4-3: Limit switch setting

- ① Maximum pointer, switching point indicator
- ② Limit switch
- ③ Connection board
- ④ Connection terminal

4.3 DK37/M8E electrical signal output

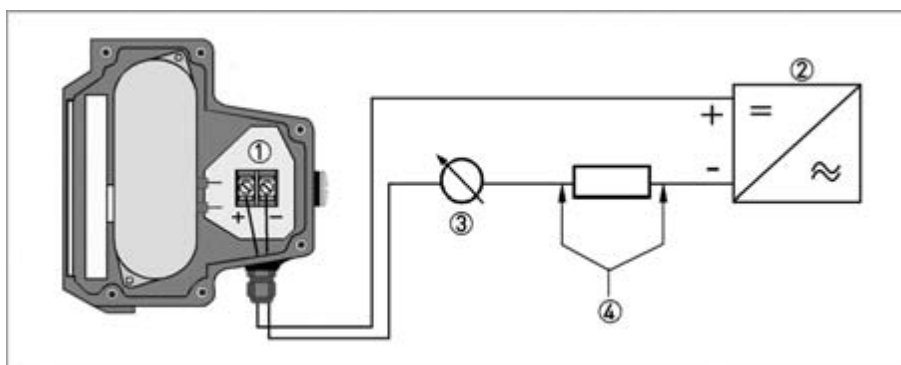

Figure 4-4: Electrical connection M8E

- ① Terminal connection
- ② Auxiliary power 14.8...30VDC
- ③ Measurement signal 4...20mA
- ④ External load, HART® communication

The circuitry for connection to other devices such as digital evaluator units or process control equipment must be designed with especial care. In some circumstances internal connections in these devices (e.g. GND with PE, ground loops) may lead to impermissible voltage potentials, which can compromise the function of the device itself or a connected device. In such cases a protected extra-low voltage (PELV) is recommended.

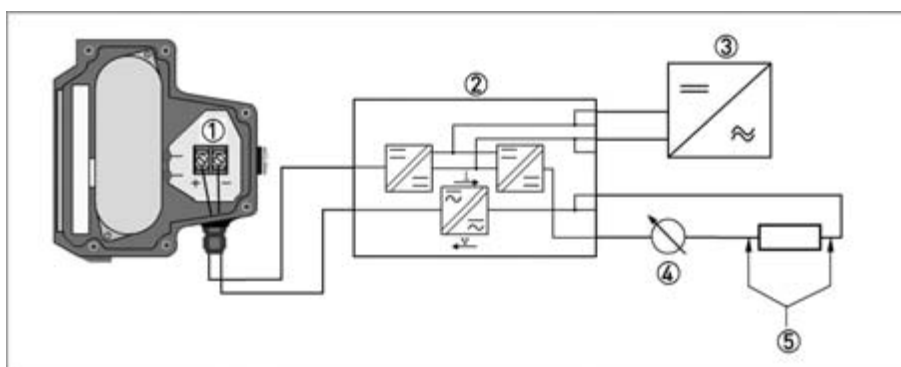

Figure 4-5: Electrical connection with galvanic isolation

- ① Terminal connection
- ② Converter supply isolator with galvanic isolation
- ③ Auxiliary power (see supply isolator information)
- ④ Measurement signal 4...20mA
- ⑤ External load, HART® communication

4.3.1 Power supply

The supply voltage has to be between 14.8VDC and 30VDC. This is based on the total resistance of the measuring loop. To determine this, add up the resistances of each component in the measuring loop (not including the meter).

The required supply voltage can be calculated using the formula below:

$$U_{\text{ext.}} = R_L \cdot 22\text{mA} + 14.8\text{V}$$

where

$U_{\text{ext.}}$ = the minimum supply voltage and

R_L = the total measuring loop resistance.

The power supply has to be able to supply a minimum of 22mA.

4.3.2 Load for HART[®] communication

For HART[®] communication a load of at least 230 ohm is required.

The maximum load impedance is calculated as follows:

$$R_L = \frac{U_{\text{ext.}} - 14.8\text{V}}{22\text{mA}}$$

Use a twisted two-core cable to prevent electrical interference from impeding the DC output signal.

In some cases a shielded cable may be necessary. The cable shield may only be earthed (grounded) at one place (on the power supply unit).

4.3.3 Parametrization

The M8E electronic display can be parametrized via HART[®] communications. DD (Device Descriptions) for AMS 6.x and PDM 5.2 and a DTM (Device Type Manager) are available for parametrization (download center).

The current flowrate can be transmitted using the integral HART[®] communications. A flow counter can be parametrized. Two limit values can be monitored. The limit values are assigned either to flow values or to the counter overflow. The limit values are not depicted on the display.

Please provide us with the missing information so that we can be of help to you as quickly as possible.

Then please fax this page to the appropriate sales associate. We will then contact you as soon as possible.

Device data

Connection type:	<input type="checkbox"/> 1/4" NPT	<input type="checkbox"/> (other)		
Connection:	<input type="checkbox"/> horizontal	<input type="checkbox"/> vertical		
Pressure rating:				
Device:	<input type="checkbox"/> DK32	<input type="checkbox"/> DK34	<input type="checkbox"/> DK37M8M	<input type="checkbox"/> DK38M8E
Options:	<input type="checkbox"/> K1 ① <input type="checkbox"/> K2 ②	<input type="checkbox"/> K1 ① <input type="checkbox"/> K2 ②	<input type="checkbox"/> K1 ① <input type="checkbox"/> K2 ②	
Differential pressure regulator:	<input type="checkbox"/> Inlet pressure regulator		<input type="checkbox"/> Outlet pressure regulator	
Approval:	<input type="checkbox"/> Without	<input type="checkbox"/> ATEX	<input type="checkbox"/> FM	<input type="checkbox"/> NEPSI

① 1 Limit switch

② 2 Limit switches

Rating data

Product:			
Operating pressure:		<input type="checkbox"/> Absolute pressure	<input type="checkbox"/> Overpressure
Rated pressure:			
Operating temperature:			
Rated temperature:			
Density:		<input type="checkbox"/> Standard density	<input type="checkbox"/> Operating density
Viscosity:			
Measuring range:			
Comments:			

Contact data

Company:	
Contact person:	
Telephone number:	
Fax number:	
E-mail:	







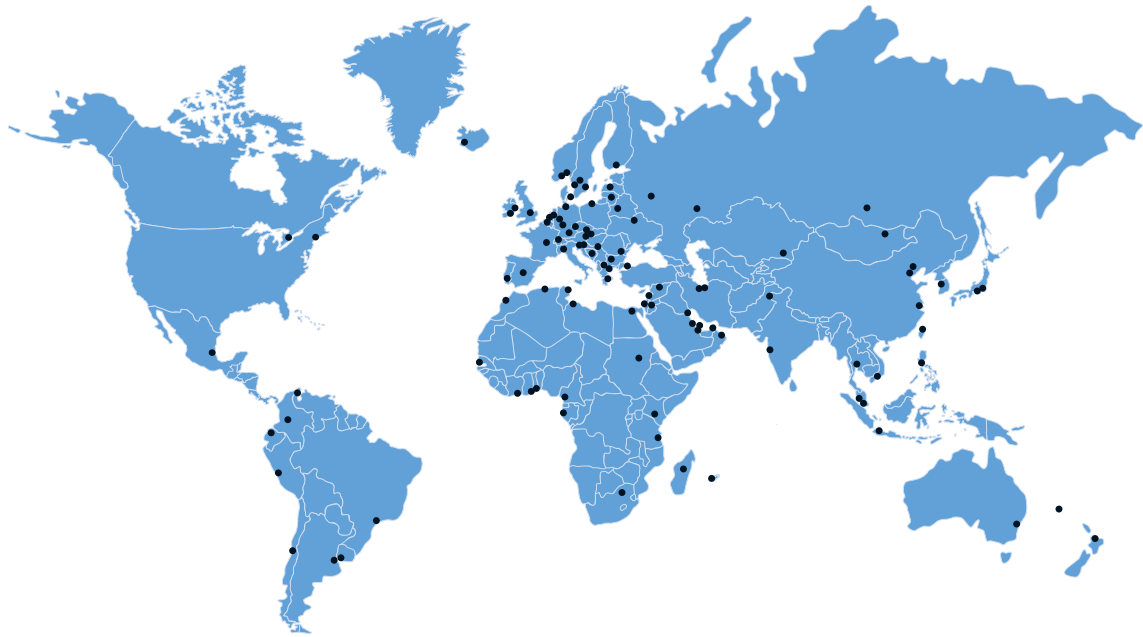

KROHNE product overview

- Electromagnetic flowmeters
- Variable area flowmeters
- Ultrasonic flowmeters
- Mass flowmeters
- Vortex flowmeters
- Flow controllers
- Level meters
- Temperature meters
- Pressure meters
- Analysis products
- Measuring systems for the oil and gas industry
- Measuring systems for sea-going tankers

Head Office KROHNE Messtechnik GmbH
Ludwig-Krohne-Str. 5
D-47058 Duisburg (Germany)
Tel.: +49 (0)203 301 0
Fax: +49 (0)203 301 10389
info@krohne.de

The current list of all KROHNE contacts and addresses can be found at:
www.krohne.com

KROHNE