

Rosemount 644 Temperature Transmitter

- *Versatile temperature transmitter delivers field reliability and advanced accuracy to meet demanding process needs*
- *Optimize plant efficiency and increase measurement reliability with industry-proven capabilities and specifications*
- *A standard diagnostic offering provides visibility into process conditions*
- *Explore the benefits of a Complete Point Solution from Rosemount Temperature*



Contents

Rosemount 644 Temperature Transmitter.....	page 2
Ordering Information	page 4
Specifications	page 8
Product Certifications	page 13
Dimensional Drawings.....	page 18

Rosemount 644 Temperature Transmitter

Versatile temperature transmitter delivers field reliability and advanced accuracy to meet demanding process needs

- DIN A style Head Mount transmitter or Rail Mount transmitter
- Variety of DIN A enclosure options
- Single sensor capability with universal sensor inputs (RTD, T/C, mV, ohms)
- HART / 4-20 mA, FOUNDATION fieldbus or Profibus PA protocols
- Transmitter-Sensor Matching with Callendar-Van Dusen
- LCD display



Optimize plant efficiency and increase measurement reliability with industry-proven capabilities and specifications

- Two-year stability rating reduces maintenance costs
- Transmitter-Sensor Matching eliminates the interchangeability error of sensors, improving measurement point accuracy by 75%
- PlantWeb alerts and user-centric Device Dashboards communicate important diagnostics and ensure process health
- Compensation for ambient temperatures enhances transmitter performance
- Aluminum or stainless steel connection heads for simplified electrical connections and wiring

A standard diagnostic offering provides visibility into process conditions



- Open/short sensor diagnostics assist with detecting issues in the sensor loop
- Intermittent Sensor Detect and Open Sensor Holdoff provide reliability in high vibration and noisy environments
- The terminal temperature feature verifies the installation temperature to ensure optimal transmitter operation

Product Data Sheet

00813-0100-4728, Rev RC

February 2012

Rosemount 644

Explore the benefits of a Complete Point Solution from Rosemount Temperature Measurement

- An “Assemble To Sensor” option enables Emerson to provide a complete point temperature solution, delivering an installation-ready transmitter and sensor assembly
- Emerson offers a selection of RTDs, thermocouples, and thermowells that bring superior durability and Rosemount reliability to temperature sensing, complementing the Rosemount Transmitter portfolio



Experience global consistency and local support from numerous worldwide Rosemount Temperature manufacturing sites



- World-class manufacturing provides globally consistent product from every factory and the capacity to fulfill the needs of any project, large or small.
- Experienced Instrumentation Consultants help select the right product for any temperature application and advise on best installation practices.
- An extensive global network of Emerson service and support personnel can be on-site when and where they are needed.

-
- Critical measurement points that require advanced diagnostics, safety-certification or dual sensor redundancy are ideal for the Rosemount 3144P temperature transmitter.
 - For installations that have a high number of temperature measurement in close proximity, consider the Rosemount 848T High Density temperature transmitter.
-

Rosemount 644 Temperature Transmitter

The Rosemount 644 is a versatile temperature transmitter that delivers field reliability and advanced accuracy to meet demanding process needs.

Transmitter features include:

- HART / 4-20 mA, FOUNDATION fieldbus or Profibus PA protocols
- DIN A or Rail Mount transmitter types
- LCD Display (Option Code M5 or M6)
- Transmitter-Sensor Matching (Option Code C2)
- 3-Point Calibration Certificate (Option Code Q4)
- Assemble to Sensor options (Option Code XA)



Table 1. Rosemount 644 Smart Temperature Transmitter Ordering Information

★ The Standard offering represents the most common models and options. These options should be selected for best delivery.
The Expanded offering is manufactured after receipt of order and is subject to additional delivery lead time.

		● = Available – = Not Available				
Model	Product Description					
644	Temperature Transmitter					
Transmitter Type						
Standard						
H	DIN A Head Mount (suitable for mounting in the field with enclosure options below)					★
R	Rail Mount					★
Output		Head	Rail			
Standard						
A	4–20 mA with digital signal based on HART protocol	●	●	★		
F	FOUNDATION fieldbus digital signal (includes 2 AI function blocks and Backup Link Active Scheduler)	●	–	★		
W	Profibus PA digital signal	●	–	★		
Product Certifications						
Hazardous Locations Certificates (consult factory for availability)						
		A	F	W	A	
Standard						
NA	No approval	●	●	●	●	★
E5 ⁽¹⁾	FM Explosion-Proof	●	●	●	–	★
I5 ⁽²⁾	FM Intrinsically Safe	●	●	●	●	★
K5 ⁽²⁾⁽¹⁾	FM Intrinsically Safe, Explosion-Proof Combination	●	●	●	–	★
KC	FM/CSA Intrinsically Safe and Non-incendive Approval	●	●	●	–	★
I6 ⁽²⁾	CSA Intrinsically Safe	●	●	●	–	★
K6 ⁽¹⁾⁽³⁾	CSA Intrinsically Safe, Explosion-Proof Combination	●	●	●	–	★
E1 ⁽¹⁾	ATEX Flameproof	●	●	●	–	★
I1 ⁽²⁾	ATEX Intrinsically Safe	●	●	●	●	★
N1 ⁽¹⁾	ATEX Type n	●	●	●	–	★
NC	ATEX Type n Component	●	●	●	●	★
ND ⁽¹⁾	ATEX Dust Ignition-Proof	●	●	●	–	★
E7 ⁽¹⁾	IECEx Flameproof and Dust	●	●	●	–	★
I7 ⁽²⁾	IECEx Intrinsically Safe	●	●	●	●	★

Table 1. Rosemount 644 Smart Temperature Transmitter Ordering Information

★ The Standard offering represents the most common models and options. These options should be selected for best delivery.
 The Expanded offering is manufactured after receipt of order and is subject to additional delivery lead time.

		● = Available - = Not Available				
N7 ⁽¹⁾	IECEX Type n	●	●	●	-	★
NG	IECEX Type n Component	●	●	●	●	★
E2 ⁽¹⁾	INMETRO Flameproof	●	●	●	-	★
E4 ⁽¹⁾⁽³⁾	TIIS Explosion-Proof	●	●	●	●	★
E3 ⁽¹⁾	China Flameproof	●	●	●	-	★
I3	China Intrinsic Safety	●	●	●	-	★

Options

		A	F	W	A	
PlantWeb Control Functionality						
Standard						Standard
A01	FOUNDATION fieldbus Advanced Control Function Block Suite	-	●	-	-	★
Assemble To Options						
Standard						Standard
XA	Sensor Specified Separately and Assembled To Transmitter	●	●	●	-	★
		Head			Rail	
		A	F	W	A	
Enclosure Options						
Standard						Standard
J5 ⁽⁴⁾⁽⁵⁾	Universal Head (junction box), aluminum alloy with 50.8 mm (2-in.) SST pipe bracket (M20 entries)	●	●	●	-	★
J6 ⁽⁴⁾	Universal Head (junction box), aluminum alloy with 50.8 mm (2-in.) SST pipe bracket (1/2-14 NPT entries)	●	●	●	-	★
J7 ⁽⁴⁾⁽⁵⁾	Universal Head (junction box), cast SST with 50.8 mm (2-in.) SST pipe bracket (M20 entries)	●	●	●	-	★
J8 ⁽⁴⁾	Universal Head (junction box), cast SST with 50.8 mm (2-in.) SST pipe bracket (1/2-14 NPT entries)	●	●	●	-	★
Expanded						
S1	Connection Head, Polished Stainless Steel (1/2-14 NPT entries)	●	●	●	-	
S2	Connection Head, Polished Stainless Steel (1/2-14 NPSM entries)	●	●	●	-	
S3	Connection Head, Polished Stainless Steel (M20 x 1.5 conduit and entries)	●	●	●	-	
S4	Connection Head, Polished Stainless Steel (M20 x 1.5 conduit entries, M24 x 1.5 head entry)	●	●	●	-	
Display						
Standard						Standard
M5	LCD Display	●	●	●	-	★
Expanded						
M6	LCD Display with Polycarbonate Meter Face	●	●	●	-	
Software Configuration						
Standard						Standard
C1	Custom Configuration of Date, Descriptor and Message (Requires CDS with order)	●	●	●	●	★
Alarm Level Configuration						
Standard						Standard
A1	NAMUR alarm and saturation levels, high alarm	●	-	-	●	★
CN	NAMUR alarm and saturation levels, low alarm	●	-	-	●	★
C8	Low Alarm (Standard Rosemount Alarm and Saturation Values)	●	-	-	●	★
Line Filter						
Standard						Standard
F6	60 Hz Line Voltage Filter	●	●	●	●	★

Rosemount 644

Table 1. Rosemount 644 Smart Temperature Transmitter Ordering Information

★ The Standard offering represents the most common models and options. These options should be selected for best delivery.
The Expanded offering is manufactured after receipt of order and is subject to additional delivery lead time.

		● = Available - = Not Available				
Sensor Trim						
Standard						Standard
C2	Transmitter-Sensor Matching - Trim to Specific Rosemount RTD Calibration Schedule (CVD constants)	●	●	●	●	★
5-Point Calibration Option						
Standard						Standard
C4	5-point calibration. Use option code Q4 to generate a calibration certificate	●	●	●	●	★
Calibration Certificate						
Standard						Standard
Q4	Calibration certificate. 3-Point calibration with certificate	●	●	●	●	★
External Ground						
Standard						Standard
G1	External ground lug assembly (see "External Ground Screw Assembly" on page 7)	●	●	●	-	★
Cable Gland Option						
Standard						Standard
G2	Cable gland ⁽⁶⁾ (7.5 mm - 11.99 mm)	●	●	●	-	★
G7	Cable gland, M20x1.5, Ex e, Blue Polyamide (5 mm - 9 mm)	●	●	●	-	★
Cover Chain Option						
Standard						Standard
G3	Cover chain	●	●	●	-	★
Conduit Electrical Connector						
Standard						Standard
GE ⁽⁷⁾	M12, 4-pin, Male Connector (eurofast [®])	●	●	●	-	★
GM ⁽⁷⁾	A size Mini, 4-pin, Male Connector (minifast [®])	●	●	●	-	★
External Label						
Standard						Standard
EL	External label for ATEX Intrinsic Safety	●	●	●	-	★
Typical Rail Mount Model Number: 644 R A I5						
Typical Head Mount Model Number: 644 H F I5 M5 J5 C1						

(1) Requires enclosure option J5, J6, J7, or J8.

(2) When IS approval is ordered on a FOUNDATION fieldbus, both standard IS and FISCO IS approvals apply. The device label is marked appropriately.

(3) Consult factory for availability.

(4) Suitable for remote mount configuration.

(5) When ordered with XA, 1/2-in. NPT enclosure will come equipped with an M20 adapter with the sensor installed as process ready.

(6) Only available with Enclosure option code J5.

(7) Available with Intrinsically Safe approvals only. For FM Intrinsically Safe or non-incendive approval (option code I5), install in accordance with Rosemount drawing 03151-1009 to maintain NEMA 4X rating.

NOTE

For additional options (e.g. "K" codes), please contact your local Emerson Process Management representative.

Tagging

Hardware

- 13 characters total
- Tags are adhesive labels
- Permanently attached to transmitter
- Character height is ¹/₁₆-in (1.6 mm)

Software

- Order with C1 option
- The transmitter can store up to 13 characters for FOUNDATION fieldbus and Profibus PA or 8 for HART protocol. If no characters are specified, the first 8 characters of the hardware tag are the default.

Considerations

Special Mounting Considerations

See "Mounting Kits for both 644H and 644R" on page 19 for the special hardware that is available to:

- Mount a 644H to a DIN rail. (see Table 2 on page 7)
- Retrofit a new 644H to replace an existing 644H transmitter in an existing threaded sensor connection head.(see Table 2 on page 7)

External Ground Screw Assembly

The external ground screw assembly can be ordered by specifying code G1 when an enclosure is specified. However, some approvals include the ground screw assembly in the transmitter shipment, hence it is not necessary to order code G1. The table below identifies which approval options include the external ground screw assembly and which do not.

Approval Type	External Ground Screw Assembly Included?
E5, I1, I2, I5, I6, I7, K5, K6, NA, I4	No—Order option code G1
E1, E2, E3, E4, E7, K7, N1, N7, ND	Yes

Table 2. Transmitter Accessories

Part Description	Part Number
Aluminum alloy Universal Head, standard cover—M20 entries	00644-4420-0002
Aluminum alloy Universal Head, meter cover—M20 entries	00644-4420-0102
Aluminum alloy Universal Head, standard cover— ¹ / ₂ -14 NPT entries	00644-4420-0001
Aluminum alloy Universal Head, meter cover— ¹ / ₂ -14 NPT entries	00644-4420-0101
LCD Display (includes meter and meter spacer assembly)	00644-4430-0002
LCD Display kit (includes meter and meter spacer assembly, and meter cover)	00644-4430-0001
Ground screw assembly kit	00644-4431-0001
Kit, Hardware for mounting a 644H to a DIN rail (includes clips for symmetrical and asymmetrical rails)	00644-5301-0010
Kit, Hardware for retrofitting a 644H in an existing threaded sensor connection head (former option code L1)	00644-5321-0010
Kit, 316 U-Bolt for Universal Housing	00644-4423-0001
Universal clip for rail or wall mount	03044-4103-0001
24 Inches of symmetric (top hat) rail	03044-4200-0001
24 Inches of asymmetric (G) Rail	03044-4201-0001
Ground clamp for symmetric or asymmetric rail	03044-4202-0001
End clamp for symmetric or asymmetric rail	03044-4203-0001
Snap rings kit (used for assembly to a DIN sensor – quantity 12)	00644-4432-0001
SST Universal Head, standard cover—M20 entries	00644-4433-0002
SST Universal Head, meter cover—M20 entries	00644-4433-0102
SST Universal Head, standard cover— ¹ / ₂ -14 NPT entries	00644-4433-0001
SST Universal Head, meter cover— ¹ / ₂ -14 NPT entries	00644-4433-0101
Polished SST Connection Head, standard cover— ¹ / ₂ -14 NPT entries	00079-0312-0011
Polished SST Connection Head, meter cover— ¹ / ₂ -14 NPT entries	00079-0312-0111
Polished SST Connection Head, standard cover— ¹ / ₂ -14 NPSM entries	00079-0312-0022
Polished SST Connection Head, meter cover— ¹ / ₂ -14 NPSM entries	00079-0312-0122
Polished SST Connection Head, standard cover—M20 x 1.5 entries	00079-0312-0033
Polished SST Connection Head, meter cover—M20 x 1.5 entries	00079-0312-0133
Polished SST Connection Head, standard cover—M20 x 1.5 / M24 x 1.5 entries	00079-0312-0034
Polished SST Connection Head, meter cover—M20 x 1.5 / M24 x 1.5 entries	00079-0312-0134

Specifications

HART, FOUNDATION FIELDBUS, AND PROFIBUS PA

Functional Specifications

Inputs

User-selectable; sensor terminals rated to 42.4 Vdc. See "Accuracy" on page 11 for sensor options.

Output

Single 2-wire device with either 4–20 mA/HART, linear with temperature or input; or completely digital outputs with FOUNDATION fieldbus communication (ITK 5.01 compliant), or Profibus PA (compliant with profile 3.02).

Isolation

Input/output isolation tested to 600 Vrms.

Local Display

The optional five-digit integral LCD Display includes a floating or fixed decimal point. It can also display engineering units (°F, °C, °R, K, Ω, and mV), mA, and percent of span. The display can be configured to alternate between selected display options. Display settings are preconfigured at the factory according to the standard transmitter configuration. They can be reconfigured in the field using either HART, FOUNDATION fieldbus or Profibus PA communications.

Humidity Limits

0–99% relative humidity

Update Time

≤ 0.5 sec.

Accuracy (default configuration) PT 100

HART (0-100 °C): ±0.18 °C

FOUNDATION fieldbus: ±0.15 °C

Profibus PA: ±0.15 °C

Physical Specifications

Electrical Connections

Model	Power and Sensor Terminals
644H	Compression screws permanently fixed to terminal block
644R	Compression screw permanently fixed to front panel

Field Communicator Connections

Communication Terminals	
644H	Clips permanently fixed to terminal block
644R	Clips permanently fixed to front panel

Materials of Construction

Electronics Housing and Terminal Block	
644H	Noryl [®] glass reinforced
644R	Lexan [®] polycarbonate
Enclosure (Option code J5 or J6)	
Housing	Low-copper aluminum
Paint	Polyurethane
Cover O-ring	Buna-N

Materials of Constructions (Stainless Steel Housing for Biotechnology, Pharmaceutical Industries, and Sanitary Applications)

Housing and Standard Meter Cover

- 316 SST

Cover O-Ring

- Buna-N

Mounting

The 644R attaches directly to a wall or a DIN rail. The 644H installs in a connection head or universal head mounted directly on a sensor assembly, apart from a sensor assembly using a universal head, or to a DIN rail using an optional mounting clip.

Weight

Code	Options	Weight
644H	HART, Head Mount Transmitter	96 g (3.39 oz)
644H	FOUNDATION fieldbus, Head Mount Transmitter	92 g (3.25 oz)
644H	Profibus PA Head Mount Transmitter	92 g (3.25 oz)
644R	HART, Rail Mount Transmitter	174 g (6.14 oz)
M5	LCD Display	38 g (1.34 oz)
J5, J6	Universal Head, Standard Cover	577 g (20.35 oz)
J5, J6	Universal Head, Meter Cover	667 g (23.53 oz)
J7, J8	SST Universal Head, Std. Cover	1620 g (57.14 oz)
J7, J8	SST Universal Head, Meter Cover	1730 g (61.02 oz)

Weight (Stainless Steel Housing for Biotechnology, Pharmaceutical Industries, and Sanitary Applications)

Option Code	Standard Cover	Meter Cover
S1	840 g (27 oz)	995 g (32 oz)
S2	840 g (27 oz)	995 g (32 oz)
S3	840 g (27 oz)	995 g (32 oz)
S4	840 g (27 oz)	995 g (32 oz)

Enclosure Ratings (644H)

All option codes (S1, S2, S3, S4, J5, J6, J7, J8, R1, R2, R3 and R4) are NEMA 4X, IP66, and IP68. Option code J6 is CSA Enclosure Type 4X.

Sanitary Housing Surface

Surface finish is polished to 32 RMA. Laser etched product marking on housing and standard covers.

Performance Specifications

**EMC (ElectroMagnetic Compatibility)
NAMUR NE 21 Standard**

The 644H HART meets the requirements for NAMUR NE 21 Rating.

Susceptibility	Parameter	Influence
		HART
ESD	<ul style="list-style-type: none"> 6 kV contact discharge 8 kV air discharge 	None
Radiated	80 – 1000 MHz at 10 V/m AM	< 0.5%
Burst	1 kV for I.O.	None
Surge	<ul style="list-style-type: none"> 0.5 kV line–line 1 kV line–ground (I.O. tool) 	None
Conducted	150 kHz to 80 MHz at 10 V	< 0.5%

CE Electromagnetic Compatibility Compliance Testing

The 644 is compliant with Directive 2004/108/EC. Meets the criteria under IEC 61326:2006

Power Supply Effect

Less than ±0.005% of span per volt

Stability

RTDs and thermocouples have a stability of ±0.15% of output reading or 0.15 °C (whichever is greater) for 24 months

Self Calibration

The analog-to-digital measurement circuitry automatically self-calibrates for each temperature update by comparing the dynamic measurement to extremely stable and accurate internal reference elements.

Vibration Effect

The 644 is tested to the following specifications with no effect on performance per IEC 60770-1, 1999:

Frequency	Vibration
10 to 60 Hz	0.21 mm displacement
60 to 2000 Hz	3 g peak acceleration

Sensor Connections

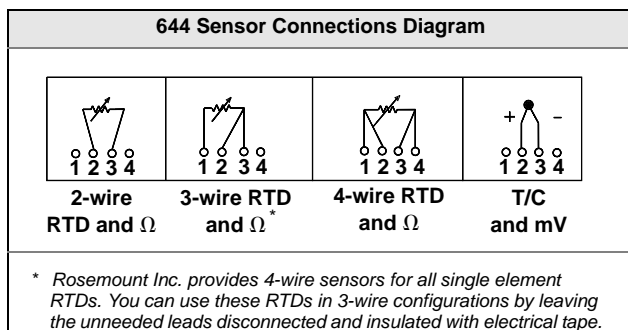

FOUNDATION FIELDBUS SPECIFICATIONS

Function Blocks

Resource Block

- The resource block contains physical transmitter information including available memory, manufacture identification, device type, software tag, and unique identification.

Transducer Block

- The transducer block contains the actual temperature measurement data, including sensor 1 and terminal temperature. It includes information about sensor type and configuration, engineering units, linearization, reranging, damping, temperature correction, and diagnostics.

LCD Block

- The LCD block is used to configure the local display, if an LCD Display is being used.

Analog Input (AI)

- Processes the measurement and makes it available on the fieldbus segment
- Allows filtering, alarming, and engineering unit changes.

PID Block

- The transmitter provides control functionality with one PID function block in the transmitter. The PID block can be used to perform single loop, cascade, or feedforward control in the field.

Block	Execution Time (milliseconds)
Resource	–
Transducer	–
LCD Block	–
Analog Input 1	45
Analog Input 2	45
PID 1	60

Turn-on Time

Performance within specifications in less than 20 seconds after power is applied, when damping value is set to 0 seconds.

Status

If self-diagnostics detect a sensor burnout or a transmitter failure, the status of the measurement will be updated accordingly. Status may also send the AI output to a safe value.

Power Supply

Powered over FOUNDATION fieldbus with standard fieldbus power supplies. The transmitter operates between 9.0 and 32.0 Vdc, 12 mA maximum. The power terminals are rated to 42.4 Vdc (max.).

Alarms

The AI function block allows the user to configure the alarms to HI-HI, HI, LO, or LO-LO with hysteresis settings.

Backup Link Active Scheduler (LAS)

The transmitter is classified as a device link master, which means it can function as a Link Active Scheduler (LAS) if the current link master device fails or is removed from the segment.

The host or other configuration tool is used to download the schedule for the application to the link master device. In the absence of a primary link master, the transmitter will claim the LAS and provide permanent control for the H1 segment.

FOUNDATION fieldbus Parameters

Schedule Entries	25
Links	16
Virtual Communications Relationships (VCR)	12

PROFIBUS PA SPECIFICATIONS

Function Blocks

Physical Block

- The Physical Block contains physical transmitter information including manufacturer identification, device type, software tag, and unique identification.

Transducer Block

- The Transducer Block contains the actual temperature measurement data, including sensor 1 and terminal temperature. It includes information about sensor type and configuration, engineering units, linearization, re-ranging, damping, temperature correction, and diagnostics.

Analog Input Block (AI)

- The Analog Input Block processes the measurement and makes it available on the Profibus segment. Allows filtering, alarming, and engineering unit changes.

Turn on time:

Performance within specifications in less than 20 seconds after power is applied, when damping value is set to 0 seconds.

Power Supply:

Powered over Profibus with standard fieldbus power supplies. The transmitter operates between 9.0 and 32.0 Vdc, 12 mA maximum. The power terminals are rated to 42.4 Vdc (max.)

Alarms

The AI function block allows the user to configure the alarms to HI-HI, HI, LO, or LO-LO with hysteresis settings.

4–20 mA / HART SPECIFICATIONS

Power Supply

External power supply required. Transmitters operate on 12.0 to 42.4 Vdc transmitter terminal voltage (with 250 ohm load, 18.1 Vdc power supply voltage is required). Transmitter power terminals rated to 42.4 Vdc.

Load Limitations

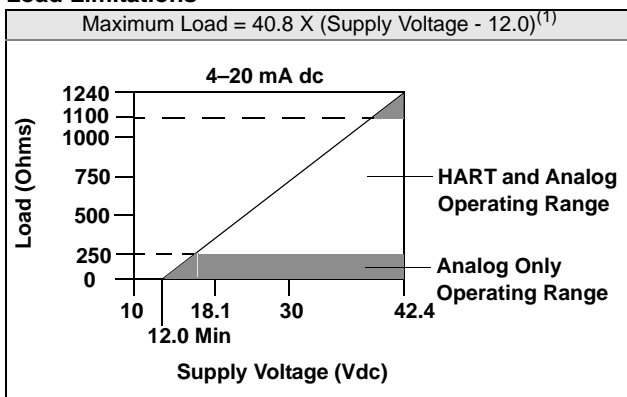

(1) Without transient protection (optional).

NOTE

HART Communication requires a loop resistance between 250 and 1100 ohms. Do not communicate with the transmitter when power is below 12 Vdc at the transmitter terminals.

Temperature Limits

	Operating Limit	Storage Limit
With LCD ⁽¹⁾	-4 to 185 °F -20 to 85 °C	-50 to 185 °F -45 to 85 °C
Without LCD	-40 to 185 °F -40 to 85 °C	-58 to 248 °F -50 to 120 °C

(1) LCD may not be readable and display updates will be slower at temperatures below -4 °F (-20 °C).

Hardware and Software Failure Mode

The 644 features software driven alarm diagnostics and an independent circuit which is designed to provide backup alarm output if the microprocessor software fails. The alarm direction (HI/LO) is user-selectable using the failure mode switch. If failure occurs, the position of the switch determines the direction in which the output is driven (HI or LO). The switch feeds into the digital-to-analog (D/A) converter, which drives the proper alarm output even if the microprocessor fails. The values at which the transmitter software drives its output in failure mode depends on whether it is configured to standard, custom, or NAMUR-compliant (NAMUR recommendation NE 43, June 1997) operation. Table 3 shows the configuration alarm ranges.

Table 3. Available Alarm Range⁽¹⁾

	Standard	NAMUR- NE 43 Compliant
Linear Output:	$3.9 \leq I^{(2)} \leq 20.5$	$3.8 \leq I \leq 20.5$
Fail High:	$21.75 \leq I \leq 23$	$21.5 \leq I \leq 23$
Fail Low:	$3.5 \leq I \leq 3.75$	$3.5 \leq I \leq 3.6$

(1) Measured in mA.

(2) I = Process Variable (current output).

Custom Alarm and Saturation Level

Custom factory configuration of alarm and saturation level is available with option code C1 for valid values. These values can also be configured in the field using a Field Communicator.

Turn-on Time

Performance within specifications in less than 5.0 seconds after power is applied, when damping value is set to 0 seconds.

Transient Protection

The Rosemount 470 prevents damage from transients induced by lightning, welding, or heavy electrical equipment. For more information, refer to the 470 Product Data Sheet (document number 00813-0100-4191).

Accuracy

Table 4. Rosemount 644 Input Options and Accuracy.

Sensor Options	Sensor Reference	Input Ranges		Recommended Min. Span ⁽¹⁾		Digital Accuracy ⁽²⁾		D/A Accuracy ⁽³⁾
		°C	°F	°C	°F	°C	°F	
2-, 3-, 4-wire RTDs								
Pt 100 ($\alpha = 0.00385$)	IEC 751	-200 to 850	-328 to 1562	10	18	± 0.15	± 0.27	±0.03% of span
Pt 200 ($\alpha = 0.00385$)	IEC 751	-200 to 850	-328 to 1562	10	18	± 0.15	± 0.27	±0.03% of span
Pt 500 ($\alpha = 0.00385$)	IEC 751	-200 to 850	-328 to 1562	10	18	± 0.19	± 0.34	±0.03% of span
Pt 1000 ($\alpha = 0.00385$)	IEC 751	-200 to 300	-328 to 572	10	18	± 0.19	± 0.34	±0.03% of span
Pt 100 ($\alpha = 0.003916$)	JIS 1604	-200 to 645	-328 to 1193	10	18	± 0.15	± 0.27	±0.03% of span
Pt 200 ($\alpha = 0.003916$)	JIS 1604	-200 to 645	-328 to 1193	10	18	± 0.27	± 0.49	±0.03% of span
Ni 120	Edison Curve No. 7	-70 to 300	-94 to 572	10	18	± 0.15	± 0.27	±0.03% of span
Cu 10	Edison Copper Winding No. 15	-50 to 250	-58 to 482	10	18	±1.40	± 2.52	±0.03% of span
Pt 50 ($\alpha = 0.00391$)	GOST 6651-94	-200 to 550	-328 to 1022	10	18	± 0.30	± 0.54	±0.03% of span
Pt 100 ($\alpha = 0.00391$)	GOST 6651-94	-200 to 550	-328 to 1022	10	18	± 0.15	± 0.27	±0.03% of span
Cu 50 ($\alpha = 0.00426$)	GOST 6651-94	-50 to 200	-58 to 392	10	18	±1.34	± 2.41	±0.03% of span
Cu 10 ($\alpha = 0.00428$)	GOST 6651-94	-185 to 200	-301 to 392	10	18	±1.34	± 2.41	±0.03% of span
Cu 10 ($\alpha = 0.00426$)	GOST 6651-94	-50 to 200	-58 to 392	10	18	±0.67	± 1.20	±0.03% of span
Cu 10 ($\alpha = 0.00428$)	GOST 6651-94	-185 to 200	-301 to 392	10	18	±0.67	± 1.20	±0.03% of span
Thermocouples ⁽⁴⁾								
Type B ⁽⁵⁾	NIST Monograph 175, IEC 584	100 to 1820	212 to 3308	25	45	± 0.77	± 1.39	±0.03% of span
Type E	NIST Monograph 175, IEC 584	-50 to 1000	-58 to 1832	25	45	± 0.20	± 0.36	±0.03% of span
Type J	NIST Monograph 175, IEC 584	-180 to 760	-292 to 1400	25	45	± 0.35	± 0.63	±0.03% of span
Type K ⁽⁶⁾	NIST Monograph 175, IEC 584	-180 to 1372	-292 to 2501	25	45	± 0.50	± 0.90	±0.03% of span
Type N	NIST Monograph 175, IEC 584	-200 to 1300	-328 to 2372	25	45	± 0.50	± 0.90	±0.03% of span
Type R	NIST Monograph 175, IEC 584	0 to 1768	32 to 3214	25	45	± 0.75	± 1.35	±0.03% of span
Type S	NIST Monograph 175, IEC 584	0 to 1768	32 to 3214	25	45	± 0.70	± 1.26	±0.03% of span
Type T	NIST Monograph 175, IEC 584	-200 to 400	-328 to 752	25	45	± 0.35	± 0.63	±0.03% of span
DIN Type L	DIN 43710	-200 to 900	-328 to 1652	25	45	± 0.35	± 0.63	±0.03% of span
DIN Type U	DIN 43710	-200 to 900	-328 to 1112	25	45	± 0.35	± 0.63	±0.03% of span
Type W5Re/W26Re	ASTM E 988-96	0 to 2000	32 to 3632	25	45	± 0.70	± 1.26	±0.03% of span
GOST Type L	GOST R 8.585-2001	-200 to 800	-328 to 1472	25	45	± 1.00	± 1.26	±0.03% of span
Other Input Types								
Millivolt Input		-10 to 100 mV				±0.015 mV		±0.03% of span
2-, 3-, 4-wire Ohm Input		0 to 2000 ohms				±0.45 ohm		±0.03% of span

- (1) No minimum or maximum span restrictions within the input ranges. Recommended minimum span will hold noise within accuracy specification with damping at zero seconds.
- (2) The published digital accuracy applies over the entire sensor input range. Digital output can be accessed by HART or FOUNDATION fieldbus Communications or Rosemount control system.
- (3) Total Analog accuracy is the sum of digital and D/A accuracies. This is not applicable for FOUNDATION fieldbus.
- (4) Total digital accuracy for thermocouple measurement: sum of digital accuracy +0.5 °C. (cold junction accuracy).
- (5) Digital accuracy for NIST Type B T/C is ±3.0 °C (±5.4 °F) from 100 to 300 °C (212 to 572 °F).
- (6) Digital accuracy for NIST Type K T/C is ±0.70 °C (±1.26 °F) from -180 to -90 °C (-292 to -130 °F).

Accuracy Example (HART devices)

When using a Pt 100 ($\alpha = 0.00385$) sensor input with a 0 to 100 °C span:

- Digital accuracy = ±0.15 °C
- D/A accuracy = ±0.03% of 100 °C or ±0.03 °C
- Total accuracy = ±0.18 °C.

Accuracy Example (FOUNDATION fieldbus and Profibus PA devices)

When using a Pt 100 ($\alpha = 0.00385$) sensor input:

- Total accuracy = ±0.15 °C.
- No D/A accuracy effects apply

Rosemount 644

Ambient Temperature Effect

Table 5. Ambient Temperature Effect

Sensor Options	Sensor Reference	Input Range (°C)	Temperature Effects per 1.0 °C (1.8 °F) Change in Ambient Temperature ⁽¹⁾	Range	D/A Effect ⁽²⁾
2-, 3-, 4-wire RTDs					
Pt 100 ($\alpha = 0.00385$)	IEC 751	-200 to 850	0.003 °C (0.0054 °F)	Entire Sensor Input Range	0.001% of span
Pt 200 ($\alpha = 0.00385$)	IEC 751	-200 to 850	0.004 °C (0.0072 °F)	Entire Sensor Input Range	0.001% of span
Pt 500 ($\alpha = 0.00385$)	IEC 751	-200 to 850	0.003 °C (0.0054 °F)	Entire Sensor Input Range	0.001% of span
Pt 1000 ($\alpha = 0.00385$)	IEC 751	-200 to 300	0.003 °C (0.0054 °F)	Entire Sensor Input Range	0.001% of span
Pt 100 ($\alpha = 0.003916$)	JIS 1604	-200 to 645	0.003 °C (0.0054 °F)	Entire Sensor Input Range	0.001% of span
Pt 200 ($\alpha = 0.003916$)	JIS 1604	-200 to 645	0.004 °C (0.0072 °F)	Entire Sensor Input Range	0.001% of span
Ni 120	Edison Curve No. 7	-70 to 300	0.003 °C (0.0054 °F)	Entire Sensor Input Range	0.001% of span
Cu 10	Edison Copper Winding No. 15	-50 to 250	0.03 °C (0.054 °F)	Entire Sensor Input Range	0.001% of span
Pt 50 ($\alpha = 0.00391$)	GOST 6651-94	-200 to 550	0.004 °C (0.0072 °F)	Entire Sensor Input Range	0.001% of span
Pt 100 ($\alpha = 0.00391$)	GOST 6651-94	-200 to 550	0.003 °C (0.0054 °F)	Entire Sensor Input Range	0.001% of span
Cu 50 ($\alpha = 0.00426$)	GOST 6651-94	-50 to 200	0.008 °C (0.0144 °F)	Entire Sensor Input Range	0.001% of span
Cu 50 ($\alpha = 0.00428$)	GOST 6651-94	-185 to 200	0.008 °C (0.0144 °F)	Entire Sensor Input Range	0.001% of span
Cu 100 ($\alpha = 0.00426$)	GOST 6651-94	-50 to 200	0.004 °C (0.0072 °F)	Entire Sensor Input Range	0.001% of span
Cu 100 ($\alpha = 0.00428$)	GOST 6651-94	-185 to 200	0.004 °C (0.0072 °F)	Entire Sensor Input Range	0.001% of span
Thermocouples					
Type B	NIST Monograph 175, IEC 584	100 to 1820	0.014 °C	$T \geq 1000$ °C	0.001% of span
			0.032 °C – (0.0025% of (T – 300))	300 °C $\leq T < 1000$ °C	0.001% of span
			0.054 °C – (0.011% of (T – 100))	100 °C $\leq T < 300$ °C	0.001% of span
Type E	NIST Monograph 175, IEC 584	-50 to 1000	0.005 °C + (0.0043% of T)	All	0.001% of span
Type J	NIST Monograph 175, IEC 584	-180 to 760	0.0054 °C + (0.00029% of T)	$T \geq 0$ °C	0.001% of span
			0.0054 °C + (0.0025% of absolute value T)	$T < 0$ °C	0.001% of span
Type K	NIST Monograph 175, IEC 584	-180 to 1372	0.0061 °C + (0.0054% of T)	$T \geq 0$ °C	0.001% of span
			0.0061 °C + (0.0025% of absolute value T)	$T < 0$ °C	0.001% of span
Type N	NIST Monograph 175, IEC 584	-200 to 1300	0.0068 °C + (0.00036% of T)	All	0.001% of span
Type R	NIST Monograph 175, IEC 584	0 to 1768	0.016 °C	$T \geq 200$ °C	0.001% of span
			0.023 °C – (0.0036% of T)	$T < 200$ °C	0.001% of span
Type S	NIST Monograph 175, IEC 584	0 to 1768	0.016 °C	$T \geq 200$ °C	0.001% of span
			0.023 °C – (0.0036% of T)	$T < 200$ °C	0.001% of span
Type T	NIST Monograph 175, IEC 584	-200 to 400	0.0064 °C	$T \geq 0$ °C	0.001% of span
			0.0064 °C + (0.0043% of absolute value T)	$T < 0$ °C	0.001% of span
DIN Type L	DIN 43710	-200 to 900	0.0054 °C + (0.00029% of T)	$T \geq 0$ °C	0.001% of span
			0.0054 °C + (0.0025% of absolute value T)	$T < 0$ °C	0.001% of span
DIN Type U	DIN 43710	-200 to 900	0.0064 °C	$T \geq 0$ °C	0.001% of span
			0.0064 °C + (0.0043% of absolute value T)	$T < 0$ °C	0.001% of span
Type W5Re/W26Re	ASTM E 988-96	0 to 2000	0.016 °C	$T \geq 200$ °C	0.001% of span
			0.023 °C – (0.0036% of T)	$T < 200$ °C	0.001% of span
GOST Type L	GOST R 8.585-2001	-200 to 800	0.007 °C	$T \geq 0$ °C	0.001% of span
			0.007 °C – (0.003% of absolute value T)	$T < 0$ °C	0.001% of span
Other Input Types					
Millivolt Input		-10 to 100 mV	0.0005 mV	Entire Sensor Input Range	0.001% of span
2-, 3-, 4-wire Ohm		0 to 2000 Ω	0.0084 Ω	Entire Sensor Input Range	0.001% of span

(1) Change in ambient is with reference to the calibration temperature of the transmitter 68 °F (20 °C) from factory.

(2) Does not apply to FOUNDATION fieldbus.

Transmitters can be installed in locations where the ambient temperature is between -40 and 85 °C (-40 and 185 °F). In order to maintain excellent accuracy performance, each transmitter is individually characterized over this ambient temperature range at the factory.

Temperature Effects Example (HART devices)

When using a Pt 100 ($\alpha = 0.00385$) sensor input with a $0-100$ °C span at 30 °C ambient temperature:

- Digital Temperature Effects: 0.003 °C \times ($30 - 20$) = 0.03 °C
- D/A Effects: $[0.001\%$ of $100]$ \times ($30 - 20$) = 0.01 °C
- Worst Case Error: Digital + D/A + Digital Temperature Effects + D/A Effects = 0.15 °C + 0.03 °C + 0.03 °C + 0.01 °C = 0.22 °C
- Total Probable Error: $\sqrt{0.15^2 + 0.03^2 + 0.03^2 + 0.01^2} = 0.16$ °C

Temperature Effects Examples (FOUNDATION fieldbus devices and Profibus PA)

When using a Pt 100 ($\alpha = 0.00385$) sensor input at 30 °C span at 30 °C ambient temperature:

- Digital Temperature Effects: 0.003 °C \times ($30 - 20$) = 0.03 °C
- D/A Effects: No D/A effects apply
- Worst Case Error: Digital + Digital Temperature Effects = 0.15 °C + 0.03 °C = 0.18 °C
- Total Probable Error: $\sqrt{0.15^2 + 0.03^2} = 0.153$ °C

Product Certifications

ROSEMOUNT 644 WITH FOUNDATION FIELDBUS AND PROFIBUS PA

Approved Manufacturing Locations

Emerson Process Management Rosemount Division. –
Chanhassen, Minnesota, USA
Rosemount Temperature GmbH – Germany
Emerson Process Management Asia Pacific – Singapore

European Union Directive Information

The EC declaration of conformity for all applicable European directives for this product can be found on the Rosemount website at www.rosemount.com. A hard copy may be obtained by contacting our local sales representative.

ATEX Directive (94/9/EC)

Rosemount Inc. complies with the ATEX Directive.

CE Electromagnetic Compatibility Compliance Testing

The 644 meets the criteria under IEC 61326:2006

Hazardous Locations Certificates

North American Certifications

Factory Mutual (FM) Approvals

- 15 FM Intrinsically Safe
Intrinsically Safe FISCO for use in Class I, II, III, Division 1, Groups A, B, C, D, E, F, and G; when installed per control drawing 00644-2075.
Temperature Code: T4A ($T_{amb} = -50$ °C to 60 °C).

Nonincendive for use in Class I, Division 2, Groups A, B, C, and D.
Temperature Code: T5 ($T_{amb} = -50$ °C to 85 °C);
T6 ($T_{amb} = -50$ °C to 70 °C)

When installed per Rosemount control drawing 00644-2075

- E5 FM Explosion Proof
Explosion Proof for Class I, Division 1, Groups B, C, and D.
Nonincendive for use in Class 1, Division 2, Groups A, B, C, and D.
Temperature Code: T5 ($T_{amb} = -50$ °C to 85 °C)
When installed per Rosemount control drawing 00644-1049
Dust Ignition Proof for Class II/III, Division 1, Groups E, F, G.
Temperature Code: T5 ($T_a = -50$ °C to 85 °C)
When installed per Rosemount drawing 00644-1049.
(J5, J6 and J8 options only.)

Canadian Standards Association (CSA) Approvals

- 16 CSA Intrinsically Safe
Intrinsically Safe and FISCO for Class I, Division 1, groups A, B, C, and D when connected per Rosemount drawing 00644-2076.
Temperature code: T4 ($T_{amb} = -50$ °C to 60 °C);
Suitable for Class I, Division 2, groups A, B, C, and D (must be installed in a suitable enclosure)

Rosemount 644

K6 CSA Intrinsically Safe, Explosion-proof
 Includes Intrinsically Safe "I6" and Explosion-Proof for Class I, Division 1, groups B, C, and D.
 Dust-Ignition Proof for Class II, Division 1, Groups E, F, and G.
 Dust-Ignition Proof for Class III, Division 1
 Seal not required.
 CSA Enclosure Type 4X

Temperature Code: T4 ($T_{amb} = -50\text{ °C to }60\text{ °C}$);
 T5 ($T_{amb} = -50\text{ °C to }85\text{ °C}$)

NOTE:
 (For J5 and J6 enclosure options only)

European Certifications

- E1 ATEX Flame-Proof
 Certificate Number: KEMA99ATEX8715X
 ATEX Marking: Ⓢ II 2 G
 CE 1180
 Ex d IIC T6 ($-40\text{ °C} \leq T_{amb} \leq 65\text{ °C}$)
 $U_i = 32\text{ Vdc}$
- Special Conditions for Safe Use (X):**
 For information on the dimensions of the flameproof joints the manufacturer shall be contacted.
- I1 ATEX Intrinsic Safety
 Certificate Number: Baseefa03ATEX0499X
 ATEX Marking: Ⓢ II 1 G
 CE 1180
 Ex ia IIC T4 ($-50\text{ °C} \leq T_{amb} \leq 60\text{ °C}$)

Table 6. Entity Parameters

I.S. Loop/Power Terminals
$U_i = 30\text{ V}$
$I_i = 300\text{ mA}$
$P_i = 1.3\text{ W}$
$C_i = 2.1\text{ nF}$
$L_i = 0$
FISCO Loop/Power Terminals
$U_i = 17.5\text{ V}$
$I_i = 380\text{ mA}$
$P_i = 5.32\text{ W}$
$C_i = 2.1\text{ nF}$
$L_i = 0$
Sensor Terminals
$U_o = 13.9\text{ V}$
$I_o = 23\text{ mA}$
$P_o = 79\text{ mW}$
$C_i = 7.7\text{ nF}$
$L_i = 0$

Special Conditions for Safe Use (X):

The apparatus must be installed in an enclosure which affords it a degree of protection of at least IP20. Non-metallic enclosures must have a surface resistance of less than $1\text{ G}\Omega$, light alloy or zirconium enclosures must be protected from impact and friction when installed.

- N1 ATEX Type n
 Certificate Number: BAS00ATEX3145
 ATEX Marking: Ⓢ II 3 G
 Ex nL IIC T5 ($-40\text{ °C} \leq T_{amb} \leq 70\text{ °C}$)
 $U_i = 32\text{ V}$
- NC ATEX Type n Component
 Certificate Number: BAS99ATEX3084U
 ATEX Marking: Ⓢ II 3 G
 Ex nL IIC T5 ($-40\text{ °C} \leq T_{amb} \leq 70\text{ °C}$)
 $U_i = 32\text{ V}$

NOTE:

The equipment must be installed in an enclosure meeting the requirements of IP54 and the requirements of the impact tests described in EN50021.

- ND ATEX Dust Ignition-Proof
 Certificate Number: KEMA99ATEX8715X
 ATEX Marking: Ⓢ II 1 D
 tD A20 T95°C ($-40\text{ °C} \leq T_{amb} \leq 85\text{ °C}$)
 CE 1180
 IP66

Special Conditions for Safe Use (X):

For information on the dimensions of the flameproof joints the manufacturer shall be contacted.

IECEX Certifications

- E7 IECEX Flameproof and Dust
 Certificate Number: IECEX KEM 09.0015X
 Ex d IIC T6 (Flameproof)
 Ex tD A20 IP 66 T 95 °C (Dust)
 $V_{max} = 32\text{ V}$

Special Conditions for Safe Use (X):

For information on the dimensions of the flameproof joints the manufacturer shall be contacted.

Table 7. Electrical Data

Transmitter	Sensor
$V_{max} = 32\text{ Vdc}$	$U_{max} = 5\text{ Vdc}$
$I_{max} = 12.0\text{ mA}$	$I_{max} = 2.0\text{ mA}$

- I7 IECEX Intrinsic Safety
 Certificate Number: IECEX BAS 07.0053X
 Ex ia IIC T4/T5/T6

Table 8. Temperature Classification

$P_i\text{ (W)}$	Temperature Class	T_{amb}
1.3	T4	$-50\text{ °C to }60\text{ °C}$
5.32 (FISCO Group IIC)	T4	$-60\text{ °C to }80\text{ °C}$

Product Data Sheet

00813-0100-4728, Rev RC

February 2012

Rosemount 644

Special Conditions for Safe Use (X):

1. The apparatus must be installed in an enclosure which affords it a degree of protection of at least IP20.
2. Non-metallic enclosures must have a surface resistance of less than 1 GΩ; light alloy or zirconium enclosures must be protected from impact and friction when installed.

Table 9. Entity Parameters

Transmitter (I.S.)	Transmitter (FISCO)	Sensor
$U_i = 30 \text{ Vdc}$	$U_i = 17.5 \text{ Vdc}$	$U_o = 13.9 \text{ Vdc}$
$I_i = 300 \text{ mA}$	$I_i = 380 \text{ mA}$	$I_o = 23 \text{ mA}$
$P_i = 1.3 \text{ W}$	$P_i = 5.32 \text{ W}$	$P_o = 79 \text{ mW}$
$C_i = 2.1 \text{ nF}$	$C_i = 2.1 \text{ nF}$	$C_i = 7.7 \text{ nF}$
$L_i = 0 \text{ mH}$	$L_i = 0 \text{ mH}$	$L_i = 0 \text{ mH}$

N7 IECEx Type n

Certificate Number: IECEx BAS 07.0055
Ex nA nL IIC T5 (-40 °C ≤ T_{amb} ≤ 70 °C)

Table 10. Electrical Data

Transmitter	Sensor	
	RTD	Thermocouple
$U_i = 32 \text{ V}$	$U_i = 5 \text{ V}$	$U_i = 0$

NG IECEx Type n Component

Certificate Number: IECEx BAS 07.0054U
Ex nA nL IIC T5 (-40 °C ≤ T_{amb} ≤ 75 °C)
Input Parameter: $U_i = 32 \text{ Vdc}$

Schedule of Limitations:

The component must be housed in a suitably certified enclosure that provides a degree of protection of at least IP54.

Japanese Certifications

Japanese Industrial Standard (JIS) Approvals

I4 JIS Intrinsic Safety

E4 JIS Explosion Proof

Table 11. Certificate and Description

Certificate	Description	Approval Group	Temp Code
C15911	644H with meter and thermocouple	Ex d II B + H2	T4
C15912	644H without meter and with RTD	Ex d II B + H2	T4
C15913	644H with meter and RTD	Ex d II B + H2	T4

Combination Approvals

K5 Combination of I5 and E5.

Russian GOST Certifications

PPC BA-13006:

0 Ex ia IIC T4/T5/T6

Kazakhstan GOST

Pattern approval Certificate for Measuring Instruments

See Certificate

Ukraine GOST

Pattern Approval for Measuring Instruments

See Certificate

ROSEMOUNT 644 WITH HART

Approved Manufacturing Locations

Emerson Process Management Rosemount Division. – Chanhassen, Minnesota, USA

Rosemount Temperature GmbH – Germany

Emerson Process Management Asia Pacific – Singapore

European Union Directive Information

The EC declaration of conformity for all applicable European directives for this product can be found on the Rosemount website at www.rosemount.com. A hard copy may be obtained by contacting our local sales representative.

ATEX Directive (94/9/EC)

Rosemount Inc. complies with the ATEX Directive.

CE Electromagnetic Compatibility Compliance Testing

The 644 meets the criteria under IEC 61326:2006

Table 11. Certificate and Description

Certificate	Description	Approval Group	Temp Code
C15744	644H with meter and no sensor	Ex d II C	T6
C15745	644H without meter and no sensor	Ex d II C	T6
C15749	644H without meter and with RTD	Ex d II B	T4
C15750	644H without meter and with thermocouple	Ex d II B	T4
C15751	644H with meter and thermocouple	Ex d II B	T4
C15752	644H with meter and RTD	Ex d II B	T4
C15910	644H without meter and with thermocouple	Ex d II B + H2	T4

Hazardous Locations Certificates

North American Certifications

Factory Mutual (FM) Approvals

- I5 FM Intrinsically Safe and Non-incendive
Intrinsically Safe for Class I/II/III, Division 1, Groups A, B, C, D, E, F, and G.
Non-incendive for Class I, Division 2, Groups A, B, C, and D.
Temperature Code: T5 ($T_a = -50\text{ °C}$ to 85 °C)
When installed in accordance with Rosemount drawing 00644-0009.

Table 12. Temperature Code

Pi	Temperature Code
0.67 W	T5 ($T_{amb} = -50\text{ °C}$ to 50 °C)
0.67 W	T6 ($T_{amb} = -50\text{ °C}$ to 40 °C)
1.0 W	T4 ($T_{amb} = -50\text{ °C}$ to 80 °C)
1.0 W	T5 ($T_{amb} = -50\text{ °C}$ to 40 °C)

- E5 FM Explosion Proof
Explosion Proof for Class I, Division 1, Groups B, C, and D.
Nonincendive for use in Class 1, Division 2, Groups A, B, C, and D.
Temperature Code: T5 ($T_{amb} = -50\text{ °C}$ to 85 °C)
When installed per Rosemount control drawing 00644-1049
Dust Ignition Proof for Class II/III, Division 1, Groups E, F, G.
Temperature Code: T5 ($T_a = -50\text{ °C}$ to 85 °C)
When installed per Rosemount drawing 00644-1049.
(J5, J6 and J8 options only.)

- K5 Combination of I5 and E5.

NOTE

K5 is only available with 644H option code J6.

Canadian Standards Association (CSA) Approvals

- I6 CSA Intrinsically Safe
Intrinsically Safe for Class I, Division 1, Groups A, B, C, and D when installed in accordance with Rosemount drawing 00644-1064.

Table 13. Temperature Code

Pi	Temperature Code
0.67 W	T6 ($T_{amb} = -50\text{ °C}$ to 40 °C)
0.67 W	T5 ($T_{amb} = -50\text{ °C}$ to 60 °C)
1.0 W	T4 ($T_{amb} = -50\text{ °C}$ to 80 °C)

- K6 CSA Intrinsically Safe, Explosion-Proof, and Non-incendive
Combination of I6 and Explosion-proof for Class I, Division 1, Groups B, C, and D; Dust-ignition proof for Class II, Division 1, Groups E, F, and G; Class III, Division 1 hazardous locations, when installed in accordance with Rosemount drawing 00644-1059.
Suitable for Class I, Division 2, Groups B, C, and D when installed in a suitable enclosure.
Temperature Code: Ambient Limits -50 °C to 85 °C .

NOTE

K6 is only available with 644H option code J6.

European Certifications

- I1 ATEX Intrinsic Safety
Certificate Number: BAS00ATEX1033X
ATEX Marking: Ex II 1 G Ex ia IIC T4/T5/T6
CE 1180

Table 14. Temperature Code

Pi	Temperature Code
0.67 W	T6 ($-60\text{ °C} \leq T_{amb} \leq 40\text{ °C}$)
0.67 W	T5 ($-60\text{ °C} \leq T_{amb} \leq 50\text{ °C}$)
1.0 W	T5 ($-60\text{ °C} \leq T_{amb} \leq 40\text{ °C}$)
1.0 W	T4 ($-60\text{ °C} \leq T_{amb} \leq 80\text{ °C}$)

Table 15. Entity Parameters

Loop/Power	Sensor
$U_i = 30\text{ V}$	$U_o = 13.6\text{ V}$
$I_i = 200\text{ mA}$	$I_o = 80\text{ mA}$
$P_i = 0.67\text{ W}$ or 1.0 W	$P_o = 80\text{ mW}$
$C_i = 10\text{ nF}$	$C_i = 75\text{ nF}$
$L_i = 0$	$L_i = 0$

Special Conditions for Safe Use (X):

The transmitter must be installed so that its external terminals and communication pins are protected to at least IP20.
Non-metallic enclosures must have a surface resistance of less than $1\text{ G}\Omega$. Light alloy or zirconium enclosures must be protected from impact and friction when installed.

- E1 ATEX Flame-Proof
Certificate Number: KEMA99ATEX8715X
ATEX Marking: Ex II 2 G Ex d IIC T6
CE 1180
Temperature Code: T6 ($-40\text{ °C} \leq T_{amb} \leq 65\text{ °C}$)
Max Input Voltage: $U_i = 42.4\text{ Vdc}$

Special Conditions for Safe Use (X):

For information on the dimensions of the flameproof joints the manufacturer shall be contacted.

- N1 ATEX Type n
Certificate Number: BAS00ATEX3145
ATEX Marking: Ex II 3 G Ex nL IIC T5
Temperature Code: T5 ($-40\text{ °C} \leq T_{amb} \leq 70\text{ °C}$)
Max Input Voltage: $U_i = 42.4\text{ Vdc}$

- NC ATEX Type n Component
Certificate Number: BAS99ATEX3084U
ATEX Marking: Ex II 3 G Ex nL IIC T5
Temperature Code: T5 ($-40\text{ °C} \leq T_{amb} \leq 70\text{ °C}$)
Max Input Voltage: $U_i = 42.4\text{ Vdc}$

NOTE

The equipment must be installed in an enclosure meeting the requirements of IP54 and the requirements of the impact tests described in EN50021.

- ND ATEX Dust Ignition-Proof
Certificate Number: KEMA99ATEX8715X
ATEX Marking: Ex II 1 D
tD A20 T95 C ($-40\text{ °C} = T_{amb} = +85\text{ °C}$)
IP 66

Product Data Sheet

00813-0100-4728, Rev RC

February 2012

Rosemount 644

Special Conditions for Safe Use (X):

For information on the dimensions of the flameproof joints the manufacturer shall be contacted.

IECEX Certifications

- E7 IECEX Flameproof and Dust
 Certificate Number: IECEX KEM 09.0015X
 Ex d IIC T6 (Flameproof)
 Ex tD A20 IP 66 T 95 °C (Dust)
 Vmax = 42.4 V

Special Conditions for Safe Use (X):

For information on the dimensions of the flameproof joints the manufacturer shall be contacted.

Table 16. Electrical Data

Transmitter	Sensor
U _{max} = 42.4 Vdc	U _{max} = 5 Vdc
I _{max} = 24.0 mA	I _{max} = 2.0 mA

- I7 IECEX Intrinsic Safety
 Certificate Number: IECEX BAS 07.0053X
 Ex ia IIC T4/T5/T6

Table 17. Temperature Classification

P _i (w)	Temperature Class	T _{amb}
0.67	T6	-60 °C to 40 °C
0.67	T5	-60 °C to 50 °C
1.0	T5	-60 °C to 40 °C
1.0	T4	-60 °C to 80 °C

Special Conditions for Safe Use (X):

- The apparatus must be installed in an enclosure which affords it a degree of protection of at least IP20.
- Non-metallic enclosures must have a surface resistance of less than 1 GΩ; light alloy or zirconium enclosures must be protected from impact and friction when installed.

Table 18. Entity Parameters

Transmitter	Sensor
U _i = 30 Vdc	U _o = 13.6 Vdc
I _i = 200 mA	I _o = 80 mA
P _i = 0.67 W or 1.0 W	P _o = 80 mW
C _i = 10 nF	C _i = 75 nF
L _i = 0 mH	L _i = 0 mH

- N7 IECEX Type n
 Certificate Number: IECEX BAS 07.0055
 Ex nA nL IIC T5 (-40 °C ≤ T_{amb} ≤ 70 °C)

Table 19. Electrical Data

Transmitter	Sensor	
	RTD	Thermocouple
U _i = 42.4 V	U _i = 5 V	U _i = 0

- NG IECEX Type n Component
 Certificate Number: IECEX BAS 07.0054U
 Ex nA nL IIC T5 (-40 °C ≤ T_{amb} ≤ 75 °C)
 Input Parameter: U_i = 42.4 Vdc

Schedule of Limitations:

The component must be housed in a suitably certified enclosure that provides a degree of protection of at least IP54.

Brazilian Certifications

Centro de Pesquisas de Energia Eletrica (CEPEL)
 Approval

- I2 CEPEL Intrinsic Safety. Not available, consult factory

Russian Certifications

Gostandart

Tested and approved by the Russian Metrological Institute GOSTANDART.

Japanese Certifications

Japanese Industrial Standard (JIS) Approvals

- E4 JIS Explosion-Proof

Table 20. Certificate and Description

Certificate	Description	Approval Group	Temp Code
C15744	644H with meter and no sensor	Ex d II C	T6
C15745	644H without meter and no sensor	Ex d II C	T6
C15749	644H without meter and with RTD	Ex d II B	T4
C15750	644H without meter and with thermocouple	Ex d II B	T4
C15751	644H with meter and thermocouple	Ex d II B	T4
C15752	644H with meter and RTD	Ex d II B	T4
C15910	644H without meter and with thermocouple	Ex d II B + H2	T4
C15911	644H with meter and thermocouple	Ex d II B + H2	T4
C15912	644H without meter and with RTD	Ex d II B + H2	T4
C15913	644H with meter and RTD	Ex d II B + H2	T4

NOTE

Explosion Proof certification is only available as a complete assembly with Rosemount universal head – option codes J5, J6, J7, and J8.

Slovak Republic Certification

- Ex ia IIC T4 & T5
 See Intrinsic Safety Certificate

Dimensional Drawings

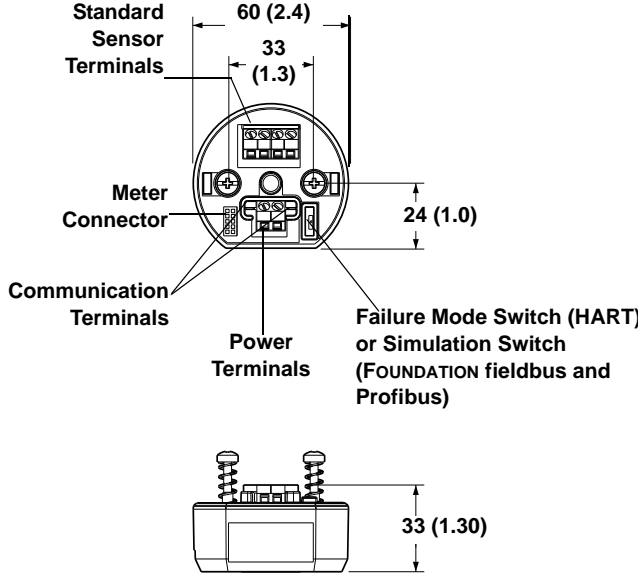
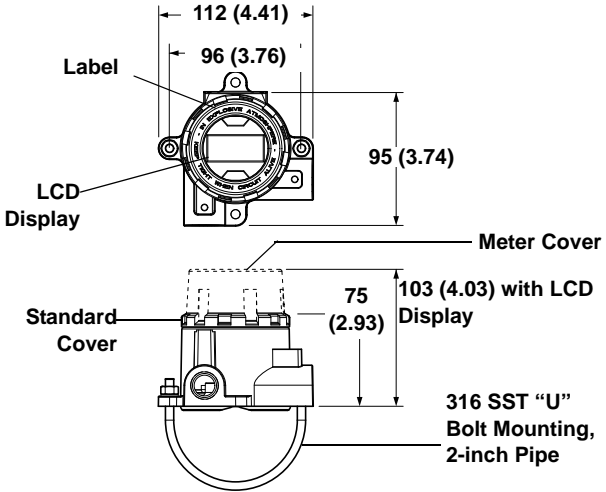
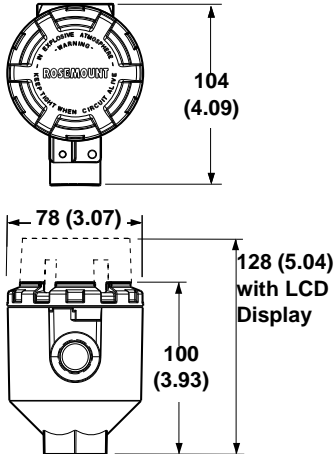
644H (DIN A Head Mount)	
Shown with Standard Compression Screw Terminals	
	
Threaded-Sensor Universal Head (Option code J5, J6, J7 or J8)	Integral DIN Style Sensor Connection Head (see Sensor PDS for ordering options)
	
<p><i>Note: A "U" Bolt is shipped with each universal head unless assembly option XA is ordered. Since the head is integrally mounted to the sensor, it may not need to be used.</i></p>	<p><i>Note: If ordering the transmitter with a DIN style sensor, it is required that the enclosure be ordered within the Sensor Model (Product Data Sheet doc # 00813-0200-2654) rather than within the transmitter model, this is in order to drive necessary parts.</i></p>
<p>Dimensions are in millimeters (inches)</p>	

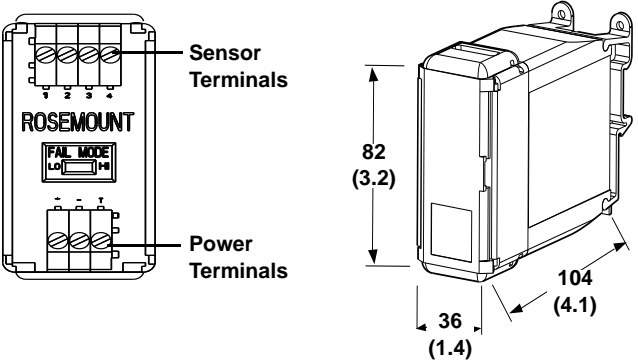
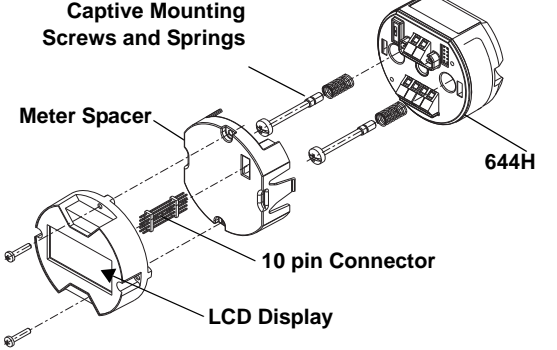
644 Rail Mount	644H with LCD Display
 <p>Sensor Terminals</p> <p>ROSEMOUNT</p> <p>Power Terminals</p> <p>82 (3.2)</p> <p>104 (4.1)</p> <p>36 (1.4)</p>	 <p>Captive Mounting Screws and Springs</p> <p>Meter Spacer</p> <p>644H</p> <p>10 pin Connector</p> <p>LCD Display</p>

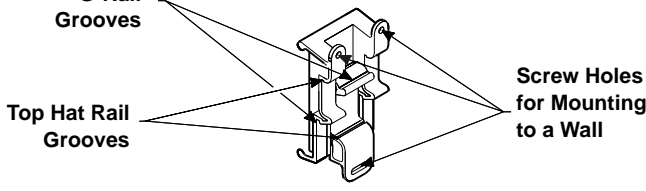
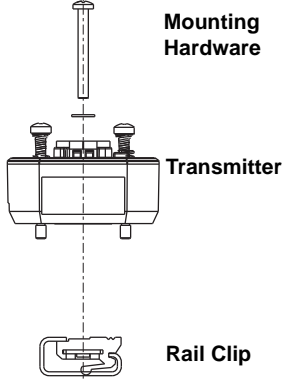
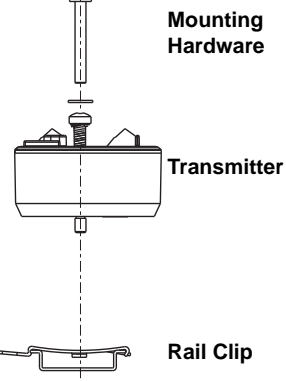
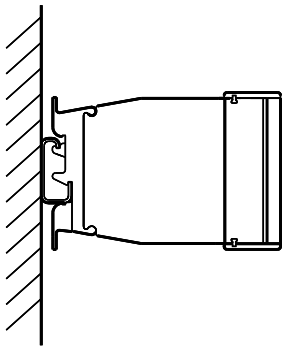
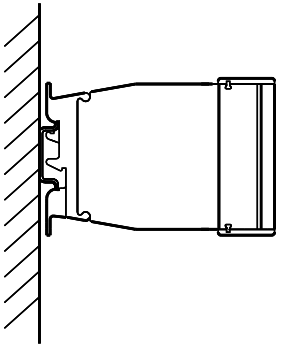
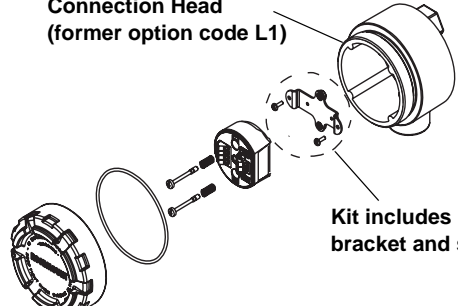
Mounting Kits for both 644H and 644R		
644R Rail & Walls Clips	644H Rail Clips	
	G-Rail (asymmetric)	Top Hat Rail (symmetric)
 <p>G-Rail Grooves</p> <p>Top Hat Rail Grooves</p> <p>Screw Holes for Mounting to a Wall</p>	 <p>Mounting Hardware</p> <p>Transmitter</p> <p>Rail Clip</p>	 <p>Mounting Hardware</p> <p>Transmitter</p> <p>Rail Clip</p>
		<p>Note: Kit (part number 00644-5301-0010) includes mounting hardware and both types of rail kits.</p>
<p style="text-align: center;">644H Retrofit Kit</p>		
 <p>Existing Threaded Sensor Connection Head (former option code L1)</p> <p>Kit includes replacement bracket and screws.</p>		
<p>(part number 03044-4103-0001)</p> <p>Note: Kit (part number 00644-5321-0010) includes a new mounting bracket and the hardware necessary to facilitate the installation.</p>		

STAINLESS STEEL HOUSING FOR BIOTECHNOLOGY, PHARMACEUTICAL INDUSTRIES, AND SANITARY APPLICATIONS

LCD Display Cover

- 316L SST
- Glass

Dimensional Drawings

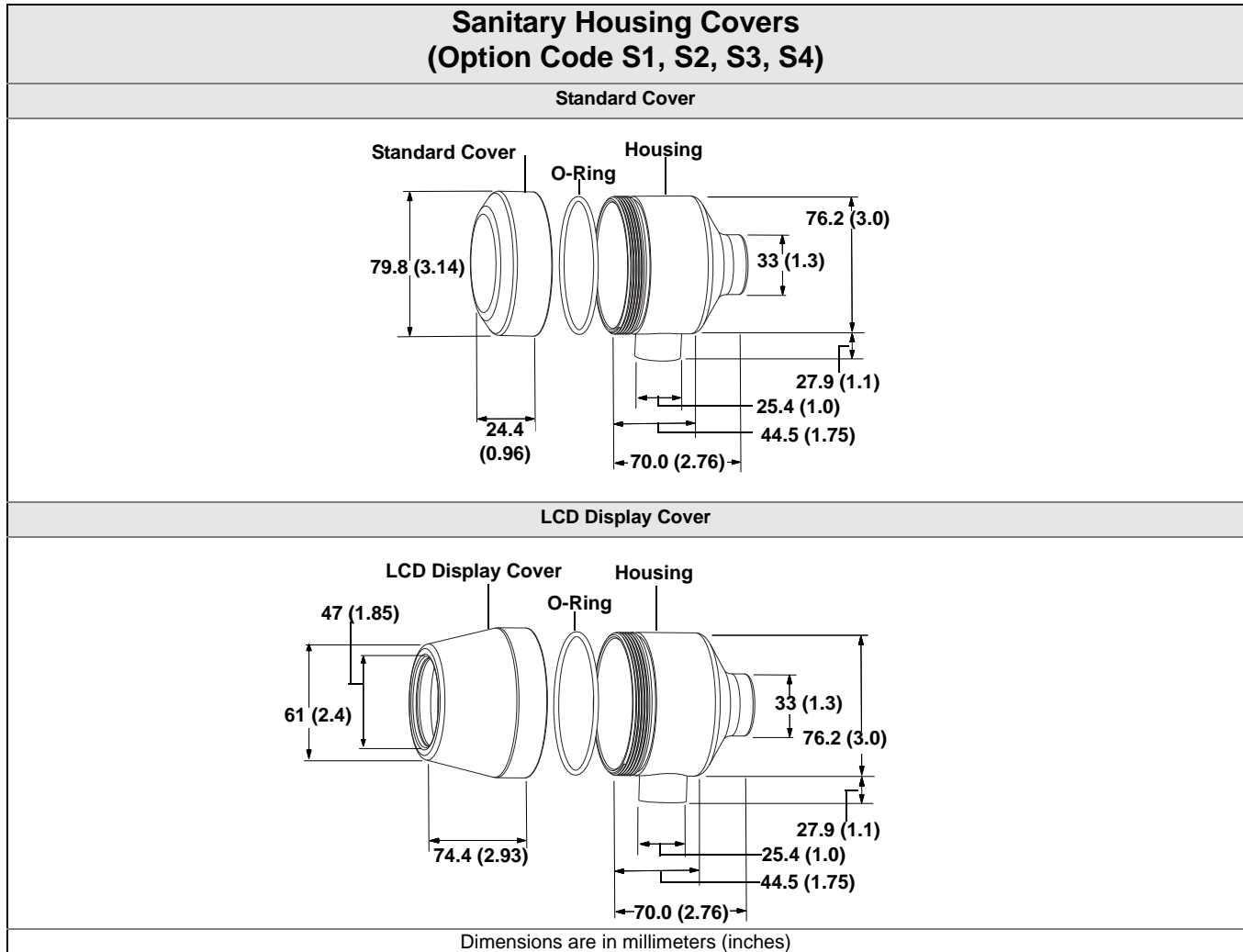

Configuration

Transmitter Configuration

The transmitter is available with standard configuration setting for either HART, FOUNDATION fieldbus (see Standard Foundation fieldbus Configuration) or Profibus PA (see Standard Profibus PA Configuration). The configuration settings and block configuration may be changed in the field with Emerson's DeltaV[®], AMS[™] Suite, Handheld Field Communicator or other host or configuration tool.

Standard HART Configuration

Unless specified, the transmitter will be shipped as follows:

Sensor Type	RTD, Pt 100 ($\alpha=0.00385$, 4-wire)
4 mA Value	0 °C
20 mA Value	100 °C
Output	Linear with temperature
Saturation Levels	3.9 / 20.5 mA
Damping	5 sec.
Line Voltage Filter	50 Hz
Alarm	High (21.75 mA)
LCD (when installed)	Engineering Units and mA
Tag	See "Tagging" on page 7

Standard FOUNDATION fieldbus Configuration

Unless otherwise specified, the transmitter will be shipped as follows:

Sensor Type: RTD, Pt 100 ($\alpha=0.00385$, 4-wire)
Damping: 5 sec.
Units of Measurement: °C
Line Voltage Filter: 50 Hz
Software Tag: See Tagging
Function Blocks Tags: <ul style="list-style-type: none"> Resource Block: Resource Transducer Block: Transducer LCD Block: LCD Analog Input Blocks: AI 1300, AI 1400 PID Block: PID 1500
Alarm Limits of AI 1300, AI 1400 <ul style="list-style-type: none"> HI-HI: Infinity HI: Infinity LO: Infinity LO-LO: Infinity
Local Display (when installed): Engineering Units of Temperature

Standard Block Configuration

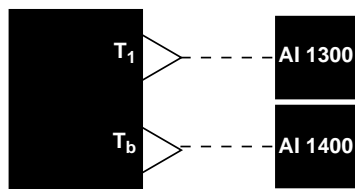

Note:
 T_1 = Sensor Temperature
 T_b = Terminal Temperature

Final Station

AI Blocks are scheduled for 1 second. AI Blocks are linked as shown above.

Standard Profibus PA Configuration

Unless specified, the transmitter will be shipped as follows:

Device Address: 126
Sensor Type: RTD, Pt 100 ($\alpha=0.00385$, 4-wire)
Damping: 5 sec.
Units of Measurement: °C
Line Voltage Filter: 50 Hz
Software Tag: See Tagging
Alarm Limits: <ul style="list-style-type: none"> HI-HI: Infinity HI: Infinity LO: - Infinity LO-LO: Infinity
Local Display (when installed): Engineering Units of Temperature

Custom Configuration

Custom configurations are to be specified when ordering. The following tables list the descriptions and elements necessary to specify a custom configuration.

	Option Code	Requirements/ Specification
HART	C1: Factory Configuration Data (CDS required)	Date: day/month/year Descriptor: 8 alphanumeric characters Message: 32 alphanumeric characters Analog Output: Alarm and saturation levels.
	C2: Transmitter – Sensor Matching	The transmitters are designed to accept Callendar-Van Dusen constants from a calibrated RTD. Using these constants, the transmitter generates a custom curve to match the sensor-specific curve. Specify a Series 65, 65, or 78 RTD sensor on the order with a special characterization curve (V or X8Q4 option). These constants will be programmed into the transmitter with this option.
	C4: Five-Point Calibration	Will include five-point calibration at 0, 25, 50, 75, and 100% analog and digital output points. Use with Calibration Certificate Q4.
	Q4: Three-Point Calibration with Certificate	Calibration certificate. <i>Three-Point calibration with certificate.</i>

Product Data Sheet

00813-0100-4728, Rev RC

February 2012

Rosemount 644

	Option Code	Requirements/ Specification
FOUNDATION fieldbus	C1: Factory Configuration Data (CDS required)	Date: day/month/year Descriptor: 16 alphanumeric characters Message: 32 alphanumeric characters
	C2: Transmitter – Sensor Matching	The transmitters are designed to accept Callendar-Van Dusen constants from a calibrated RTD. Using these constants, the transmitter generates a custom curve to match the sensor-specific curve. Specify a Series 65, 65, or 78 RTD sensor on the order with a special characterization curve (V or X8Q4 option). These constants will be programmed into the transmitter with this option.
	C4: Five-Point Calibration	Will include five-point calibration at 0, 25, 50, 75, and 100% analog and digital output points. Use with Calibration Certificate Q4.
	Q4: Three-Point Calibration with Certificate	Calibration certificate. <i>Three-Point calibration with certificate.</i>

	Option Code	Requirements/ Specification
Profibus PA	C1: Factory Configuration Data (CDS required)	Date: day/month/year Descriptor: 16 alphanumeric characters Message: 32 alphanumeric characters
	C2: Transmitter – Sensor Matching	The transmitters are designed to accept Callendar-Van Dusen constants from a calibrated RTD. Using these constants, the transmitter generates a custom curve to match the sensor-specific curve. Specify a Series 65, 65, or 78 RTD sensor on the order with a special characterization curve (V or X8Q4 option). These constants will be programmed into the transmitter with this option.
	C4: Five-Point Calibration	Will include five-point calibration at 0, 25, 50, 75, and 100% analog and digital output points. Use with Calibration Certificate Q4.
	Q4: Three-Point Calibration with Certificate	Calibration certificate. <i>Three-Point calibration with certificate.</i>

Standard Terms and Conditions of Sale can be found at www.rosemount.com/terms_of_sale

The Emerson logo is a trademark and service mark of Emerson Electric Co.

Rosemount and the Rosemount logotype are registered trademarks of Rosemount Inc.

FOUNDATION is a trademark of the Fieldbus Foundation.

HART is a registered trademark of the HART Communication Foundation.

Eurofast and Minifast are registered trademarks of Turck Inc.

The 3-A symbol is a registered trademark of the 3-A Sanitary Standards Symbol Council.

Noryl is a registered trademark of General Electric.

Lexan is a registered trademark of General Electric.

All other marks are the property of their respective owners.

© 2012 Rosemount, Inc. All rights reserved.

**Emerson Process Management
Rosemount Measurement**
8200 Market Boulevard
Chanassen MN 55317 USA
Tel (USA) 1 800 999 9307
Tel (International) +1 952 906 8888
Fax +1 952 906 8889

Emerson Process Management
Blegistrasse 23
P.O. Box 1046
CH 6341 Baar
Switzerland
Tel +41 (0) 41 768 6111
Fax +41 (0) 41 768 6300

Emerson FZE
P.O. Box 17033
Jebel Ali Free Zone
Dubai UAE
Tel +971 4 811 8100
Fax +971 4 886 5465

**Emerson Process Management Asia Pacific
Pte Ltd**
1 Pandan Crescent
Singapore 128461
Tel +65 6777 8211
Fax +65 6777 0947
Service Support Hotline : +65 6770 8711
Email : Enquiries@AP.EmersonProcess.com