

DVC6000f Series FIELDVUE® Digital Valve Controllers

DVC6000f Series digital valve controllers for FOUNDATION™ fieldbus are interoperable, communicating, microprocessor-based, digital-to-pneumatic instruments. In addition to the primary function of converting a digital input signal to a pneumatic output, the DVC6000f Series digital valve controller, using FOUNDATION fieldbus communications protocol, gives easy access to information critical to process operation as well as process control. This can be done using a DeltaV™ console, another FOUNDATION fieldbus system console, or with AMS™ ValveLink® Software.

DVC6000f Series digital valve controllers can be mounted on sliding-stem actuators, as shown in figure 1, or on rotary actuators, as shown in figure 2. DVC6000f Series digital valve controllers mount on most Fisher® actuators, as well as other manufacturers' rotary and sliding-stem actuators.

In new or existing installations, the DVC6000f Series digital valve controller's two-wire design avoids the high cost of running separate power and signal wiring by allowing you to use the existing wiring. FOUNDATION fieldbus allows multiple instruments to operate on a two-wire pair, thus reducing overall installation costs.

Note

Neither Emerson, Emerson Process Management, nor any of their affiliated entities assumes responsibility for the selection, use, and maintenance of any product. Responsibility for the selection, use, and maintenance of any product remains with the purchaser and end-user.



WB132-1

Figure 1. Type DVC6010f Digital Valve Controller Mounted on Type 585C Piston Actuator



WB115-FF

Figure 2. Rotary Control Valve with Type DVC6020f Digital Valve Controller



Specifications

Available Configurations

- Type DVC6010f:** Sliding stem applications
- Type DVC6020f:** Rotary and long-stroke sliding-stem applications [over 102 mm (4-inch) travel]
- Type DVC6030f:** Quarter-turn rotary applications

Remote-Mounted Instrument⁽¹⁾

- DVC6005f:** Base unit for 2-inch pipestand or wall mounting
 - DVC6015:** Feedback unit for sliding-stem applications
 - DVC6025:** Feedback unit for rotary or long-stroke sliding-stem applications
 - DVC6035:** Feedback unit for quarter-turn rotary applications
- DVC6000f Series digital valve controllers can be mounted on Fisher and other manufacturers' rotary and sliding-stem actuators.

Function Block Suites

- Standard Control (throttling control)
Includes AO, PID, ISEL, OS, AI, MAI, DO, and four DI function blocks
- Fieldbus Control (throttling control)
AO function block
- Fieldbus Logic [discrete (on/off) connectivity]
Includes DO, and four DI function blocks

Block Execution Times

- | | |
|--------------------------|-------------------------|
| <i>AO Block:</i> 25 ms | <i>AI Block:</i> 25 ms |
| <i>PID Block:</i> 30 ms | <i>MAI BLock:</i> 40 ms |
| <i>ISEL Block:</i> 25 ms | <i>DO Block:</i> 25 ms |
| <i>OS Block:</i> 25 ms | <i>DI Block:</i> 20 ms |

Electrical Input

- Voltage Level:** 9 to 32 volts
- Maximum Current:** 18 mA
- Reverse Polarity Protection:** Unit is not polarity sensitive
- Termination:** Bus must be properly terminated per ISA SP50 guidelines

Digital Communication Protocol

- FOUNDATION fieldbus registered device
- Physical Layer Type(s):

121—Low-power signaling, bus-powered, Entity Model I.S.

511—Low-power signaling, bus-powered, FISCO I.S.

Output Signal⁽²⁾

Pneumatic signal as required by the actuator, up to full supply pressure.

Minimum Span: 0.4 bar (6 psig)

Maximum Span: 9.5 bar (140 psig)

Action: Double, Single direct, and Single reverse

Supply Pressure^(2,6)

Recommended: 0.3 bar (5 psi) higher than maximum actuator requirements, up to maximum supply pressure

Maximum: 10 bar (145 psig) or maximum pressure rating of the actuator, whichever is lower

Steady-State Air Consumption^(2,3,4)

Standard Relay: At 1.4 bar (20 psig) supply pressure: Less than 0.38 normal m³/hr (14 scfh)
At 5.5 bar (80 psig) supply pressure: Less than 1.3 normal m³/hr (49 scfh)

Low Bleed Relay: At 1.4 bar (20 psig) supply pressure: Average value 0.056 normal m³/hr (2.1 scfh)
At 5.5 bar (80 psig) supply pressure: Average value 0.184 normal m³/hr (6.9 scfh)

Maximum Output Capacity^(3,4)

At 1.4 bar (20 psig) supply pressure: 10.0 normal m³/hr (375 scfh)
At 5.5 bar (80 psig) supply pressure: 29.5 normal m³/hr (1100 scfh)

Independent Linearity^(2,5)

±0.50% of output span

Electromagnetic Interference (EMI)

Tested per IEC 61326-1 (Edition 1.1). Complies with European EMC Directive. Meets emission levels for Class A equipment (industrial locations) and Class B equipment (domestic locations). Meets immunity requirements for industrial locations (Table A.1 in the IEC specification document). Immunity performance is shown in table 1.

–continued–

Product Bulletin

62.1:DVC6000f
March 2007

DVC6000f Digital Valve Controllers

Specifications (continued)

Operating Ambient Temperature Limits⁽⁶⁾

- 40 to 80°C (-40 to 176°F) for most approved valve-mounted instruments.
- 40 to 125°C (-40 to 257°F) for remote-mounted feedback units.
- 52 to 80°C (-62 to 176°F) for valve-mounted instruments utilizing the Extreme Temperature option (fluorosilicone elastomers)

Electrical Classification



Explosion proof, Division 2, Dust-Ignition proof, Intrinsic Safety



Explosion proof, Non-incendive, Dust-Ignition proof, Intrinsic Safety

ATEX Flameproof, Type n, Intrinsic Safety

IECEx Flameproof, Type n, Intrinsic Safety

Refer to tables 3, 4, 5, and 6 for specific approval information

Electrical Housing: NEMA 4X, CSA Type 4X, IEC 60529 IP66

Connections

Supply Pressure: 1/4 NPT internal and integral pad for mounting 67CFR regulator

Output Pressure: 1/4 NPT internal

Tubing: 3/8-inch metal, recommended

Vent: 3/8 NPT internal

Electrical: 1/2 NPT internal, M20 adapter optional

Stem Travel

DVC6010f, DVC6015: 0 to 102 mm (4-inches) maximum
0 to 9.5 mm (0.375 inches) minimum

DVC6020f, DVC6025: 0 to 606 mm (23.875 inches) maximum

Shaft Rotation (DVC6020f, DVC6025, DVC6030f and DVC6035)

0 to 50 degrees minimum

0 to 90 degrees maximum

Mounting

Designed for direct actuator mounting or remote pipestand or wall mounting. Mounting the instrument vertically, with the vent at the bottom of the assembly, or horizontally, with the vent pointing down, is recommended to allow drainage of moisture that may be introduced via the instrument air supply.

Weight

Valve-Mounted Instruments

Aluminum: 3.5 Kg (7.7 lbs)

Stainless Steel: 7.7 Kg (17 lbs)

Remote-Mounted Instruments

DVC6005f Base Unit: 4.1 Kg (9 lbs)

DVC6015 Feedback Unit: 1.3 Kg (2.9 lbs)

DVC6025 Feedback Unit: 1.4 Kg (3.1 lbs)

DVC6035 Feedback Unit: 0.9 Kg (2.0 lbs)

Options

- Supply and output pressure gauges or ■ Tire valves, ■ Integral mounted filter regulator, ■ Stainless steel housing, module base and terminal box (valve-mounted instruments only)
- *Function Block Suite:* Standard Control, Fieldbus Control or Fieldbus Logic
- *Diagnostic Level:* Performance Diagnostics, Advanced Diagnostics or Fieldbus Diagnostics

1. 3-conductor shielded cable, 22 AWG minimum wire size, is recommended for connection between base unit and feedback unit. Pneumatic tubing between base unit output connection and actuator has been tested to 15 meters (50 feet) maximum without performance degradation.
 2. Defined in ISA Standard S51.1.
 3. Normal m³/hour – Normal cubic meters per hour at 0°C and 1.01325 bar, absolute. Scfh – Standard cubic feet per hour at 60°F and 14.7 psia.
 4. Values at 1.4 bar (20 psig) based on a single-acting direct relay; values at 5.5 bar (80 psig) based on double-acting relay.
 5. Typical value. Not applicable for travels less than 19 mm (0.75 inch) or for shaft rotation less than 60 degrees. Also, not applicable to Type DVC6020f digital valve controllers in long-stroke applications.
 6. The pressure/temperature limits in this document and any applicable code or standard should not be exceeded.

Table 1. Immunity Performance

Port	Phenomenon	Basic Standard	Performance Criteria ⁽¹⁾
Enclosure	Electrostatic discharge (ESD)	IEC 61000-4-2	A
	Radiated EM field	IEC 61000-4-3	A
	Rated power frequency magnetic field	IEC 61000-4-8	A
I/O signal/control	Burst	IEC 61000-4-4	A
	Surge	IEC 61000-4-5	A
	Conducted RF	IEC 61000-4-6	A

1. A = No degradation during testing. B = Temporary degradation during testing, but is self-recovering.

DVC6000f Digital Valve Controllers

Features

- **EDD Availability**—An extended device description is available for the DVC6000f digital valve controller. Using this file, any EDD compatible host can provide graphic user interface to the DVC6000f configuration, calibration, and diagnostic capabilities.

- **Improved Control**—Two-way digital communications give you current valve conditions. You can use this real-time information to make sound process management decisions. By analyzing valve dynamics through AMS ValveLink Software you can identify control areas needing improvement and maintain a high level of system performance.

- **Valve and Actuator Data at your Fingertips**—Accurate information is the key to valve diagnostics. Valve and actuator spec sheet data for diagnostic use are embedded in the DVC6000f instrument during factory mounting, providing up-to-date and accurate information.

- **Enhanced Safety**—You can check instrument and valve operation and keep the process running smoothly and safely from a remote location. Access is possible at a field junction box, marshalling panel, or within the safety of the control room using either a 375 Field Communicator, personal computer, or a system workstation. Your exposure to hazardous environments is minimized and you can avoid having to access hard-to-reach valve locations.

- **Hardware Savings**—DVC6000f Series digital valve controllers, when used in an integrated system, allow you to realize significant hardware and installation cost savings by replacing other devices in the process loop, such as positioners and limit switches, with a FIELDVUE digital valve controller.

- **Travel Control-Pressure Fallback**—Valve position feedback is critical to the operation of a digital valve controller. Without this feedback, the control valve assembly traditionally goes to its fail safe position. The DVC6000f Series digital valve controller can detect position feedback problems caused by a travel sensor failure or linkage failure and continue to operate in “pressure control” mode.

If a problem with the valve position feedback is detected, the instrument will automatically disable the travel sensor, send an alert, and control its output pressure much like a fieldbus-to-pressure transducer. This allows the valve assembly to continue to operate with reduced accuracy until maintenance can be scheduled.

- **Built to Survive**—Field-tough DVC6000f Series digital valve controllers have fully encapsulated printed wiring boards that resist the effects of vibration, temperature, and corrosive atmospheres. A separate weather-tight field wiring terminal box isolates field-wiring connections from other areas of the instrument. Optional stainless steel, remote mount, and extreme temperature constructions provide added durability to any application need.

- **Increased Uptime**—With the self-diagnostic capability of DVC6000f Series digital valve controllers, you can answer questions about a valve’s performance, without pulling the valve from the line. Diagnostics that evaluate the health of the valve assembly, such as instrument supply pressure droop, valve stuck, damaged feedback, friction, deadband analysis and trending, run continuously while the valve is in service and operating. You can also compare the present valve/actuator signature (bench set, seat load, friction, etc.) against previously stored signatures to discover performance changes, before they impact process control.

- **Faster Commissioning**—The two-way communication capability allows you to quickly commission loops by remotely identifying each instrument, verifying its calibration, reviewing stored maintenance notes, and more.

- **Upgrades Made Easy**—Using FIELDVUE HotLink™ technology, firmware upgrades can be downloaded to the DVC6000f instrument over the fieldbus segment wiring, with minimal interruption to process operations. This unique capability lets you take advantage of firmware improvements and increase functionality, while making the upgrade process fast and convenient right from the control room.

- **Easy Maintenance**—DVC6000f Series digital valve controllers are modular in design. The single module base can be removed from the instrument housing without disconnecting the field wiring, pneumatic connections or stem linkages. This module contains the critical sub-modules so component removal is quick and simple.

Control Capabilities

DVC6000f Series digital valve controllers are available with several selections of control and diagnostic capability.



Note that the Fieldbus Foundation logo indicates that the function block is certified as interoperable by the Fieldbus Foundation.

Standard Control (throttling)

DVC6000f Series digital valve controllers with Standard Control include the analog output (AO), the proportional-plus-integral-plus-derivative (PID), the Input Selector (ISEL), the output splitter (OS), the analog input (AI), the multiple analog input (MAI), the discrete output (DO), and four discrete input (DI) function blocks.

Fieldbus Control (throttling)

DVC6000f Series digital valve controllers with Fieldbus Control have the analog output (AO) function block.

Fieldbus Logic (on/off)

DVC6000f Series digital valve controllers with Fieldbus Logic include a discrete output (DO) and four discrete input (DI) function blocks, in addition to the resource and transducer block. These function blocks provide discrete (on-off) control using fieldbus communication.

Function Blocks



The AO function block provides analog output capability as defined by the Fieldbus Foundation. The AO function block provides a connection to the positioning algorithm (transducer block).



The PID function block provides proportion-plus-integral-plus-derivative control for the inputs to the function block and drives the outputs.



The ISEL function block selects from up to four inputs and may provide the selected signal as input to the PID function block. The input selection can be configured to select the first good input signal; a maximum, minimum or average value; or a hot spare.



The OS function block accepts the output from another function block (such as a PID block) and creates two outputs that are scaled or split, according to the user configuration. This block is typically used for split ranging of two control valves.



The AI function block monitors device measurements from a DVC6000f and provides it as an output to another block.



The MAI function block has the ability to process up to eight device measurements from a DVC6000f and make them available to other function blocks.



The DO function block processes a discrete set point and sends it to a specified output channel. In the digital valve controller, the discrete output block provides both normal open/closed control and the ability to position the valve in 5% increments for course throttling applications.



The DI function block processes a single discrete input from a field device and makes it available to other function blocks. In the digital valve controller, the discrete input function block can provide limit switch functionality and valve position proximity detection.

The DO and DI function blocks in a DVC6000f Series instrument can also provide dribble control using 5% positioning. In a batch environment, vessels are filled through on-off valves for speed, but there can be a problem at shutoff. The amount of material may not be “close enough” for the recipe and additional material may have to be added. This addition can be tricky and/or time consuming for the operator. The capability of being able to “crack” the valve to 5 to 10% and “dribble” in the correct amount either manually or automatically through recipe control can provide significant reduction in variability, and reduction in “FDA-like” reporting and certification. In addition, it can eliminate the need for a second smaller on-off valve or the operator climbing up and dumping in a pail of material to add “just the right amount.”

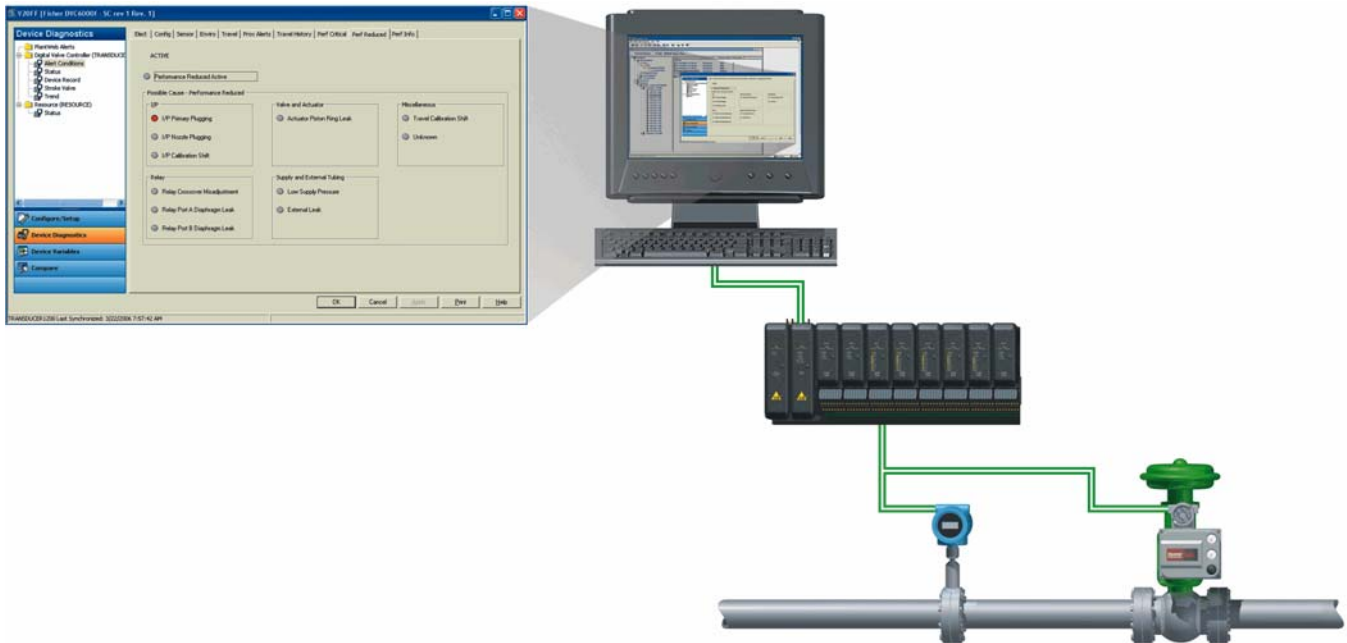

W9210-1

Figure 3. PlantWeb® Alerts, Displayed on a DeltaV™ Host System

Table 2. DVC6000f Diagnostic Tier Capabilities

CAPABILITY	DIAGNOSTIC TIER LEVEL		
	FD	AD	PD
Auto Calibration	X	X	X
Custom Characterization	X	X	X
Alerts	X	X	X
Step Response, Drive Signal Test & Dynamic Error Band, Valve Signature		X	X
Travel Control—Pressure Fallback		X	X
Performance Diagnostics			X

Additional Performance Diagnostic testing that can be scheduled or run manually during on-line operation include:

- On-Line Friction and Deadband Analysis (see figure 4)
- Friction and Deadband Trending

While all diagnostics can be run while the valve is inline, Performance Diagnostics can be performed while the valve is in service and operating.

Diagnostic Capabilities (see table 2)

Performance Diagnostics

The latest generation of Fisher FIELDVUE diagnostics, Performance Diagnostics (PD), are now built right into the DVC6000f. These diagnostics allow the DVC6000f to continuously perform checks on the valve assembly without disturbing or interrupting the control valve while it is in the process. Actuator/tubing leakage, air supply availability, calibration shift, and other issues are continuously reviewed and evaluated. The DVC6000f can then automatically trigger PlantWeb alerts, as shown in figure 3, that forewarn the user of issues before they impact process operation.

Advanced Diagnostics

Advanced Diagnostics include the following dynamic scan tests:

- Valve Signature (see figure 5)
- Dynamic Error Band
- Instrument Drive Signal

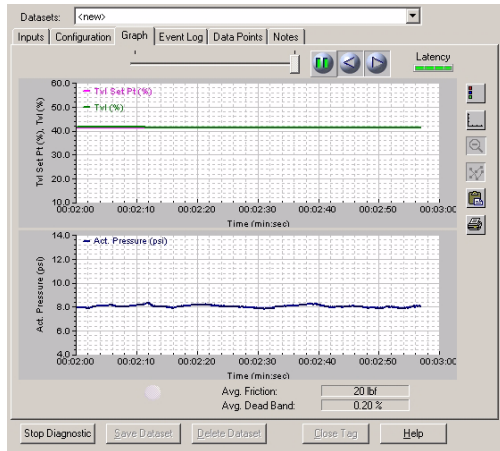

Figure 4. Valve Friction and Deadband Analysis

These diagnostics are run while the control valve is blocked out and not controlling the process. The diagnostic scans vary the positioner set point at a controlled rate and plot valve operation to determine valve dynamic performance. The valve signature test allows you to determine the valve/actuator friction, bench set, spring rate, and seat load. The Dynamic Error Band test is a combination of hysteresis and deadband plus “slewing.” Hysteresis and deadband are static measurements. However, because the valve is moving, a dynamic error, or “slewing” error is introduced.

Dynamic scan tests give a better indication of how the valve will operate under process conditions which are dynamic, not static.

The Step Response Test checks the valve assembly’s response to a changing input signal and plots travel versus time. The end results of this test allow you to evaluate the dynamic performance of the valve. The Performance Step Test provides a standardized step test with which to evaluate your valve performance. It utilizes small, medium and large changes.

Advanced Diagnostics are performed with AMS ValveLink Software. The valve must be out of service for Advanced Diagnostics to be performed.

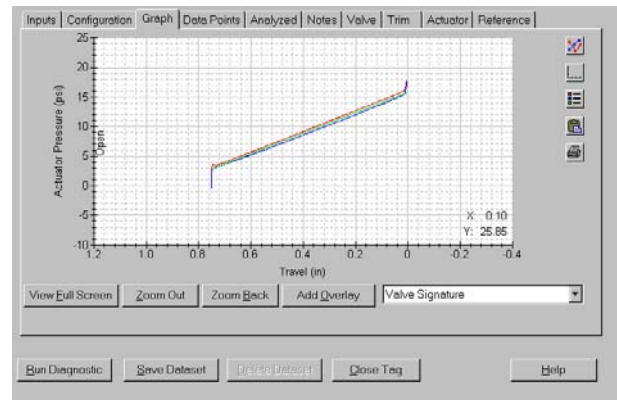

W7488/IL

Figure 5. Valve Signature Display

Fieldbus Diagnostics

Fieldbus Diagnostics capabilities include the following diagnostics:

- Key Valve Parameters

The key valve parameters allow you to monitor the total valve stem travel (travel accumulation) and the number of stem travel reversals (cycles).

- Instrument Health Parameters

The instrument health parameters alert you if there are any problems with the instrument memory, processor, or sensors. Should a problem occur, you can define how the instrument will react to the problem. You can also select which problems will cause the instrument to shutdown. These indicators may be reported as alerts. Monitoring these alerts can give you an instant indication of any problems with the instrument or the valve assembly.

PlantWeb® Alerts

The DVC6000f provides two levels of alerts; Instrument alerts and PlantWeb alerts.

Instrument alerts, when enabled, detect many operational and performance issues that may be of interest. To view these alerts, the user must open the appropriate status screen for a specific device host such as DeltaV, AMS ValveLink Software or a 375 Field Communicator.

Some instrument alerts can also be used to trigger PlantWeb alerts that will be reported in Failed, Maintenance or Advisory categories, as configured by the user (refer to figure 3). PlantWeb alerts, when enabled, are visible through the DeltaV alarm interface tools, such as the alarm banner and the alarm summary object.

When a PlantWeb alert occurs, the DVC6000f sends an event notification and waits a specified period of time for an acknowledgment to be received. This occurs even if the condition that caused the alert no longer exists. If the acknowledgment is not received within the pre-specified time-out period, the event notification is retransmitted. This reduces the possibility of alert messages getting lost.

AMS™ ValveLink® Software

AMS ValveLink Software is a Windows®-based software package that allows easy access to the information available from DVC6000f Series digital valve controllers.

Using AMS ValveLink Software, you can monitor the performance characteristics of the valve and obtain vital information without having to pull the valve from the line. Performance Diagnostic tests, including On-Line Friction, Deadband Analysis and Trending can be run while the valve is in service and operating. Valve Signature, Dynamic Error Band, and Step Response are displayed in an intuitive user-friendly environment that allows easy interpretation of data.

Diagnostic graphs can be superimposed over those previously stored to view areas of valve degradation. This allows plant personnel to concentrate efforts on equipment that needs repair, avoiding unnecessary maintenance. This diagnostic capability is readily accessible and available to you either in the control room or on the plant floor. In addition to the diagnostic features, AMS ValveLink Software contains an Audit Trail, Batch Runner for automating repetitive tasks, and Trending to view valve performance.

AMS ValveLink Software provides integration into AMS and DeltaV, with HART® and Fieldbus communications.

Model 375 Field Communicator

You can perform configuration and calibration at the valve or anywhere on the two-wire loop via a Model 375 Field Communicator (figure 6). Powerful tools such as the Setup Wizard and Auto Travel Calibration automate the tasks of commissioning DVC6000f Series digital valve controllers. These automation tools not only save time, but also provide accurate and repeatable results.



W9128

Figure 6. Model 375 Field Communicator

Installation

The Type DVC6010f digital valve controller is designed for yoke mounting to sliding stem actuators. Type DVC6020f digital valve controllers are designed for mounting to rotary actuators or long stroke sliding stem actuators (over 4-inches travel). Type DVC6030f digital valve controllers are designed for mounting on virtually any quarter-turn actuator. Dimensions for valve-mounted instruments are shown in figures 7, 8, and 9. Dimensions for remote-mounted instruments are shown in figures 10 and 11.

The Type DVC6005f digital valve controller base unit may be remote mounted on a 2-inch pipestand or a wall. The remote-mounted Type DVC6005f base unit connects to the Type DVC6015, DVC6025, or DVC6035 feedback unit mounted on the actuator. Feedback wiring and pneumatic tubing to the control valve assembly must be connected in the field.

The digital valve controllers are loop powered and do not require additional power. Electrical connections are made in the terminal box.

All pressure connections on the digital valve controllers are 1/4 NPT internal connections. Remote venting is available and tubing with a minimum outside diameter of 3/8-inch (9.5 mm) is recommended for connecting the digital valve controller output to the actuator input.

Product Bulletin

62.1:DVC6000f
March 2007

DVC6000f Digital Valve Controllers

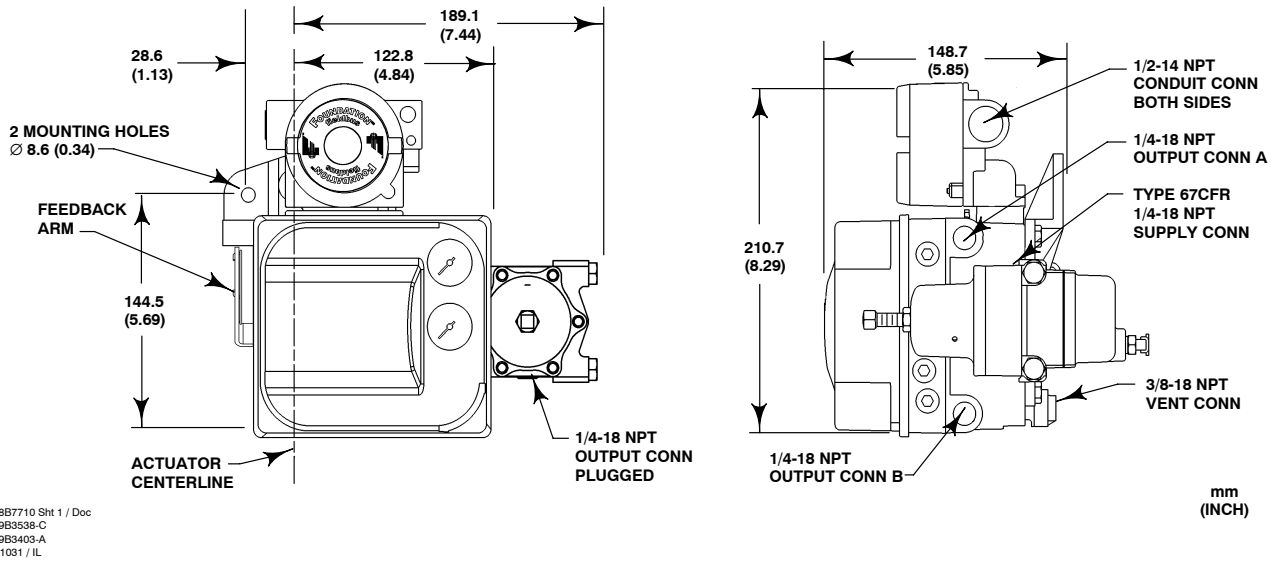

Figure 7. Dimensions for Type DVC6010f Digital Valve Controller with Integrally Mounted Filter Regulator

Ordering Information

When ordering, specify:

1. Type number
2. Actuator type and size
3. Maximum actuator travel or rotation
4. Options
 - a. Supply pressure regulator
 - b. Supply and output gauges
 - c. Function Block Suite
 - Standard Control
 - Fieldbus Control

- Fieldbus Logic
- d. Diagnostic Level
 - Performance Diagnostics
 - Advanced Diagnostics
 - Fieldbus Diagnostics

Note

Neither Emerson, Emerson Process Management, nor any of their affiliated entities assumes responsibility for the selection, use, and maintenance of any product. Responsibility for the selection, use, and maintenance of any product remains with the purchaser and end-user.

DVC6000f Digital Valve Controllers

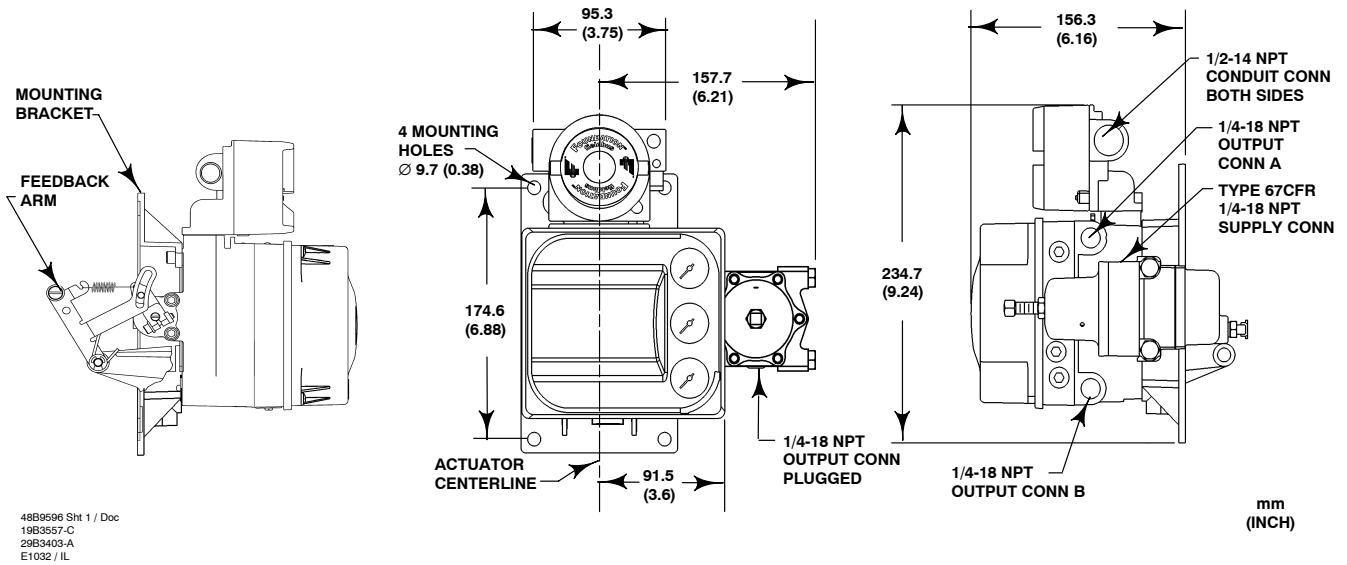

Figure 8. Dimensions for Type DVC6020f Digital Valve Controller with Integrally Mounted Filter Regulator

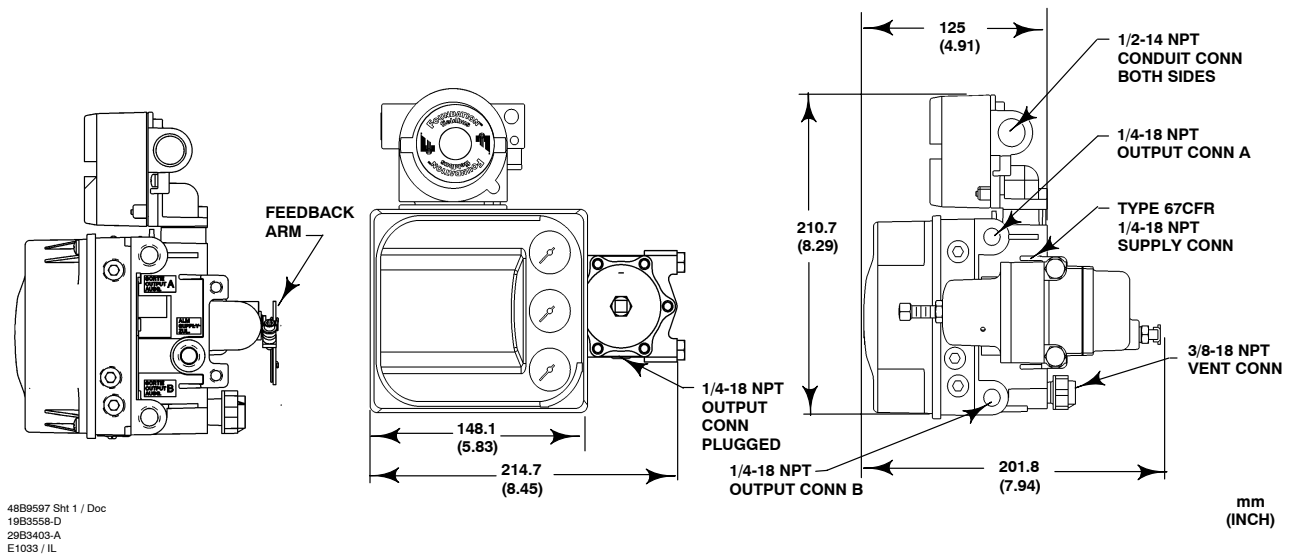
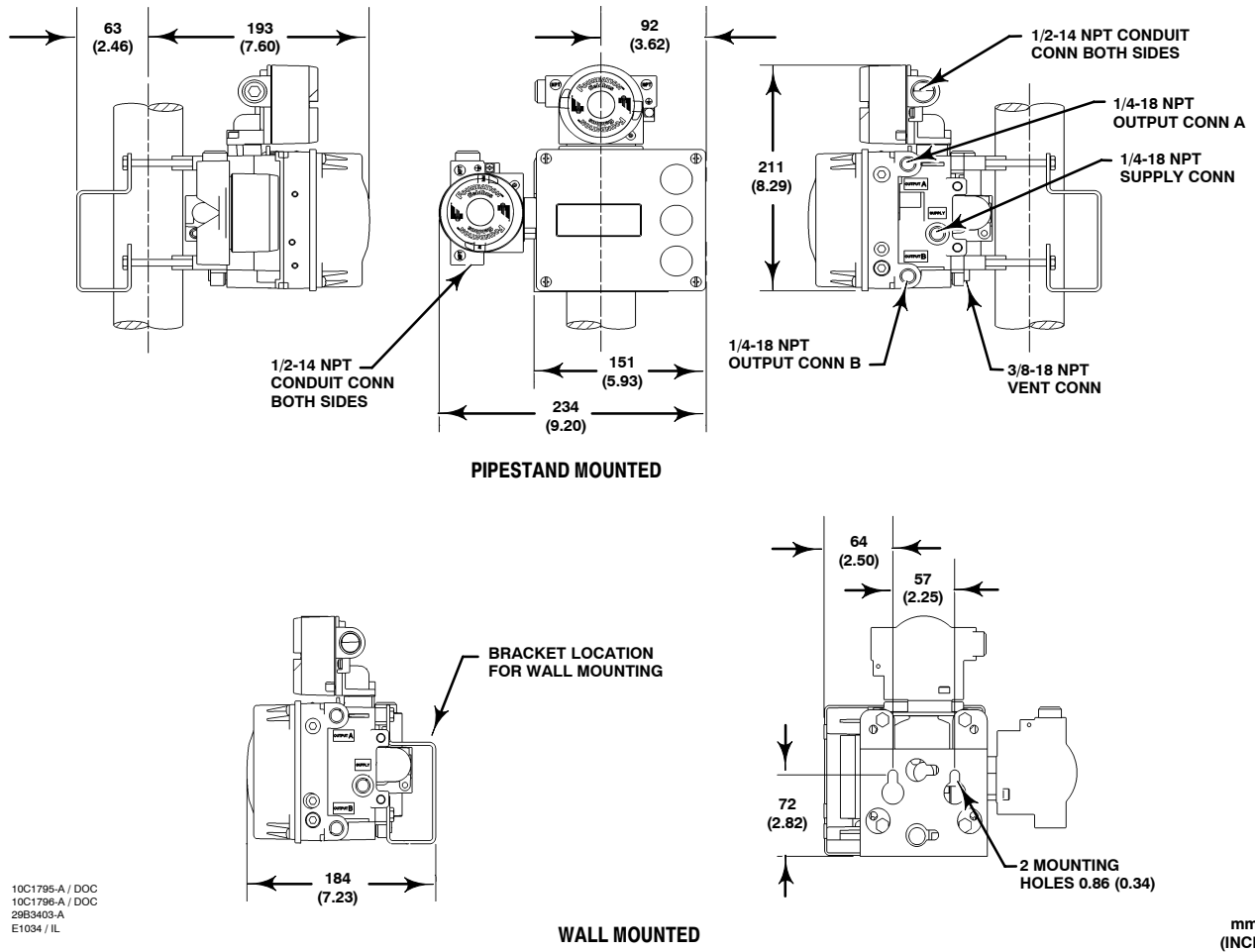

Figure 9. Dimensions for Type DVC6030f Digital Valve Controller with Integrally Mounted Filter Regulator

Product Bulletin

62.1:DVC6000f
 March 2007

DVC6000f Digital Valve Controllers



10C1795-A / DOC
 10C1796-A / DOC
 29B3403-A
 E1034 / IL

mm
(INCH)

Figure 10. Dimensions for Remote-Mounted Instruments—Type DVC6005f Base Unit

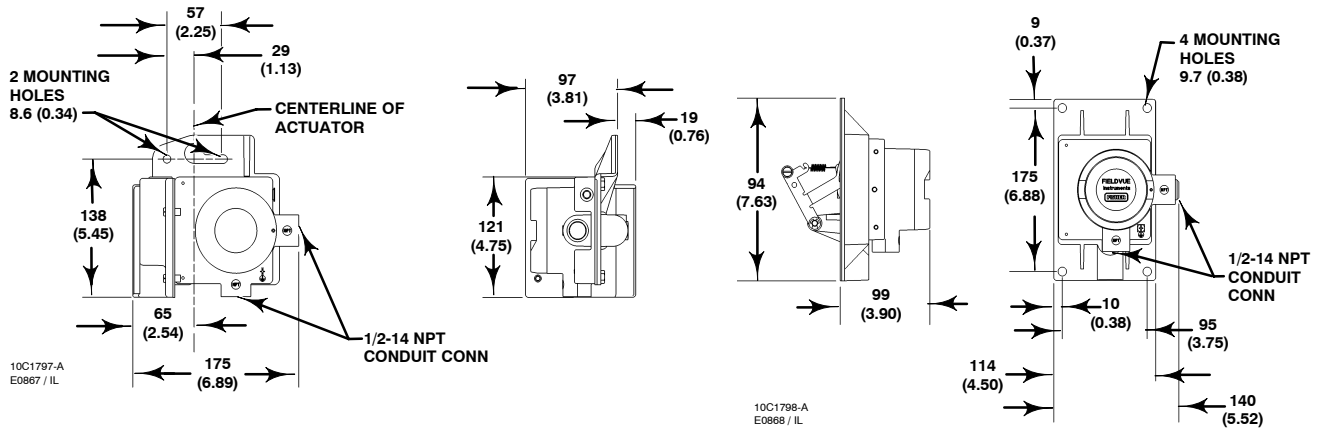

**TYPE DVC6015 SLIDING STEM ACTUATOR MOUNTING
UP TO 102 mm (4-INCH) TRAVEL**

**TYPE DVC6025 ROTARY AND LONG-STROKE SLIDING STEM
ACTUATOR MOUNTING**

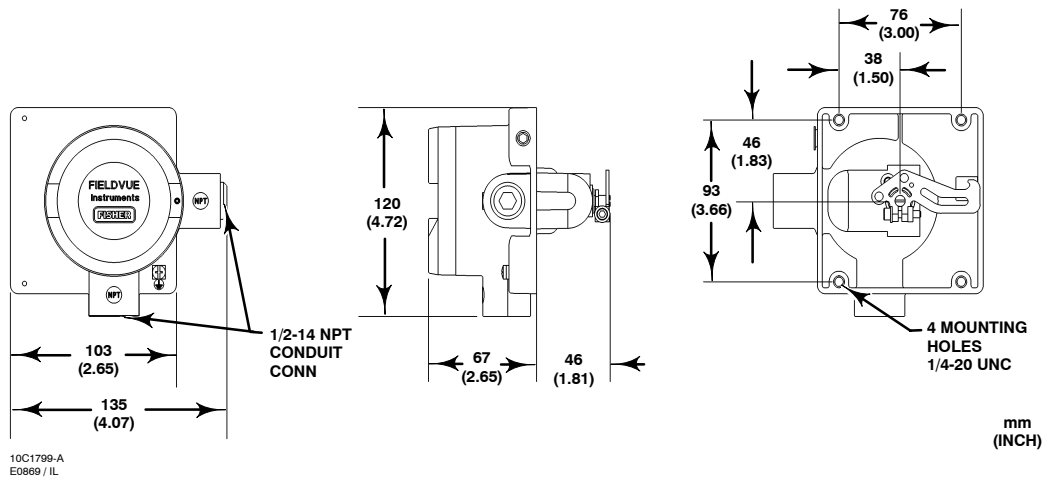

TYPE DVC6035 ROTARY ACTUATOR SHAFT MOUNTING

Figure 11. Dimensions for Remote-Mounted Instruments—Feedback Units

Product Bulletin

62.1:DVC6000f
March 2007

DVC6000f Digital Valve Controllers

Table 3. DVC6000f Series Hazardous Area Classifications for Canada—CSA

CERTIFICATION BODY	TYPE	CERTIFICATION OBTAINED	ENTITY RATING		TEMPERATURE CODE	ENCLOSURE RATING
CSA	DVC60x0F DVC60x0FS (x = 1,2,3)	(Intrinsic Safety) Class/Division Class I,II,III Division 1 GP A,B,C, D,E,F,G per drawing GE04331 (including FISCO)	FIELDBUS		T5(T _{amb} ≤ 80°C)	4X
		V _{max} = 30 Vdc I _{max} = 226 mA C _i = 5 nF L _i = 0 mH				
			FISCO		T5(T _{amb} ≤ 80°C)	4X
		V _{max} = 17.5 Vdc I _{max} = 380 mA C _i = 5 nF L _i = 0 mH P _i = 5.32 W				
		(Explosion Proof) Class/Division Class I, Division 1 GP B,C,D	---		T6(T _{amb} ≤ 80°C)	4X
		Class I Division 2 GP A,B,C,D Class II Division 1 GP E,F,G Class III Division 1	---			
	DVC6005F	(Intrinsic Safety) Class/Division Class I,II,III Division 1 GP A,B,C, D,E,F,G per drawing GE07476 (including FISCO)	FIELDBUS		T6(T _{amb} ≤ 60°C)	4X
			V _{max} = 30 Vdc I _{max} = 226 mA C _i = 5 nF L _i = 0 mH	V _{oc} = 8.6 Vdc I _{sc} = 2.3 mA C _a = 6.2 μF L _a = 100 mH		
			FISCO			
			V _{max} = 17.5 Vdc I _{max} = 380 mA C _i = 5 nF L _i = 0 mH	V _{oc} = 8.6 Vdc I _{sc} = 2.3 mA C _a = 6.2 μF L _a = 100 mH		
		(Explosion Proof) Class/Division Class I, Division 1 GP C,D	---		T6(T _{amb} ≤ 60°C)	
		Class I Division 2 GP A,B,C,D Class II Division 1 GP E,F,G Class III Division 1	---		T6(T _{amb} ≤ 60°C)	
DVC60x5 (x = 1,2,3)	(Intrinsic Safety) Class/Division Class I,II,III Division 1 GP A,B,C, D,E,F,G per drawing GE07476	V _{max} = 10Vdc I _{max} = 4 mA C _i = 0 nF L _i = 0 mH		T4(T _{amb} ≤ 125°C) T5(T _{amb} ≤ 95°C) T6(T _{amb} ≤ 80°C)	4X	
		---		T4(T _{amb} ≤ 125°C) T5(T _{amb} ≤ 95°C) T6(T _{amb} ≤ 80°C)	4X	
	(Explosion Proof) Class/Division Class I, Division 1 GP B,C,D	---		T4(T _{amb} ≤ 125°C) T5(T _{amb} ≤ 95°C) T6(T _{amb} ≤ 80°C)	4X	
	Class I Division 2 GP A,B,C,D Class II Division 1 GP E,F,G Class III Division 1	---		T4(T _{amb} ≤ 125°C) T5(T _{amb} ≤ 95°C) T6(T _{amb} ≤ 80°C)	4X	

DVC6000f Digital Valve Controllers

Table 4. DVC6000f Series Hazardous Area Classifications for United States—FM

CERTIFICATION BODY	TYPE	CERTIFICATION OBTAINED	ENTITY RATING	TEMPERATURE CODE	ENCLOSURE RATING	
FM	DVC60x0F DVC60x0FS (x = 1,2,3)	(Intrinsic Safety) Class/Division Class I,II,III Division 1 GP A,B,C, D,E,F,G per drawing GE04332 (including FISCO)	FIELDBUS	T5(T _{amb} ≤ 80°C)	4X	
			V _{max} = 30 Vdc I _{max} = 226 mA C _i = 5 nF L _i = 0 mH P _i = 1.4 W			
			FISCO			
		V _{max} = 17.5 Vdc I _{max} = 380 mA C _i = 5 nF L _i = 0 mH P _i = 5.32 W				
		(Explosion Proof) Class/Division Class I, Division 1 GP B,C,D	---	T6(T _{amb} ≤ 80°C)	4X	
		Class I Division 2 GP A,B,C,D Class II,III Division 1 GP E,F,G Class II,III Division 2 GP F,G	---	T6(T _{amb} ≤ 80°C)	4X	
	DVC6005F	(Intrinsic Safety) Class/Division Class I,II,III Division 1 GP A,B,C, D,E,F,G per drawing GE07475 (including FISCO)	FIELDBUS	T6(T _{amb} ≤ 60°C)	4X	
			V _{max} = 24 Vdc I _{max} = 226 mA C _i = 5 nF L _i = 0 mH P _i = 1.4 W			V _{oc} = 8.6 Vdc I _{sc} = 2.3 mA C _a = 6.2 μF L _a = 100 mH P _o = 5 mH
			FISCO			
		V _{max} = 17.5 Vdc I _{max} = 380 mA C _i = 5 nF L _i = 0 mH P _i = 5.32 W	V _{oc} = 8.6 Vdc I _{sc} = 2.3 mA C _a = 6.2 μF L _a = 100 mH P _o = 5 mW			
		(Explosion Proof) Class/Division Class I, Division 1 GP C,D	---	T6(T _{amb} ≤ 60°C)	4X	
		Class I Division 2 GP A,B,C,D Class II,III Division 1 GP E,F,G Class II,III Division 2 GP F,G	---	T6(T _{amb} ≤ 60°C)	4X	
DVC60x5 (x = 1,2,3)	(Intrinsic Safety) Class/Division Class I,II,III Division 1 GP A,B,C, D,E,F,G per drawing GE07475	V _{max} = 10 Vdc I _{max} = 4 mA C _i = 0 nF L _i = 0 mH P _i = 10 mW	T4(T _{amb} ≤ 125°C) T5(T _{amb} ≤ 95°C) T6(T _{amb} ≤ 80°C)	4X		
	(Explosion Proof) Class/Division Class I, Division 1 GP A,B,C,D	---	T4(T _{amb} ≤ 125°C) T5(T _{amb} ≤ 95°C) T6(T _{amb} ≤ 80°C)	4X		
	Class I Division 2 GP A,B,C,D Class II,III Division 1 GP E,F,G Class II,III Division 2 GP F,G	---	T4(T _{amb} ≤ 125°C) T5(T _{amb} ≤ 95°C) T6(T _{amb} ≤ 80°C)	4X		

Product Bulletin

62.1:DVC6000f
March 2007

DVC6000f Digital Valve Controllers

Table 5. DVC6000f Series Hazardous Area Classifications—ATEX

CERTIFICATE	TYPE	CERTIFICATION OBTAINED	ENTITY RATING	TEMPERATURE CODE	ENCLOSURE RATING	
ATEX	DVC60x0F DVC60x0FS (x = 1,2,3)	Ⓢ II 1 G D Gas EEx ia IIC T5/T6—Intrinsic Safety Dust T85°C (T _{amb} ≤ 80°C)	FIELDBUS U _i = 24 Vdc I _i = 226 mA C _i = 5 nF L _i = 0 mH P _i = 1.4 W	T5(T _{amb} ≤ 80°C) T6(T _{amb} ≤ 75°C)	IP66	
			FISCO U _i = 17.5 Vdc I _i = 380 mA C _i = 5 nF L _i = 0 mH P _i = 5.32 W			

			Ⓢ II 2 G D Gas EEx d IIB+H2 T5/T6—Flameproof Dust T90°C (T _{amb} ≤ 85°C)	---	T5(T _{amb} ≤ 80°C) T6(T _{amb} ≤ 75°C)	IP66
			Ⓢ II 3 G D Gas EEx nCL IIC T5/T6—Type n Dust T85°C (T _{amb} ≤ 80°C)	---	T5(T _{amb} ≤ 80°C) T6(T _{amb} ≤ 75°C)	IP66
		DVC6005F	Ⓢ II 1 G D Gas EEx ia IIC T5/T6—Intrinsic Safety Dust T85°C (T _{amb} ≤ 80°C)	FIELDBUS U _i = 24 Vdc I _i = 226 mA C _i = 5 nF L _i = 0 mH P _i = 1.4 W	T5(T _{amb} ≤ 80°C) T6(T _{amb} ≤ 75°C)	IP66
	U _o = 8.6 Vdc I _o = 2.3 mA C _a = 6.2 μF L _a = 100 mH P _o = 5 mW					
	FISCO U _i = 17.5 Vdc I _i = 380 mA C _i = 5 nF L _i = 0 mH P _i = 5.32 W					
			Ⓢ II 2 G D Gas EEx d IIB T5/T6—Flameproof Dust T90°C (T _{amb} ≤ 80°C)	---	T5(T _{amb} ≤ 80°C) T6(T _{amb} ≤ 75°C)	IP66
			Ⓢ II 3 G D Gas EEx nL IIC T5/T6—Type n Dust T85°C (T _{amb} ≤ 80°C)	---	T5(T _{amb} ≤ 80°C) T6(T _{amb} ≤ 75°C)	IP66
		DVC60x5 (x = 1,2,3)	Ⓢ II 1 G D Gas EEx ia IIC T4/T5/T6—Intrinsic Safety Dust T130°C (T _{amb} ≤ 125°C)	U _i = 10 Vdc I _i = 4 mA C _i = 0 nF L _i = 0 mH P _i = 5 mW	T4(T _{amb} ≤ 125°C) T5(T _{amb} ≤ 95°C) T6(T _{amb} ≤ 80°C)	IP66

		Ⓢ II 2 G D Gas EEx d IIC T4/T5/T6—Flameproof Dust T130°C (T _{amb} ≤ 125°C)	---	T4(T _{amb} ≤ 125°C) T5(T _{amb} ≤ 95°C) T6(T _{amb} ≤ 80°C)	IP66	
		Ⓢ II 3 G D Gas EEx nA IIC T4/T5/T6—Type n Dust T130°C (T _{amb} ≤ 125°C)	---	T4(T _{amb} ≤ 125°C) T5(T _{amb} ≤ 95°C) T6(T _{amb} ≤ 80°C)	IP66	

DVC6000f Digital Valve Controllers

Table 6. DVC6000f Series Hazardous Area Classifications—IECEX

CERTIFICATE	TYPE	CERTIFICATION OBTAINED	ENTITY RATING	TEMPERATURE CODE	ENCLOSURE RATING		
IECEX	DVC60x0F DVC60x0FS (x = 1,2,3)	Gas Ex ia IIC T5/T6—Intrinsic Safety	FIELDBUS		T5(T _{amb} ≤ 80°C) T6(T _{amb} ≤ 75°C)	IP66	
			V _{max} = 24 Vdc I _{max} = 226 mA C _i = 5 nF L _i = 0 mH P _i = 1.4 W				
			FISCO				
		V _{max} = 17.5 Vdc I _{max} = 380 mA C _i = 5 nF L _i = 0 mH P _i = 5.32 W					
		Gas Ex d IIB+H2 T5/T6—Flameproof	---	T5(T _{amb} ≤ 80°C) T6(T _{amb} ≤ 75°C)	IP66		
		Gas Ex nC IIC T5/T6—Type n	---	T5(T _{amb} ≤ 80°C) T6(T _{amb} ≤ 75°C)	IP66		
	DVC6005F	Gas Ex ia IIC T5/T6—Intrinsic Safety	FIELDBUS		T5(T _{amb} ≤ 80°C) T6(T _{amb} ≤ 75°C)	IP66	
			V _{max} = 24 Vdc I _{max} = 226 mA C _i = 5 nF L _i = 0 mH P _i = 1.4 W	V _{oc} = 8.6 Vdc I _{sc} = 2.3 mA C _a = 6.2 μF L _a = 100 mH P _o = 5 mH			
			FISCO				
		V _{max} = 17.5 Vdc I _{max} = 380 mA C _i = 5 nF L _i = 0 mH P _i = 5.32 W	V _{oc} = 8.6 Vdc I _{sc} = 2.3 mA C _a = 6.2 μF L _a = 100 mH P _o = 5 mH				
		Gas Ex d IIB T5/T6—Flameproof	---	T5(T _{amb} ≤ 80°C) T6(T _{amb} ≤ 75°C)	IP66		
		Gas Ex nC IIC T5/T6—Type n	---	T5(T _{amb} ≤ 80°C) T6(T _{amb} ≤ 75°C)	IP66		
DVC60x5 (x = 1,2,3)	Gas Ex ia IIC T4/T5/T6—Intrinsic Safety	V _{max} = 10 Vdc I _{max} = 4 mA C _i = 0 nF L _i = 0 mH P _i = 10 mW	T4(T _{amb} ≤ 125°C) T5(T _{amb} ≤ 95°C) T6(T _{amb} ≤ 80°C)	IP66			
	Gas Ex d IIC T4/T5/T6—Flameproof	---	T4(T _{amb} ≤ 125°C) T5(T _{amb} ≤ 95°C) T6(T _{amb} ≤ 80°C)	IP66			
	Gas Ex nA IIC T4/T5/T6—Type n	---	T4(T _{amb} ≤ 125°C) T5(T _{amb} ≤ 95°C) T6(T _{amb} ≤ 80°C)	IP66			

FIELDVUE, HotLink, ValveLink, and Fisher are marks owned by Fisher Controls International LLC, a member of the Emerson Process Management business division of Emerson Electric Co. AMS and DeltaV are marks owned by one of the companies in the Emerson Process Management business division of Emerson Electric Co. Emerson Process Management, Emerson, and the Emerson logo are trademarks and service marks of Emerson Electric Co. FOUNDATION and the Fieldbus Foundation logo are marks owned by Fieldbus Foundation. HART is a mark owned by HART Communication Foundation. All other marks are the property of their respective owners.

The contents of this publication are presented for informational purposes only, and while every effort has been made to ensure their accuracy, they are not to be construed as warranties or guarantees, express or implied, regarding the products or services described herein or their use or applicability. We reserve the right to modify or improve the designs or specifications of such products at any time without notice.

Neither Emerson, Emerson Process Management, nor any of their affiliated entities assumes responsibility for the selection, use and maintenance of any product. Responsibility for the selection, use and maintenance of any product remains with the purchaser and end-user.

Emerson Process Management

Marshalltown, Iowa 50158 USA
Cernay 68700 France
Sao Paulo 05424 Brazil
Singapore 128461

www.Fisher.com

