

# Rosemount 3144P Temperature Transmitter

- *Sensor Drift Alert and Hot Backup<sup>®</sup> features improve measurement reliability while the Transmitter-Sensor Matching feature improves temperature measurement accuracy.*
- *Communicates using either 4-20 mA/HART<sup>®</sup> or FOUNDATION<sup>™</sup> fieldbus protocol*
- *The integral LCD Display (optional) conveniently displays sensor values and transmitter diagnostics information.*
- *Capable of single-sensor and dual-sensor inputs. Differential and average temperature measurement increases system flexibility.*
- *Dual-compartment housing provides the highest reliability in harsh industrial environments.*
- *Safety certified to IEC 61508 by TÜViT*



## Content

The Ultimate Temperature Transmitter for Critical Control and Safety Applications . . . . .	page 2
Specifications	
<i>HART and FOUNDATION</i> Fieldbus Specifications . . . . .	page 3
<i>HART</i> / 4-20 mA Specifications . . . . .	page 6
<i>FOUNDATION</i> Fieldbus Specifications . . . . .	page 7
Product Certifications . . . . .	page 8
Dimensional Drawings. . . . .	page 12
Ordering Information . . . . .	page 15
Configuration Data Sheet	
<i>HART</i> / 4-20 mA Transmitter . . . . .	page 20
<i>FOUNDATION</i> Fieldbus Transmitter . . . . .	page 22

## The Ultimate Temperature Transmitter for Critical Control and Safety Applications

The Rosemount 3144P Temperature Transmitter provides superior accuracy, stability, and reliability – making it the industry-leading temperature transmitter used in critical control and safety applications. The 3144P can be ordered with either 4–20 mA/HART or a completely digital *FOUNDATION* fieldbus protocol. It has the capability to accept either single-sensor or dual-sensor inputs. This dual-sensor input capability allows the transmitter to accept simultaneous input from two independent sensors, enabling measurement of differential temperatures, averaging temperature, or redundant temperature measurement. The transmitter can be configured for a variety of sensor inputs: RTD, thermocouple, millivolt, or ohm. The 3144P (*HART*) is approved for use in Safety Instrumented Systems (third party validated metrics are available for the 3144P. Testing done per IEC 61508 for Safety Instrumented Systems).

### Best in Class Accuracy and Reliability

The transmitter provides industry-leading five-year stability, which reduces maintenance costs. The Transmitter-Sensor Matching feature eliminates interchangeability error, which improves accuracy by 75%. Sensor Drift Alert enables continuous monitoring of the differential temperature for two sensors. When one sensor drifts, the differential of the sensors will increase. If this difference exceeds defined limits, the user is alerted of an unreliable measurement. The *Hot Backup* feature can reduce the risk of losing important temperature measurements by 80% when the measurement automatically switches to the backup sensor if the primary sensor fails.

### FOUNDATION Fieldbus and HART Protocols

High performance and advanced diagnostics are available with *HART* or *FOUNDATION* fieldbus communication. These transmitters offer diagnostics that provide continuous measurement status (good, bad, or uncertain), as well as sensor failure indication. Both transmitters provide performance information to AMS.

### Integral LCD Display

Local indication of temperature measurement and diagnostics provides immediate and accurate verification of process conditions.

### Measurement Flexibility

The 3144P is capable of single-sensor or dual-sensor input. This also allows for configuration of differential or average temperature measurements.

### Designed for Harsh Environments

The 3144P is designed with a dual-compartment housing that provides the highest reliability in harsh environments. The dual-compartment housing provides isolation between the electronics and terminal compartments. The large terminal block allows for easier wire installation. Enhanced EMI rejection and filtering resulting in unmatched stability in process measurement.

### Certified for use in SIS Applications

The 3144P is certified by TÜVIT to IEC61508 for non-redundant in SIL 1 and 2 Safety Instrumented Systems and redundant use in SIL 3 Safety Instrumented Systems. In allowable installations, the 3144P HART electronics can be upgraded to safety certified electronics.

### Advanced Temperature Diagnostics

The advanced 3144P powers *PlantWeb*<sup>®</sup> by communicating important temperature diagnostics and *PlantWeb* alerts to ensure process health and enable multi-sensor architecture.



## Rosemount Temperature Solutions

### Rosemount 644 Temperature Transmitter

Head or rail mount styles available with *HART* or *FOUNDATION* fieldbus protocol.

### Rosemount 848T Eight Input Temperature Transmitter

Eight input transmitter available with *FOUNDATION* fieldbus protocol.

### Rosemount 3420 Fieldbus Interface Module

Provides an interface between *FOUNDATION* fieldbus instruments and systems without fieldbus capability using standard interface protocols.

### Rosemount 248 Temperature Transmitter

Head mount style (DIN B) available with *HART* protocol and complete temperature assembly.

### Rosemount 244ER Temperature Transmitter

Rail-mount style that is PC-programmable.

### Rosemount sensors, thermowells, and extensions

Rosemount has a broad offering of RTD and thermocouples that are designed to meet plant requirements.

# Specifications

## HART AND FOUNDATION FIELDBUS

### Functional

#### Inputs

User-selectable. See "Accuracy" on page 4 for sensor options.

#### Output

2-wire device with either 4–20 mA/HART, linear with temperature or input, or completely digital output with FOUNDATION fieldbus communication (ITK 4.5 compliant).

#### Isolation

Input/output isolation tested up to 500 V rms (707 V dc).

#### Humidity Limits

0–100% relative humidity.

#### Update Time

Approximately 0.5 seconds for a single sensor (1 second for dual sensors).

### Physical

#### Conduit Connections

The standard field mount housing has ½–14 NPT conduit entries. Additional conduit entry type are available, including PG13.5 (PG11), M20 X 1.5 (CM20), or JIS G ½. When any of these additional entry types are ordered, adapters are placed in the standard field housing so these alternative conduit types fit correctly. See "Dimensional Drawings" on page 12 for dimensions.

#### Materials of Construction

Electronics Housing

- Low-copper aluminum or CF-8M (cast version of 316 Stainless Steel)

Paint

- Polyurethane

#### Cover O-rings

Buna-N

#### Mounting

Transmitters may be attached directly to the sensor. Optional mounting brackets (codes B4 and B5) permit remote mounting. See "Optional Transmitter Mounting Brackets" on page 13.

#### Weight

Aluminum <sup>(1)</sup>	Stainless Steel <sup>(1)</sup>
3.1 lb (1.4 kg)	7.8 lb (3.5 kg)

(1) Add 0.5 lb (0.2 kg) for meter or 1.0 lb (0.5 kg) for bracket options.

#### Enclosure Ratings

NEMA 4X, CSA Enclosure Type 4X, IP66, and IP68.

### Performance

The 3144P maintains a specification conformance of at least 3  $\sigma$ .

#### Stability

- $\pm 0.1\%$  of reading or 0.1 °C, whichever is greater, for 24 months for RTDs.
- $\pm 0.1\%$  of reading or 0.1 °C, whichever is greater, for 12 months for thermocouples.

#### 5 Year Stability

- $\pm 0.25\%$  of reading or 0.25 °C, whichever is greater, for 5 years for RTDs.
- $\pm 0.5\%$  of reading or 0.5 °C, whichever is greater, for 5 years for thermocouples.

#### Vibration Effect

Tested to the following with no effect on performance:

Frequency	Acceleration
10–60 Hz	0.21 mm peak displacement
60–2000 Hz	3 g

#### Self Calibration

The analog-to-digital measurement circuitry automatically self-calibrates for each temperature update by comparing the dynamic measurement to extremely stable and accurate internal reference elements.

#### RFI Effect

Worst case RFI effect is equivalent to the transmitter's nominal accuracy specification, according to Table on page 4, when tested in accordance with IEC 61000-4-3, 30 V/m (HART) / 10 V/m (FOUNDATION fieldbus), 80 to 1000 MHz, with unshielded cable.

#### CE Electromagnetic Compatibility Compliance Testing

The 3144P meets all requirements listed under IEC 61326: Amendment 1, 1998.

#### External Ground Screw Assembly

The external ground screw assembly can be ordered by specifying code G1 when an enclosure is specified. However, some approvals include the ground screw assembly in the transmitter shipment, hence it is not necessary to order code G1. The table below identifies which approval options include the external ground screw assembly.

Approval Type	External Ground Screw Assembly Included? <sup>(1)</sup>
NA, E5, K5, K6, KB	No—Order option code G1
N1, E1, I1, ND, K1, E7, N7, I7, K7, KA, I2 and E4	Yes

(1) Code G1 is also included with Integral Protector option code T1 and does not need to be ordered separately.

# Rosemount 3144P

## Hardware Tag

- No charge
- 2 lines of 28 characters (56 characters total)
- Tags are stainless steel
- Permanently attached to transmitter
- Character height is  $\frac{1}{16}$ -in. (1.6mm)
- A wire-on tag is available upon request. 5 lines of 12 characters (60 characters total)

## Software Tag

- HART transmitter can store up to 8 characters. FOUNDATION fieldbus transmitters can store up to 32 characters.
- Can be ordered with different software and hardware tags.
- If no software tag characters are specified, the first 8 characters of the hardware tag are the default.

## Accuracy

Sensor Options	Sensor Reference	Input Ranges		Recommended Min. Span <sup>(1)</sup>		Digital Accuracy <sup>(2)</sup>		D/A Accuracy <sup>(3)(4)</sup>	
		°C	°F	°C	°F	°C	°F		
<b>2-, 3-, 4-wire RTDs</b>									
Pt 100	IEC 751, 1995 ( $\alpha = 0.00385$ )	-200 to 850	-328 to 1562	10	18	± 0.10	± 0.18	±0.02% of span	
Pt 100	JIS 1604, 1981 ( $\alpha = 0.003916$ )	-200 to 645	-328 to 1193	10	18	± 0.10	± 0.18	±0.02% of span	
Pt 200	IEC 751, 1995 ( $\alpha = 0.00385$ )	-200 to 850	-328 to 1562	10	18	± 0.22	± 0.40	±0.02% of span	
PT 500	IEC 751, 1995 ( $\alpha = 0.00385$ )	-200 to 850	-328 to 1562	10	18	± 0.14	± 0.25	±0.02% of span	
Pt 1000	IEC 751, 1995 ( $\alpha = 0.00385$ )	-200 to 300	-328 to 572	10	18	± 0.10	± 0.18	±0.02% of span	
Ni 120	Edison Curve No. 7	-70 to 300	-94 to 572	10	18	± 0.08	± 0.14	±0.02% of span	
Cu 10	Edison Copper Winding No. 15	-50 to 250	-58 to 482	10	18	±1.00	± 1.80	±0.02% of span	
<b>Thermocouples<sup>(5)</sup></b>									
Type B <sup>(6)</sup>	NIST Monograph 175, IEC 584	100 to 1820	212 to 3308	25	45	± 0.75	± 1.35	±0.02% of span	
Type E	NIST Monograph 175, IEC 584	-50 to 1000	-58 to 1832	25	45	± 0.20	± 0.36	±0.02% of span	
Type J	NIST Monograph 175, IEC 584	-180 to 760	-292 to 1400	25	45	± 0.25	± 0.45	±0.02% of span	
Type K <sup>(7)</sup>	NIST Monograph 175, IEC 584	-180 to 1372	-292 to 2502	25	45	± 0.25	± 0.45	±0.02% of span	
Type N	NIST Monograph 175, IEC 584	-200 to 1300	-328 to 2372	25	45	± 0.40	± 0.72	±0.02% of span	
Type R	NIST Monograph 175, IEC 584	0 to 1768	32 to 3214	25	45	± 0.60	± 1.08	±0.02% of span	
Type S	NIST Monograph 175, IEC 584	0 to 1768	32 to 3214	25	45	± 0.50	± 0.90	±0.02% of span	
Type T	NIST Monograph 175, IEC 584	-200 to 400	-328 to 752	25	45	± 0.25	± 0.45	±0.02% of span	
DIN Type L	DIN 43710	-200 to 900	-328 to 1652	25	45	± 0.35	± 0.63	±0.02% of span	
DIN Type U	DIN 43710	-200 to 600	-328 to 1112	25	45	± 0.35	± 0.63	±0.02% of span	
Type W5Re/ W26Re	ASTM E 988-96	0 to 2000	32 to 3632	25	45	± 0.70	± 1.26	±0.02% of span	
<b>Millivolt Input</b>		-10 to 100 mV		3 mV		±0.015 mV		±0.02% of span	
<b>2-, 3-, 4-wire Ohm Input</b>		0 to 2000 ohms		20 ohm		±0.35 ohm		±0.02% of span	

(1) No minimum or maximum span restrictions within the input ranges. Recommended minimum span will hold noise within accuracy specification with damping at zero seconds.

(2) Digital accuracy: Digital output can be accessed by the 375 Field Communicator.

(3) Total Analog accuracy is the sum of digital and D/A accuracies.

(4) Applies to HART / 4-20 mA devices.

(5) Total digital accuracy for thermocouple measurement: sum of digital accuracy +0.25 °C (0.45 °F) (cold junction accuracy).

(6) Digital accuracy for NIST Type B is ±3.0 °C (±5.4 °F) from 100 to 300 °C (212 to 572 °F).

(7) Digital accuracy for NIST Type K is ±0.50 °C (±0.9 °F) from -180 to -90 °C (-292 to -130 °F).

## Reference Accuracy Example (HART only)

When using a Pt 100 ( $\alpha = 0.00385$ ) sensor input with a 0 to 100 °C span: Digital Accuracy would be ±0.10 °C, D/A accuracy would be ±0.02% of 100 °C or ±0.02 °C, Total = ±0.12 °C.

## Differential Capability Exists Between Any Two Sensor Types (dual-sensor option)

For all differential configurations, the input range is X to Y where:

- X = Sensor 1 minimum – Sensor 2 maximum and
- Y = Sensor 1 maximum – Sensor 2 minimum.

## Digital Accuracy for Differential Configurations (dual-sensor option, HART only)

- Sensor types are similar (e.g., both RTDs or both T/Cs): Digital Accuracy = 1.5 times worst case accuracy of either sensor type.
- Sensor types are dissimilar (e.g., one RTD, one T/C): Digital Accuracy = Sensor 1 Accuracy + Sensor 2 Accuracy.

**Ambient Temperature Effect**

TABLE 1. Ambient Temperature Effect

Sensor Options	Digital Accuracy per 1.0 °C (1.8 °F) Change in Ambient <sup>(1)</sup>	Range	D/A Effect <sup>(2)</sup>
<b>2-, 3-, or 4- Wire RTDs</b>			
Pt 100 ( $\alpha = 0.00385$ )	0.0015 °C	Entire Sensor Input Range	0.001% of span
Pt 100 ( $\alpha = 0.003916$ )	0.0015 °C	Entire Sensor Input Range	0.001% of span
Pt 200	0.0023 °C	Entire Sensor Input Range	0.001% of span
Pt 500	0.0015 °C	Entire Sensor Input Range	0.001% of span
Pt 1000	0.0015 °C	Entire Sensor Input Range	0.001% of span
Ni 120	0.0010 °C	Entire Sensor Input Range	0.001% of span
Cu 10	0.015 °C	Entire Sensor Input Range	0.001% of span
<b>Thermocouples</b>			
Type B	0.014 °C 0.029 °C – 0.0021% of (R – 300) 0.046 °C – 0.0086% of (R – 100)	$R \geq 1000$ °C $300$ °C $\leq R < 1000$ °C $100$ °C $\leq R < 300$ °C	0.001% of span
Type E	0.004 °C + 0.00043% of R		0.001% of span
Type J	0.004 °C + 0.00029% of R 0.004 °C + 0.0020% of abs. val. R	$R \geq 0$ °C $R < 0$ °C	0.001% of span
Type K	0.005 °C + 0.00054% of R 0.005 °C + 0.0020% of abs. val. R	$R \geq 0$ °C $R < 0$ °C	0.001% of span
Type N	0.005 °C + 0.00036% of R	All	0.001% of span
Types R and S	0.015 °C 0.021 °C – 0.0032% of R	$R \geq 200$ °C $R < 200$ °C	0.001% of span
Type T	0.005 °C 0.005 °C + 0.00036% of abs. val. R	$R \geq 0$ °C $R < 0$ °C	0.001% of span
DIN Type L	0.0054 °C + 0.00029% of R 0.0054 °C + 0.0025% of abs. val. R	$R \geq 0$ °C $R < 0$ °C	0.001% of span
DIN Type U	0.0064 °C 0.0064 °C + 0.0043% of abs. val. R	$R \geq 0$ °C $R < 0$ °C	0.001% of span
Type W5Re/W26Re	0.016 °C 0.023 °C + 0.0036% of R	$R \geq 200$ °C $R < 200$ °C	0.001% of span
<b>Millivolt Input</b>	0.00025 mV	Entire Sensor Input Range	0.001% of span
<b>2-, 3-, 4-wire Ohm Input</b>	0.007 $\Omega$	Entire Sensor Input Range	0.001% of span

(1) Change in ambient is in reference to the calibration temperature of the transmitter (20° C [68° F])

(2) Applies to HART / 4-20 mA devices.

Transmitters may be installed in locations where the ambient temperature is between –40 and 85 °C (–40 and 185 °F). To maintain excellent accuracy performance, each transmitter is individually characterized over this ambient temperature range at the factory.

**Temperature Effects Example**

When using a Pt 100 ( $\alpha = 0.00385$ ) sensor input with a 0 to 100 °C span at 30 °C ambient temperature, the following statements would be true:

Digital Temp Effects

- $0.0015^{\circ}\text{C} \times (30 - 20) = 0.015^{\circ}\text{C}$

D/A Effects (HART / 4–20 mA only)

- $[0.01\% \text{ of } 100] \times (30 - 20) = 0.01^{\circ}\text{C}$

Worst Case Error

- Digital + D/A + Digital Temp Effects + D/A Effects =  $0.10^{\circ}\text{C} + 0.02^{\circ}\text{C} + 0.015^{\circ}\text{C} + 0.01^{\circ}\text{C} = 0.145^{\circ}\text{C}$

Total Probable Error

$$\sqrt{0.10^2 + 0.02^2 + 0.015^2 + 0.01^2} = 0.10^{\circ}\text{C}$$

# Rosemount 3144P

## HART / 4–20 MA SPECIFICATIONS

### Power Supply

External power supply required. Transmitters operate on 12.0 to 42.4 V dc transmitter terminal voltage (with 250 ohm load, 18.1 V dc power supply voltage is required). Transmitter power terminals rated to 42.4 V dc.

### Wiring Diagram

See Figure 1 on page 14.

### Alarms

Custom factory configurations of alarm and saturation levels are available for valid values with option code C1. These values can also be configured in the field using a 375 Field Communicator.

### Transient Protection (option code T1)

The transient protector helps to prevent damage to the transmitter from transients induced on the loop wiring by lightning, welding, heavy electrical equipment, or switch gears. The transient protection electronics are contained in an add-on assembly that attaches to the standard transmitter terminal block. The external ground lug assembly (code G1) is included with the Transient Protector. The transient protector has been tested per the following standard:

- IEEE C62.41-1991 (IEEE 587)/ Location Categories B3.  
6kV/3kA peak (1.2 × 50 μS Wave 8 × 20 μS Combination Wave)  
6kV/0.5kA peak (100 kHz Ring Wave)  
EFT, 4kVpeak, 2.5kHz, 5\*50nS
- Loop resistance added by protector: 22 ohms max.
- Nominal clamping voltages: 90 V (common mode), 77 V (normal mode)

### Local Display

Optional five-digit LCD display includes 0–100% bar graph. Digits are 0.4 inches (8 mm) high. Display options include engineering units (°F, °C, °R, K, ohms, and millivolts), percent, and milliamperes. The display can also be set to alternate between engineering units/milliamperes, Sensor 1/Sensor 2, Sensor 1/Sensor 2/Differential Temperature, and Sensor 1/Sensor 2/Average Temperature. All display options, including the decimal point, may be reconfigured in the field using a 375 Field Communicator or AMS.

### Turn-on Time

Performance within specifications is achieved less than 5 seconds (6 seconds for Safety Certified transmitter) after power is applied to the transmitter when the damping value is set to 0 seconds.

### Power Supply Effect

Less than ±0.005% of span per volt.

### SIS Safety Transmitter Failure Values

TÜV IEC 61508 Safety Certified SIL 2 and SIL 3 Claim Limit

- Safety accuracy: 2.0%<sup>(1)</sup> or 2 °C (3.6 °F), whichever is greater
- Safety response time: 5 seconds
- Safety specifications and FMEDA Report available at [www.rosemount.com/safety](http://www.rosemount.com/safety)

(1) A 2% variation of the transmitter mA output is allowed before a safety trip. Trip values in the DCS or safety logic solver should be derated by 2%.

### Temperature Limits

Description	Operating Limit	Storage Limit
Without LCD	–40 to 185 °F	–60 to 250 °F
Display	–40 to 85 °C	–50 to 120 °C
With LCD Meter	–4 to 185 °F	–50 to 185 °F
	–20 to 85 °C	–45 to 85 °C

### HART Communicator Connections

375 Field Communicator connections are permanently fixed to power/signal block.

### Failure Mode

The 3144P features software and hardware failure mode detection. An independent circuit is designed to provide backup alarm output if the microprocessor hardware or software fails. The alarm level is user-selectable using the failure mode switch. If failure occurs, the position of the hardware switch determines the direction in which the output is driven (HIGH or LOW). The switch feeds into the digital-to-analog (D/A) converter, which drives the proper alarm output even if the microprocessor fails. The values at which the transmitter drives its output in failure mode depends on whether it is configured to standard, or NAMUR-compliant (NAMUR recommendation NE 43) operation. The values for standard and NAMUR-compliant operation are as follows:

TABLE 2. Operation Parameters

	Standard <sup>(1)</sup>	NAMUR-Compliant <sup>(1)</sup>
Linear Output:	3.9 ≤ I ≤ 20.5	3.8 ≤ I ≤ 20.5
Fail HIGH:	21.75 ≤ I ≤ 23 (default)	21.5 ≤ I ≤ 23 (default)
Fail Low:	I ≤ 3.75	I ≤ 3.6

(1) Measured in milliamperes

### Load Limitations

Maximum Load = 40.8 X (Supply Voltage - 12.0)<sup>(1)</sup>

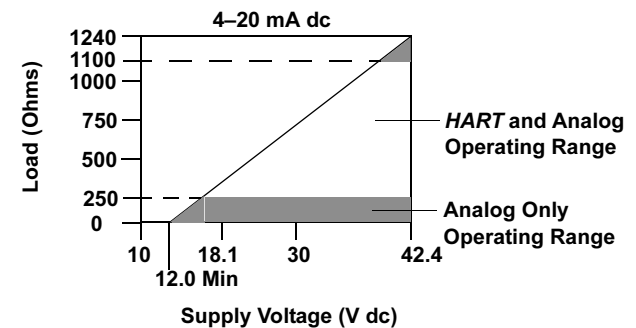

(1) Without transient protection (optional).

### NOTE

HART Communication requires a loop resistance between 250 and 1100 ohms. Do not communicate with the transmitter when power is below 12 V dc at the transmitter terminals.

**FOUNDATION FIELDBUS SPECIFICATIONS**

**Power Supply**

Powered over FOUNDATION Fieldbus with standard fieldbus power supplies. Transmitters operate on 9.0 to 32.0 V dc, 11 mA maximum. Transmitter power terminals are rated to 42.4 V dc.

**Wiring Diagram**

See Figure 2 on page 14.

**Alarms**

The AI function block allows the user to configure the alarms to HIGH-HIGH, HIGH, LOW, or LOW-LOW with a variety of priority levels and hysteresis settings

**Transient Protection (option code T1)**

The transient protector helps to prevent damage to the transmitter from transients induced on the loop wiring by lightning, welding, heavy electrical equipment, or switch gears. The transient protection electronics are contained in an add-on assembly that attaches to the standard transmitter terminal block. The transient terminal block is not polarity insensitive. The transient protector has been tested to the following standard:

- IEEE C62.41-1991 (IEEE 587), Location Categories B3.
- Combinational Wave, 6kV/3kA peak, 1.2\*50uS/8\*20uS.
- Ring Wave, 100kHz, 6kV/0.5kA peak
- EFT, 4kV, 2.5kHz, 5\*50nS
- Loop resistance added by protector: 22 ohms max.
- Nominal clamping voltages:90 V (common mode), 77 V (normal mode)

**Local Display**

Displays all DS\_65 measurements in the Transducer and Function Blocks including Sensor 1, Sensor 2, differential and terminal temperatures. The display alternates up to four selected items. The meter can display up to five digits in engineering units (°F, °C, °R, K, Ω, and millivolts). Display settings are configured at the factory according to the transmitter configuration (standard or custom). These settings can be reconfigured in the field using a 375 Field Communicator or DeltaV. In addition, the LCD provides the ability to display DS\_65 parameters from other devices. In addition to the configuration of the meter, sensor diagnostic data is displayed. If the measurement status is Good, the measured value is shown. If the measurement status is Uncertain, the status indicating uncertain is show in addition to the measured value.If the measurement status is Bad, the reason for the bad measurement is shown.

**Note:** When ordering a spare electronics module assembly, the LCD transducer block will display the default parameter.

**Turn-on Time**

Performance within specifications is achieved less than 20 seconds after power is applied to the transmitter when the damping value is set to 0 seconds.

**Status**

If self-diagnostics detect a sensor burnout or a transmitter failure, the status of the measurement will be updated accordingly. The status may also send the PID output to a safe value.

**FOUNDATION Fieldbus Parameters**

Schedule Entries	25 (max.)
Links	30 (max.)
Virtual Communications Relationships (VCR)	20 (max.)

**Software Upgrade in the Field**

Software for the 3144P with FOUNDATION fieldbus is easy to upgrade in the field. Take advantage of software enhancements by loading new application software into the device memory.

**Backup Link Active Scheduler (LAS)**

The transmitter is classified as a device link master, which means it can function as a Link Active Scheduler (LAS) if the current link master device fails or is removed from the segment. The host or other configuration tool is used to download the schedule for the application to the link master device. In the absence of a primary link master, the transmitter will claim the LAS and provide permanent control for the H1 segment.

**Function Blocks**

**Resource Block**

- Contains physical transmitter information including available memory, manufacture identification, device type, software tag, and unique identification.
- *PlantWeb* Alerts enable the full power of the PW digital architecture by diagnosing instrumentation issues, communicating the details, and recommending a solution.

**Transducer Block**

- Contains the actual temperature measurement data, including sensor 1, sensor 2, and terminal temperature.
- Includes information about sensor type and configuration, engineering units, linearization, range, damping, and diagnostics.

**LCD Block (when an LCD display is used)**

- Configures the local display.

**Analog Input (AI)**

- Processes the measurement and makes it available on the fieldbus segment.
- Allows filtering, engineering unit, and alarm changes.

**PID Block (provides control functionality)**

- Performs single loop, cascade, or feedforward control in the field.

**Instantiable Function Blocks**

- All the function blocks used by the transmitter are instantiable, meaning the total number of function blocks is only limited by the physical memory available in the transmitter. Since only the instantiated blocks can use physical memory, any combination of function blocks can be used at any given time as long as the physical memory size is not violated.

Block	Execution Time
Resource	–
Transducer	–
LCD Block	–
Advanced Diagnostics	–
Analog Input 1, 2, 3	60 milliseconds
PID 1 and 2 with Autotune	90 milliseconds
Input Selector	65 milliseconds
Signal Characterizer	45 milliseconds
Arithmetic	60 milliseconds
Output Splitter	60 milliseconds



## Product Certifications

### ROSEMOUNT 3144P WITH HART / 4–20 mA

#### Approved Manufacturing Locations

Rosemount Inc. – Chanhassen, Minnesota, USA  
Rosemount Temperature GmbH – Germany  
Emerson Process Management Asia Pacific – Singapore

#### European Union Directive Information

The EC declaration of conformity for all applicable European Directives for this product can be found on the Rosemount website at [www.rosemount.com](http://www.rosemount.com). A hard copy may be obtained by contacting an Emerson Process Management representative.

#### ATEX Directive (94/9/EC)

Rosemount Inc. complies with the ATEX Directive.

#### Electro Magnetic Compatibility (EMC) (89/336/EEC)

EN 50081-1: 1992; EN 50082-2:1995; EN 61326-1:1997 – Industrial

#### Hazardous Locations Installations

##### North American Certifications

##### Factory Mutual (FM) Approvals

- I5 FM Intrinsic Safety and Non-incendive:  
Intrinsically Safe for Class I/II/III, Division 1, Groups A, B, C, D, E, F, and G.  
Temperature codes: T4A ( $T_{amb} = -60$  to  $60$  °C)  
T5 ( $T_{amb} = -60$  to  $50$  °C)  
Zone Marking: Class I, Zone 0, AEx ia IIC  
T4 ( $T_{amb} = -50$  to  $60$  °C)  
Intrinsically Safe when installed in accordance with control drawing 03144-0321.  
Non-incendive for use in Class I, Division 2, Groups A, B, C, and D. Suitable for use in Class II / III, Division 2, Groups F and G. Non-incendive when installed in accordance with Rosemount drawings 03144-0321.  
Temperature codes: T6 ( $T_{amb} = -60$  to  $60$  °C),  
T5 ( $T_{amb} = -60$  to  $85$  °C)
- E5 Explosion Proof for Class I, Division 1, Groups A, B, C, D. Dust Ignition-Proof for use in Class II/III, Division 1, Groups E, F, and G. Explosion-Proof and Dust Ignition-Proof when installed in accordance with Rosemount drawing 03144-0320. Indoor and outdoor use. NEMA Type 4X.  
Temperature code: T5 ( $T_{amb} = -50$  to  $85$  °C)

#### NOTE

For Group A, seal all conduits within 18 inches of enclosure; otherwise, conduit seal not required for compliance with NEC 501-5a(1).

Non-incendive for use in Class I, Division 2, Groups A, B, C, and D. Suitable for use in Class II/III, Division 2, Groups F and G. Non-incendive when installed in accordance with Rosemount drawing 03144-0321.

Temperature codes: T5 ( $T_{amb} = -60$  to  $85$  °C),  
T6 ( $T_{amb} = -60$  to  $60$  °C)

##### Canadian Standards Association (CSA) Approvals

- I6 CSA Intrinsic Safety and Division 2  
Intrinsically Safe for Class I, Division 1, Groups A, B, C, and D; Class II, Division 1, Groups E, F, and G; Class III, Division 1; Suitable for Class I, Division 2, Groups A, B, C, and D. Intrinsically Safe and Division 2 when installed per Rosemount drawing 03144-0322.
- K6 Combination of I6 and the following:  
Explosion Proof for Class I, Division 1, Groups A, B, C, and D; Class II, Division 1, Groups E, F, and G; Class III, Division 1 hazardous locations. Factory sealed.

##### European Certifications

- E1 ATEX Flameproof Approval (Zone 1)  
Certificate Number: KEMA01ATEX2181  
ATEX Category Marking  $\text{Ex}$  II 2 G  
EEx d IIC T6 ( $T_{amb} = -40$  to  $70$  °C)  
EEx d IIC T5 ( $T_{amb} = -40$  to  $80$  °C)  
Max supply voltage: 55 Vdc
  - ND ATEX Dust Ignition Proof Approval  
Certificate Number: KEMA01ATEX2205  
ATEX Category Marking  $\text{Ex}$  II 1 D  
T95 °C ( $T_{amb} = -40$  to  $85$  °C)  
Max supply voltage: 55 Vdc
  - N1 ATEX Type n Approval (Zone 2)  
Certificate Number: BAS01ATEX3432X  
ATEX Category Marking  $\text{Ex}$  II 3 G  
EEx nL IIC T6 ( $T_{amb} = -40$  to  $50$  °C)  
EEx nL IIC T5 ( $T_{amb} = -40$  to  $75$  °C)  
 $U_i = 55V$
- Special Conditions for Safe Use (X):**  
The transmitter is not capable of withstanding the 500 v insulating test required by Clause 9.1 of EN50021:1999. This condition must be taken into account during installation.
- I1 ATEX Intrinsic Safety Approval (Zone 0)  
Certificate Number: BAS01ATEX1431X  
ATEX Category Marking  $\text{Ex}$  II 1 G  
EEx ia IIC T6 ( $T_{amb} = -60$  to  $50$  °C)  
EEx ia IIC T5 ( $T_{amb} = -60$  to  $75$  °C)

TABLE 3. Input Entity Parameters

Power/Loop	Sensor
$U_i = 30$ V dc	$C_i = 5$ nF
$I_i = 300$ mA	$L_i = 0$
$P_i = 1.0$ W	
	$U_o = 13.6$ V
	$C_i = 78$ nF
	$I_o = 56$ mA
	$L_i = 0$
	$P_o = 190$ mW

##### Special Conditions for Safe Use (x):

The transmitter is not capable of withstanding the 500V insulation test as defined in Clause 6.4.12 of EN50 020. This condition must be taken into account during installation.



**Australian Certifications**

*Standard Australia Quality Assurance Services (SAA)*

- E7 Flameproof Approval  
Certificate Number: AUS Ex 02.3813X  
Ex d IIC T6 (T<sub>amb</sub> = -20 to 60 °C)  
IP66

**Special Conditions for Safe Use (x):**

1. Apparatus must be installed in accordance to Rosemount drawing 03144-0325.
2. If the sensor is intended to be remote mounted, it should be installed in a suitable Standards Australia certified Flame-Proof enclosure and installed in accordance with Rosemount drawing 03144-0325.
3. Standards Australia certified cable glands or conduit adapters must be used when connecting to external circuits. Where only one conduit entry is used for connection to external circuits, the unused entry is to be closed by means of a blanking plug supplied by Rosemount or by a suitable Standards Australia certified blanking plug.

- N7 Type N Approval  
Certificate Number: AUS Ex 02.3794X  
Ex n IIC T6 (T<sub>amb</sub> = -60 to 50 °C)  
Ex n IIC T5 (T<sub>amb</sub> = -60 to 75 °C)  
IP66  
U<sub>n</sub> = 55 V  
P<sub>n</sub> = 1.3 W

- I7 Intrinsic Safety Approval  
Certificate Number: AUS Ex 02.3794X  
Ex ia IIC T6 (T<sub>amb</sub> = -60 to 50 °C)  
Ex ia IIC T5 (T<sub>amb</sub> = -60 to 75 °C)

TABLE 4. Input Entity Parameters

Power/Loop		Sensor	
U <sub>i</sub> = 30 V dc	C <sub>i</sub> = 0.005 µF	U <sub>o</sub> = 13.6 V	C <sub>o</sub> = 0.66 µF
I <sub>i</sub> = 300 mA	L <sub>i</sub> = 20 µH	I <sub>o</sub> = 100 mA	L <sub>o</sub> = 1.9 mH
P <sub>i</sub> = 1.0 W		P <sub>o</sub> = 80 mW	

**Special Conditions for Safe Use (x):**

1. For options using the transient protection board, the apparatus should be connected to earth with a copper conductor of 4 mm<sup>2</sup> or greater.
2. For the label with more than one type of marking on it, upon completion of commissioning the apparatus the irrelevant marking code(s) shall be permanently scribed off.

**Brazilian Certifications**

*Centro de Pesquisas de Energia Eletrica (CEPEL) Approval*

- I2 CEPEL Intrinsic Safety – Consult factory for availability.

**Japanese Certifications**

*Japanese Industrial Standard (JIS) Flameproof Certification*

- E4 Without sensor: Ex d IIB T6 (T<sub>amb</sub> = -20 to 55 °C)  
With sensor: Ex d IIB T4 (T<sub>amb</sub> = -20 to 55 °C)

**Combination Certifications**

Stainless steel certification tag is provided when optional approval is specified. Once a device labeled with multiple approval types is installed, it should not be reinstalled using any other approval types. Permanently mark the approval label to distinguish it from unused approval types.

- KA Combination of K1 and K6
- KB Combination of K5 and K6
- K1 Combination of E1, N1, and I1
- K7 Combination of E7, N7, and I7
- K5 Combination of I5 and E5

**Additional Certifications**

*American Bureau of Shipping (ABS) Type Approval*

ABS Type Approval for temperature measurements in hazardous locations on ABS Classed Vessels, Marine and Offshore Installations. Type Approval is based on Factory Mutual (FM) Approvals; therefore, specify order code K5. Please contact an Emerson Process Management representative if a copy of the certification is required.

*Det Norske Veritas (DNV) Type Approval for Shipboard and Offshore Installations*

DNV rules for classifications of ships and mobile offshore units for temperature measurements in the following locations:

TABLE 5. Applications / Limitations

Location	Class
Temperature	D
Humidity	B
Vibration	B/C
Enclosure	D

**NOTE**

The transient protector (option code T1) is required when requesting DNV Type Approval. Additionally, hazardous locations approvals may be required (based on shipboard location) and will need to be specified by the Hazardous Locations option code.

Please contact an Emerson Process Management representative if a copy of the certification is required.

**GOSTANDART**

Tested and approved by Russian Metrological Institute

HART  
4-20 mA

# Rosemount 3144P

## ROSEMOUNT 3144P WITH FOUNDATION FIELDBUS

### Approved Manufacturing Locations

Rosemount Inc. – Chanhassen, Minnesota, USA  
 Rosemount Temperature GmbH – Germany  
 Emerson Process Management Asia Pacific – Singapore

### European Union Directive Information

The EC declaration of conformity for all applicable European Directives for this product can be found on the Rosemount website at [www.rosemount.com](http://www.rosemount.com). A hard copy may be obtained by contacting an Emerson Process Management representative.

### ATEX Directive (94/9/EC)

Rosemount Inc. complies with the ATEX Directive.

### Electro Magnetic Compatibility (EMC) (89/336/EEC)

EN 50081-1: 1992; EN 50082-2:1995; EN 61326-1:1997 – Industrial

### Hazardous Locations Installations

#### North American Certifications

##### Factory Mutual (FM) Approvals

I5 FM Intrinsic Safety / FISCO and Non-incendive Intrinsically Safe / FISCO for use in Class I, II, III, Division 1, Groups A, B, C, D, E, F, and G;  
 Temperature code: T4 ( $T_{amb} = -60\text{ °C to }60\text{ °C}$ )  
 Zone marking: Class I, Zone 0, AEx ia IIC T4 ( $T_{amb} = -50\text{ °C to }60\text{ °C}$ )  
 Intrinsically safe when installed in accordance with control drawing 003144-5075.

Non-incendive for use in Class, Division 2, Groups A,B,C and D; Suitable for use in Class II/III, Division 2, Groups F and G  
 Non-incendive when installed in accordance with Rosemount drawing 03144-5075.

Temperature Class: T6 ( $T_{amb} = -60\text{ °C to }50\text{ °C}$ );  
 T5 ( $T_{amb} = -60\text{ °C to }75\text{ °C}$ )

E5 Explosion Proof for Class I, Division 1, Groups A, B, C, and D.  
 Dust Ignition-Proof for use in Class II/III, Division 1, Groups E, F, and G. Explosion-Proof and Dust Ignition-Proof when installed in accordance with Rosemount drawing 03144-0320. Indoor and outdoor use. NEMA Type 4X.  
 Temperature code: T5 ( $T_{amb} = -50\text{ to }85\text{ °C}$ )

#### NOTE

For Group A, seal all conduits within 18 inches of enclosure; otherwise, conduit seal not required for compliance with NEC 501-5a(1).

Non-incendive for use in Class I, Division 2, Groups A, B, C, and D. Suitable for use in Class II/III, Division 2, Groups F and G. Non-incendive when installed in accordance with Rosemount drawing 03144-5075.

Temperature codes: T5 ( $T_{amb} = -60\text{ to }75\text{ °C}$ ),  
 T6 ( $T_{amb} = -60\text{ to }50\text{ °C}$ )

#### Canadian Standards Association (CSA) Approvals

I6 CSA Intrinsic Safety / FISCO and Division 2 Intrinsically Safe / FISCO for use in Class I, Division 1, Groups A, B, C, and D; Class II, Division 1, Groups E, F, and G; Class III, Division 1.

Temperature Class: T4 ( $T_{amb} = -50\text{ °C to }60\text{ °C}$ )  
 Suitable for Class I, Division 2, Groups A, B, C, and D.

Temperature Class: T5 ( $T_{amb} = -60\text{ °C to }85\text{ °C}$ );  
 T6 ( $T_{amb} = -60\text{ °C to }60\text{ °C}$ )

Intrinsic Safety / FISCO and Division 2 when installed per Rosemount drawing 03144-5076.

K6 Combination of I6 and the following:  
 Explosion Proof for Class I, Division 1, Groups A, B, C, and D; Class II, Division 1, Groups E, F, and G; Class III, Division 1 hazardous locations. Factory sealed.

# Product Data Sheet

00813-0100-4021, Rev EA

November 2004

# Rosemount 3144P

## European Certifications

- E1 ATEX Flameproof Approval (Zone 1)  
Certificate Number: KEMA01ATEX2181  
ATEX Category Marking  $\text{Ex}$  II 2 G  
EEx d IIC T6 ( $T_{\text{amb}} = -40$  to  $70$  °C)  
EEx d IIC T5 ( $T_{\text{amb}} = -40$  to  $80$  °C)  
Max supply voltage: 55 Vdc
- ND ATEX Dust Ignition Proof Approval  
Certificate Number: KEMA01ATEX2205  
ATEX Category Marking  $\text{Ex}$  II 1 D  
 $T_{95}$  °C ( $T_{\text{amb}} = -40$  to  $85$  °C)  
Max supply voltage: 55 Vdc
- N1 ATEX Type n Approval (Zone 2)  
Certificate Number: Baseefa03ATEX0709  
ATEX Category Marking  $\text{Ex}$  II 3 G  
EEx nA nL IIC T5 ( $T_{\text{amb}} = -40$  to  $75$  °C)  
 $U_i = 42.4$  V maximum
- I1 ATEX Intrinsic Safety / FISCO  
Approval (Zone 0)  
Certificate Number: Baseefa03ATEX0708X  
ATEX Category Marking  $\text{Ex}$  II 1 G  
EEx ia IIC T4 ( $T_{\text{amb}} = -60$  to  $60$  °C)

TABLE 6. Input Entity Parameters

Power/Loop	FISCO Power/Loop	Sensor
$U_i = 30$ V dc	$U_i = 17.5$ V dc	$U_o = 13.9$ V
$I_i = 300$ mA	$I_i = 380$ mA	$I_o = 23$ mA
$P_i = 1.3$ W	$P_i = 5.32$ W	$P_o = 79$ mW
$C_i = 2.1$ nF	$C_i = 2.1$ nF	$C_i = 7.7$ nF
$L_i = 0$	$L_i = 0$	$L_i = 0$

### Special Conditions for Safe Use (x):

- The apparatus enclosure may contain light metals. The apparatus must be installed in such a manner as to minimize the risk of impact or friction with other metal surfaces.
- A Transient protection device can be fitted as an option, in which the equipment will not pass the 500V test.

## Australian Certifications

Standard Australia Quality Assurance Services (SAA)

- E7 Flameproof Approval  
Certificate Number: AUS Ex 02.3813X  
Ex d IIC T6 ( $T_{\text{amb}} = -20$  to  $60$  °C)  
IP66
- Special Conditions for Safe Use (x):**
- Apparatus must be installed in accordance to Rosemount drawing 03144-0325.
  - If the sensor is intended to be remote mounted, it should be installed in a suitable Standards Australia certified Flame-Proof enclosure and installed in accordance with Rosemount drawing 03144-0325.
  - Standards Australia certified cable glands or conduit adapters must be used when connecting to external circuits. Where only one conduit entry is used for connection to external circuits, the unused entry is to be closed by means of a blanking plug supplied by Rosemount or by a suitable Standards Australia certified blanking plug.
- N7 Type n Approval (Zone 2)  
Certificate Number: AUS Ex 02.3794X  
Ex n IIC T5 ( $T_{\text{amb}} = -60$ °C to  $75$ °C)  
Ex n IIC T6 ( $T_{\text{amb}} = -60$ °C to  $50$ °C)  
IP66

### Special Conditions for Safe Use:

- For the lightning protection board, the apparatus should be bonded to earth with a copper conductor of  $4\text{mm}^2$  or greater.
- Input/Output parameters for non-sparking protection model Ex n: Maximum input voltage  $U_n = 55\text{V}$ .  
Maximum input power  $P_n = 1.3\text{W}$ .

## Brazilian Certifications

Centro de Pesquisas de Energia Eletrica (CEPEL)  
Approval

- I2 CEPEL Intrinsic Safety – Consult factory for availability.

## Japanese Certifications

Japanese Industrial Standard (JIS) Flameproof  
Certification

- E4 Consult factory for availability.

## Combination Certifications

Stainless steel certification tag is provided when optional approval is specified. Once a device labeled with multiple approval types is installed, it should not be reinstalled using any other approval types. Permanently mark the approval label to distinguish it from unused approval types.

- KA Combination of K1 and K6
- KB Combination of K5 and K6
- K1 Combination of E1, N1, and I1
- K7 Combination of E7, N7, and I7
- K5 Combination of I5 and E5.

## Dimensional Drawings

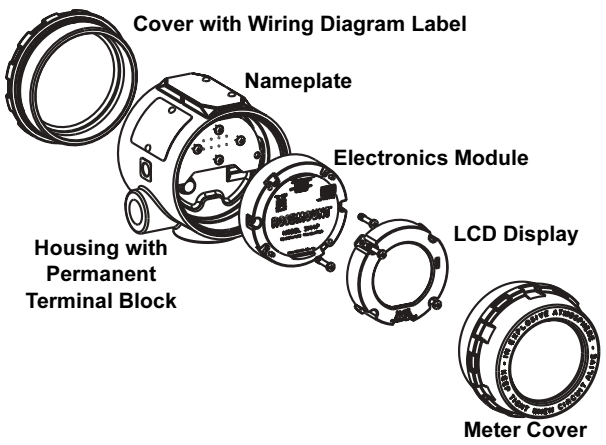
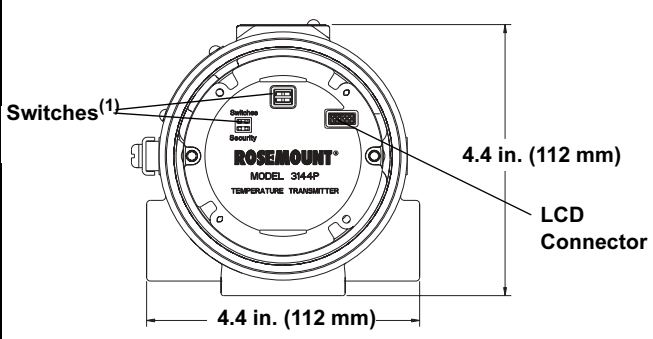
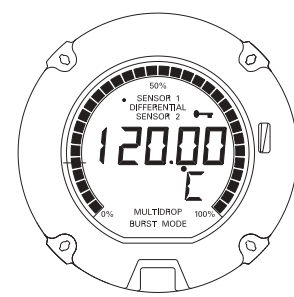
Transmitter Exploded View	Switch Location
 <p>Cover with Wiring Diagram Label</p> <p>Nameplate</p> <p>Electronics Module</p> <p>LCD Display</p> <p>Housing with Permanent Terminal Block</p> <p>Meter Cover</p>	 <p>Switches (1)</p> <p>4.4 in. (112 mm)</p> <p>LCD Connector</p> <p>4.4 in. (112 mm)</p> <p>(1) Alarm and Write Protect (HART), Simulate and Write Protect (FOUNDATION Fieldbus)</p>
<b>LCD Display Faceplate</b>	
	

3144-0001B01B

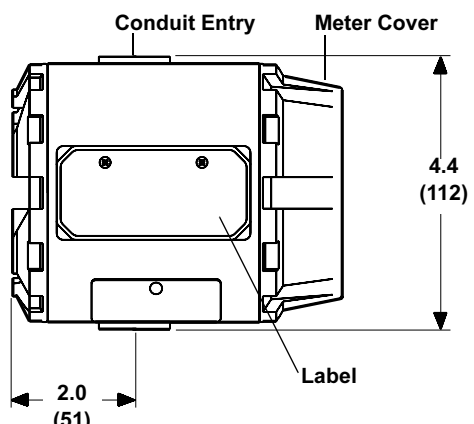
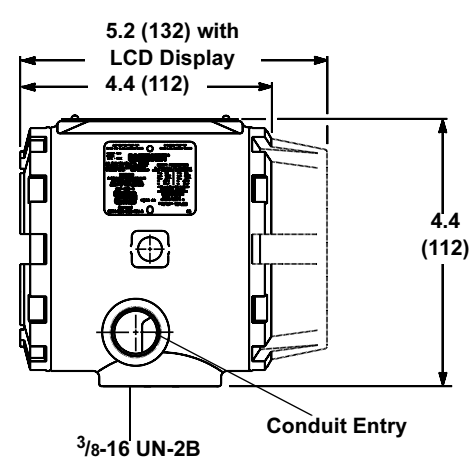
<b>Transmitter Dimensional Drawing</b>	
Top View	Side View
 <p>Conduit Entry</p> <p>Meter Cover</p> <p>4.4 (112)</p> <p>2.0 (51)</p> <p>Label</p>	 <p>5.2 (132) with LCD Display</p> <p>4.4 (112)</p> <p>4.4 (112)</p> <p>3/8-16 UN-2B</p> <p>Conduit Entry</p>
Dimensions are in inches (millimeters)	

3144-0204B02A, 0000A07A

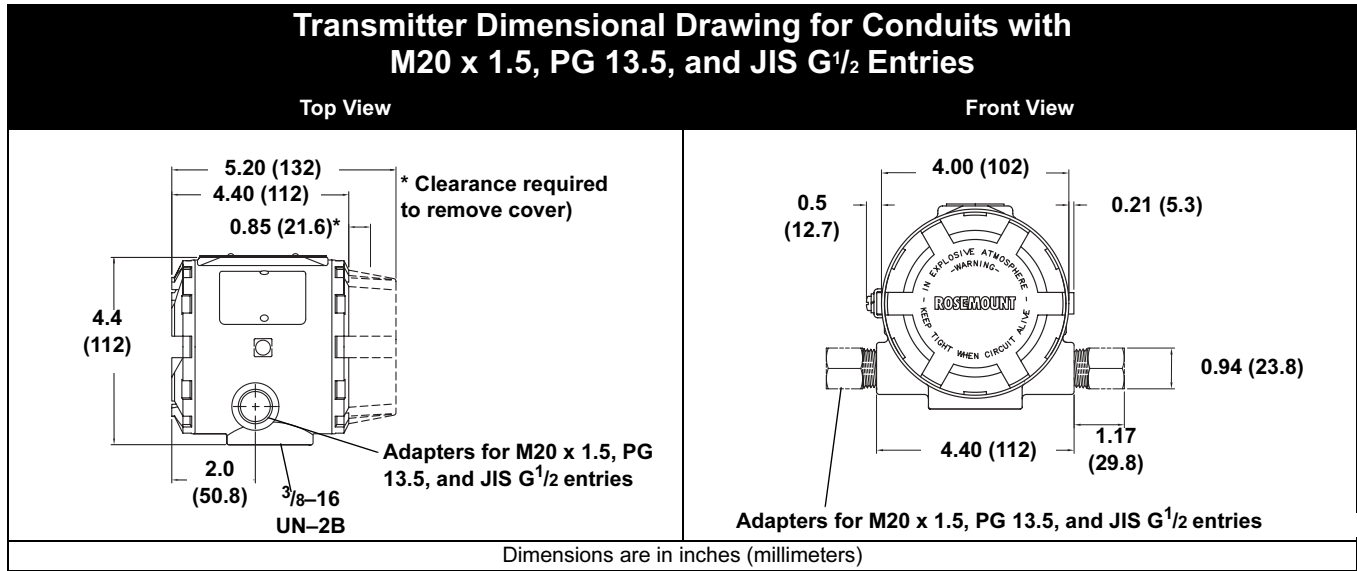

3144-3144A021A, A022A

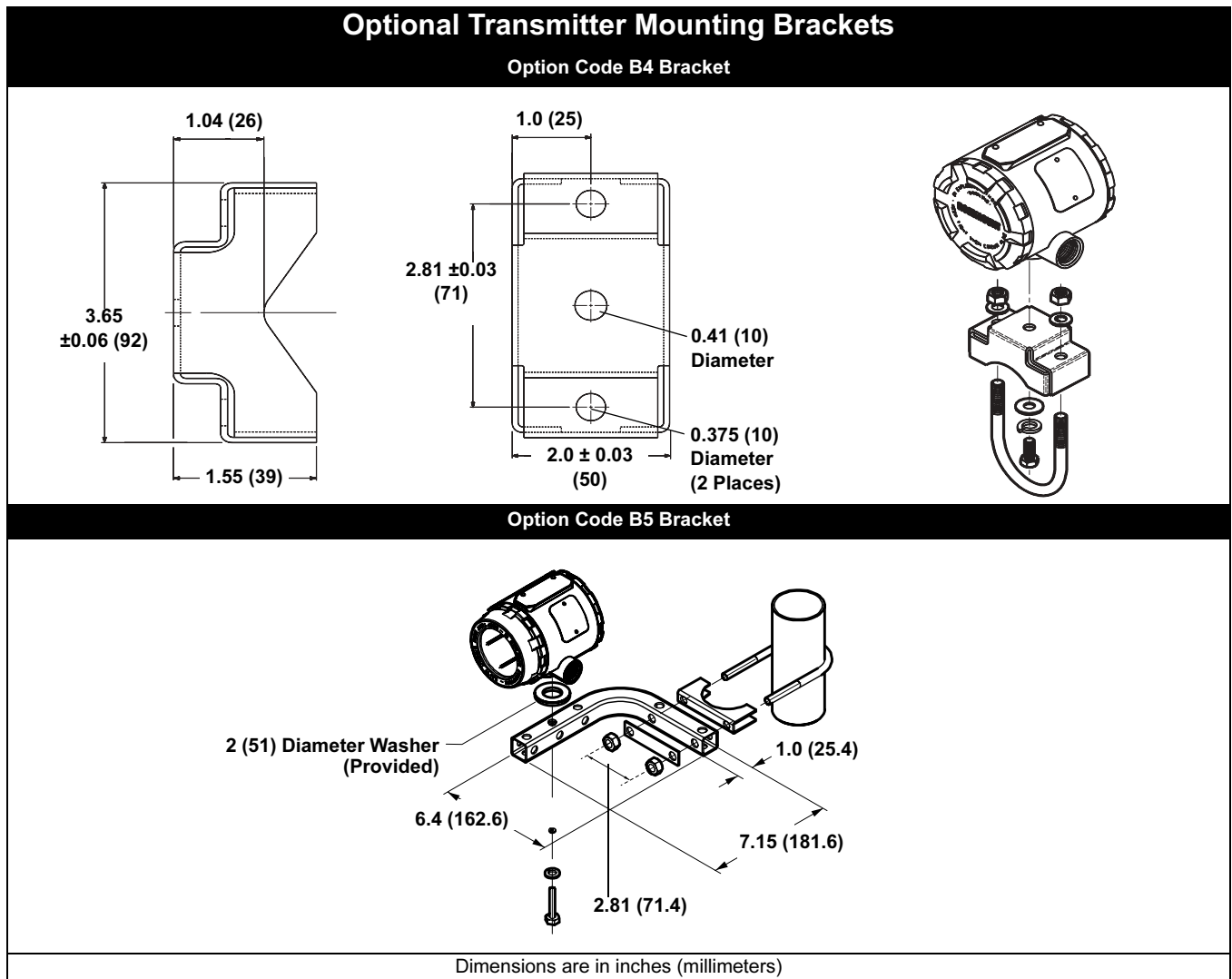

3044-2101A01A; B01B; 3144-3144A14A,

3144- 1081A01A

FIGURE 1. HART / 4–20 mA

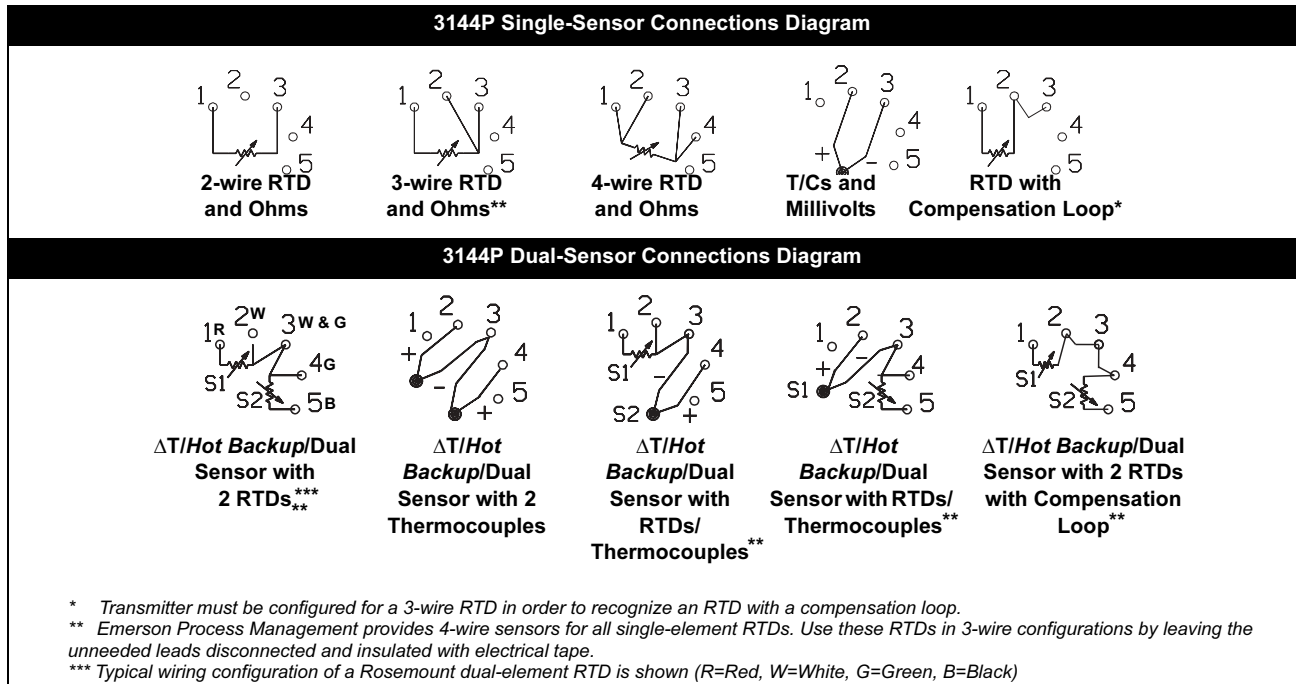
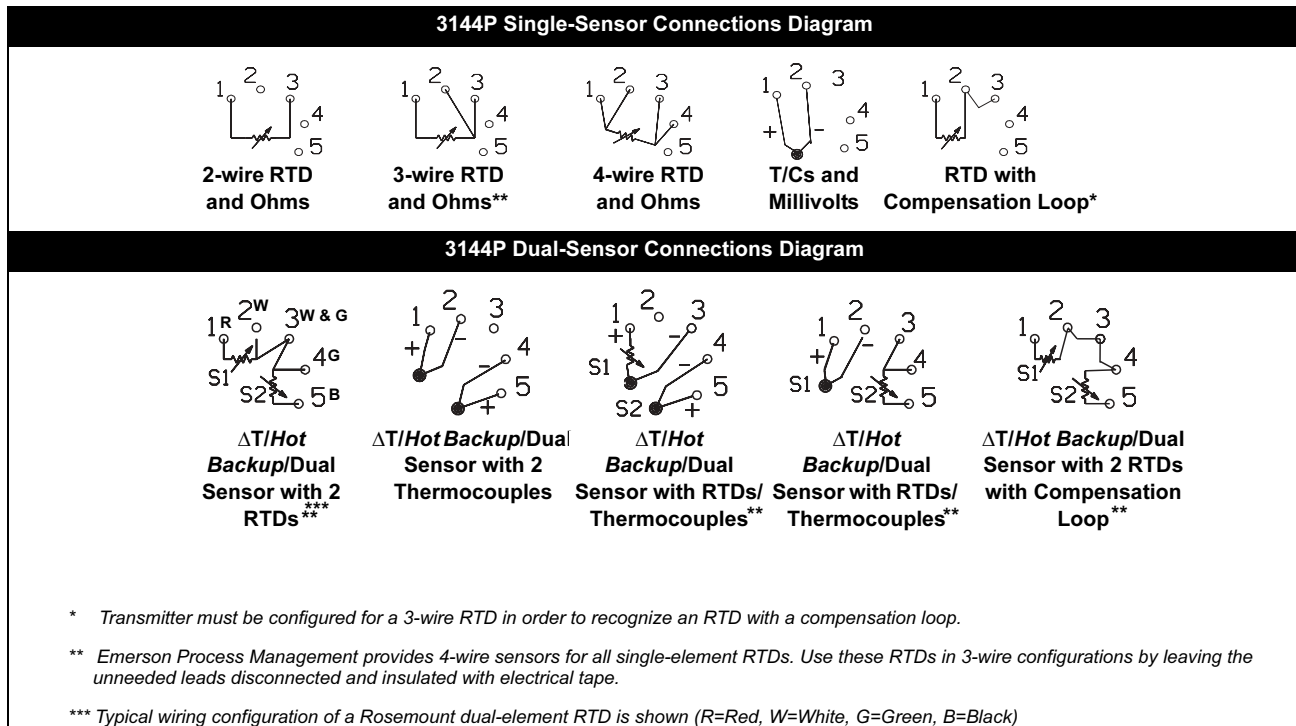

FIGURE 2. FOUNDATION Fieldbus



## Ordering Information

Model	Product Description
3144P	Temperature Transmitter
Transmitter Housing Type/Conduit Entry	
D1	Field Mount Housing (Dual-Compartment), Aluminum, 1/2-14 NPT
D2	Field Mount Housing (Dual-Compartment), Aluminum, M20 x 1.5 (CM20)
D3	Field Mount Housing (Dual-Compartment), Aluminum, PG 13.5 (PG11)
D4	Field Mount Housing (Dual-Compartment), Aluminum, JIS G 1/2
D5	Field Mount Housing (Dual-Compartment), Stainless Steel, 1/2-14 NPT
D6	Field Mount Housing (Dual-Compartment), Stainless Steel, M20 x 1.5 (CM20)
D7	Field Mount Housing (Dual-Compartment), Stainless Steel, PG 13.5 (PG11)
D8	Field Mount Housing (Dual-Compartment), Stainless Steel, JIS G 1/2
Code	Output
A	4-20 mA with Digital Signal based on <i>HART</i> protocol
B	4 – 20 mA Safety Certified with digital signal based on <i>HART</i> protocol
F	<i>FOUNDATION</i> fieldbus digital signal (includes 3 AI function blocks and Backup Link Active Scheduler)
Code	Measurement Type Configuration
1	Single-Sensor Input
2	Dual-Sensor Input
Code	Product Certifications
NA	No Approval
E5	FM explosion-proof and non incensive approval
I5 <sup>(1)</sup>	FM intrinsic safety and non-incensive (includes standard I.S. and FISCO for fieldbus units)
K5 <sup>(1)</sup>	FM intrinsic safety, non-incensive, and explosion-proof combination (includes standard I.S. and FISCO for fieldbus units)
KB <sup>(1)</sup>	FM and CSA intrinsic safety, explosion-proof & non-incensive combination (includes standard IS and FISCO for fieldbus units)
I6 <sup>(1)</sup>	CSA intrinsic safety and FISCO Division 2 (includes standard IS and FISCO for fieldbus units)
K6 <sup>(1)</sup>	CSA intrinsic safety, FISCO Division 2, and explosion-proof combination (includes standard IS and FISCO for fieldbus units)
E1	ATEX flameproof approval
N1	ATEX type n approval
I1 <sup>(1)</sup>	ATEX intrinsic safety (includes standard I.S. and FISCO for fieldbus units)
K1 <sup>(1)</sup>	ATEX intrinsic safety, flameproof, and Type n approval combination (includes standard IS and FISCO for fieldbus units)
ND	ATEX dust ignition proof approval
KA <sup>(1)</sup>	ATEX/CSA intrinsic safety and explosion-proof combination (includes standard I.S. and FISCO for fieldbus units.)
E7	SAA flameproof approval
N7	SAA type n approval
I7 <sup>(1)(2)</sup>	SAA intrinsic safety – <i>HART</i> only
K7 <sup>(1)(3)</sup>	SAA intrinsic safety, flameproof, and type n combination (includes standard IS & FISCO for FF)–consult for fieldbus availability
I2 <sup>(2)</sup>	CEPEL intrinsic safety approval
E4 <sup>(2)</sup>	JIS flameproof approval (requires either housing code D4 or D8)

Code	Options
<b>PlantWeb Functionality</b>	
A01	Regulatory control suite: PID with autotune, arithmetic, signal characterizer, input selector – FOUNDATION fieldbus only
D01	Diagnostics suite: SPM diagnostics, drift alert – FOUNDATION fieldbus only
<b>Mounting Bracket</b>	
B4	Universal mounting bracket for 2-inch pipe and panel mounting—SST bracket and bolts
B5	Universal “L” mounting bracket for 2-inch pipe mounting—SST bracket and bolts
<b>Meter</b>	
M5	LCD display
<b>External Ground Lug</b>	
G1	External ground lug assembly (See “External Ground Screw Assembly” on page 3.)
<b>Integral Transient Protector</b>	
T1	Integral transient protector
<b>Custom Software Configuration Request</b>	
C1 <sup>(3)</sup>	Factory enters date, descriptor, and message fields (CDS required with order)
<b>50 Hz Line Voltage Filter Enabled</b>	
F5	50 Hz line voltage filter
<b>NAMUR Compliant Alarm Failure</b>	
A1	Analog output levels compliant with NAMUR recommendation NE-43, June 1996. Alarm configuration <b>high</b> – HART only
CN	Analog output levels compliant with NAMUR recommendation NE-43, June 1996. Alarm configuration <b>low</b> – HART only
<b>Low Alarm</b>	
C8	Analog output levels compliant with Rosemount standard. Alarm configuration <b>low</b> – HART only
<b>Transmitter-Sensor Matching</b>	
C2	Transmitter-Sensor Matching—trim to specific Rosemount RTD calibration schedule
C7	Trim to special non-standard sensor (special sensor—customer must provide sensor information)
<b>Five Point Calibration Data</b>	
C4	5-point calibration (use option code Q4 to generate a calibration certificate)
<b>Calibration Certification</b>	
Q4	Calibration certificate (3-point standard; use code C4 with Q4 option for a five point calibration certificate)
QP	Calibration certificate and tamper evident seal
<b>Dual-Input Custom Configuration (only with measurement type option code 2)</b>	
U1 <sup>(4)</sup>	<i>Hot Backup</i>
U2	Average temperature with <i>Hot Backup</i> and Sensor Drift Alert – warning mode
U3 <sup>(5)</sup>	Average temperature with <i>Hot Backup</i> and Sensor Drift Alert – alarm mode
U4	Two independent sensors
U5	Differential temperature
U6 <sup>(4)</sup>	Average temperature
U7 <sup>(4)</sup>	First good temperature
U8 <sup>(4)</sup>	Minimum temperature – FOUNDATION fieldbus only
U9 <sup>(4)</sup>	Maximum temperature – FOUNDATION fieldbus only
<b>Special Certifications</b>	
QS	Quality Documentation for Safety Instrumented Systems – HART only
<b>Conduit Electrical Connector</b>	
GE <sup>(6)</sup>	M12, 4-pin, Male Connector ( <i>eurofast</i> <sup>®</sup> )
GM <sup>(6)</sup>	A size Mini, 4-pin, Male Connector ( <i>minifast</i> <sup>®</sup> )
<b>Assembly</b>	
XA	Sensor specified separately and assembled to transmitter
<b>Typical Model Number: 3144P D1 A 1 E5 B4 M5</b>	

(1) When IS approval is ordered on a FOUNDATION fieldbus, both standard IS and FISCO IS approvals apply. The device label is marked appropriately.

(2) Consult factory for availability when ordering with HART or FOUNDATION fieldbus models.

(3) Consult factory for availability when ordering with FOUNDATION fieldbus models.

(4) Codes U1 and U6 for HART transmitters will not have drift alert enabled; option codes U1, U6, U7, U8, and U9 for Foundation fieldbus transmitters will have drift alert enabled.

(5) Available only on Safety Certified transmitter output code B.

(6) Not available with certain hazardous location certifications. Contact an Emerson Process Management representative for details.



**Standard Configuration**

Both standard and custom configuration settings may be changed. Unless specified, the transmitter will be shipped as follows:

Standard Configuration	
4 mA value / Lower Range (HART / 4–20 mA)	0 °C
20 mA value / Upper Range (HART / 4–20 mA)	100 °C
Damping	5 seconds
Output	Linear with temperature / FOUNDATION fieldbus
Failure Mode (HART / 4–20 mA)	High
Line Voltage Filter	60 Hz
Software Tag	See "Tagging"
Optional Integral Meter	Units and mA / Sensor 1 units
Single Sensor option	
Sensor Type	4-wire Pt 100 $\alpha = 0.00385$ RTD
Primary Variable (HART / 4–20 mA)	Sensor 1
Secondary Variable	Terminal Temperature
Tertiary Variable	Not Available
Quaternary Variable	Not Available
Dual-Sensor option	
Sensor Type	Two 3-wire Pt 100 $\alpha = 0.00385$ RTD
Primary Variable (HART / 4–20 mA)	Sensor 1
Secondary Variable	Sensor 2
Tertiary Variable	Terminal Temperature
Quaternary Variable	Not Used

**Custom Configuration**

The 3144P transmitter can be ordered with custom configuration. The table below lists the requirements necessary to specify a custom configuration.

Option Code	Requirements/Specification
C1: Factory Data <sup>(1)</sup>	Date: day/month/year Descriptor: 16 alphanumeric character Message: 32 alphanumeric character Custom Alarm Levels can be specified for configuration at the factory.
C2: Transmitter Sensor Matching	The transmitters are designed to accept Callendar-van Dusen constants from a calibrated RTD schedule and generate a custom curve to match any specific sensor curve. Specify a Series 68, 65, or 78 RTD sensor on the order with a special characterization curve (V or X8Q4 option). These constants will be programmed into the transmitter with this option.
C4: Five Point Calibration	Will include five-point calibration at 0, 25, 50, 75, and 100% analog and digital output points. Use with option code Q4 to obtain a Calibration Certificate.
C7: Special Sensor	Used for non-standard sensor, adding a special sensor or expanding input. Customer must supply the non-standard sensor information. Additional special curve will be added to sensor curve input choices.
A1: NAMUR-Compliant, high alarm	Analog output levels compliant with NAMUR. Alarm is set to fail high.
CN: NAMUR-Compliant, low alarm	Analog output levels compliant with NAMUR. Alarm is set to fail low.
C8: Low Alarm	Analog output levels compliant with Rosemount standard. Alarm is set to fail low
F5: 50 Hz Line Filter	Calibrated to 50 Hz line voltage filter.

(1) CDS required

# Rosemount 3144P

To custom configure the 3144P with the dual-sensor option transmitter for one of the applications described below, indicate the appropriate option code in the model number. If a sensor type is not specified, the transmitter will be configured for two 3-wire Pt 100 ( $\alpha = 0.00385$ ) RTDs if any of the following option codes are selected.

**Option Code U1: Hot Backup**

Primary Usage	Primary usage sets the transmitter to automatically use sensor 2 as the primary input if sensor 1 fails. Switching from sensor 1 to sensor 2 is accomplished without any effect on the analog signal.
Primary Variable	1st good
Secondary Variable	Sensor 1
Tertiary Variable	Sensor 2
Quaternary Variable	Terminal Temperature

**Option Code U2: Average Temperature with Hot Backup and Sensor Drift Alert – Warning Mode**

Primary Usage	Critical applications, such as safety interlocks and control loops. Outputs the average of two measurements and alerts if temperature difference exceeds the set maximum differential (Sensor Drift Alert – warning mode). If a sensor fails, an alert will be sent digitally. The primary variable will be reported as the remaining working sensor value.
Primary Variable	Sensor Average
Secondary Variable	Sensor 1
Tertiary Variable	Sensor 2
Quaternary Variable	Terminal Temperature

**Option Code U3: Average temperature with Hot Backup and Sensor Drift Alert – Alarm Mode**

Primary Usage	Critical applications, such as safety interlocks and control loops. Outputs the average of two measurements and alarms if temperature difference exceeds the set maximum differential (Sensor Drift Alert – alarm mode). If a sensor fails, an alert will be sent digitally. The primary variable will be reported as the remaining working sensor value.
Primary Variable	Sensor Average
Secondary Variable	Sensor 1
Tertiary Variable	Sensor 2
Quaternary Variable	Terminal Temperature

**Option Code U4: Two Independent Sensors**

Primary Usage	Used in non-critical applications where the digital output is used to measure two separate process temperatures.
Primary Variable	Sensor 1
Secondary Variable	Sensor 2
Tertiary Variable	Terminal Temperature
Quaternary Variable	Not Used

**Option Code U5 Differential Temperature**

Primary Usage	The differential temperature of two process temperatures is configured as the primary variable.
Primary Variable	Differential Temperature
Secondary Variable	Sensor 1
Tertiary Variable	Sensor 2
Quaternary Variable	Terminal Temperature

**Option Code U6: Average Temperature**

Primary Usage	When average measurement of two different process temperatures is required. If a sensor fails, an alert will be sent and the primary variable will use the measurement of the working sensor.
Primary Variable	Sensor Average
Secondary Variable	Sensor 1
Tertiary Variable	Sensor 2
Quaternary Variable	Terminal Temperature

## **Configuration Data Sheets**

## HART / 4–20 mA / AND SAFETY CERTIFIED TRANSMITTER

★ = Default Configuration

### Customer Information

Customer	Model No.
P.O. No.	Line Item

### Sensor

Sensor Type	Sensor 1	No. of Leads	Sensor 2 (dual-sensor option)	No. of Leads
	<input type="checkbox"/> Pt 100 $\alpha = 0.00385$ ★	<input type="checkbox"/> 2-Wire	<input type="checkbox"/> Pt 100 $\alpha = 0.00385$	<input type="checkbox"/> 2-Wire
	<input type="checkbox"/> Pt 100 $\alpha = 0.003916$	<input type="checkbox"/> 3-Wire	<input type="checkbox"/> Pt 100 $\alpha = 0.003916$	<input type="checkbox"/> 3-Wire
	<input type="checkbox"/> Pt 200 $\alpha = 0.00385$	<input type="checkbox"/> 4-Wire ★	<input type="checkbox"/> Pt 200 $\alpha = 0.00385$	
	<input type="checkbox"/> Pt 500 $\alpha = 0.00385$		<input type="checkbox"/> Pt 500 $\alpha = 0.00385$	
	<input type="checkbox"/> Pt 1000 $\alpha = 0.00385$		<input type="checkbox"/> Pt 1000 $\alpha = 0.00385$	
	<input type="checkbox"/> Cu 10		<input type="checkbox"/> Cu 10	
	<input type="checkbox"/> Ni 120		<input type="checkbox"/> Ni 120	
	<input type="checkbox"/> Transmitter Sensor Matching (C2 Option)		<input type="checkbox"/> Transmitter Sensor Matching (C2 Option)	
	<input type="checkbox"/> Nonstandard (C7 Option), Attach Calibration Schedule		<input type="checkbox"/> Nonstandard (C7 Option), Attach Calibration Schedule	
	<input type="checkbox"/> Ohms		<input type="checkbox"/> Ohms	
	<input type="checkbox"/> NIST Type B T/C	<input type="checkbox"/> NIST Type S T/C	<input type="checkbox"/> NIST Type B T/C	<input type="checkbox"/> NIST Type S T/C
	<input type="checkbox"/> NIST Type E T/C	<input type="checkbox"/> NIST Type T T/C	<input type="checkbox"/> NIST Type E T/C	<input type="checkbox"/> NIST Type T T/C
	<input type="checkbox"/> NIST Type J T/C	<input type="checkbox"/> mV	<input type="checkbox"/> NIST Type J T/C	<input type="checkbox"/> mV
	<input type="checkbox"/> NIST Type K T/C	<input type="checkbox"/> DIN Type L T/C	<input type="checkbox"/> NIST Type K T/C	<input type="checkbox"/> DIN Type L T/C
	<input type="checkbox"/> NIST Type N T/C	<input type="checkbox"/> DIN Type U T/C	<input type="checkbox"/> NIST Type N T/C	<input type="checkbox"/> DIN Type U T/C
	<input type="checkbox"/> NIST Type R T/C	<input type="checkbox"/> Type W5Re/W26Re T/C	<input type="checkbox"/> NIST Type R T/C	<input type="checkbox"/> Type W5Re/W26Re T/C

Note: A nonstandard sensor type can only be used for Sensor 1 or Sensor 2, not both.

4 mA Value	<input type="checkbox"/> 0 °C ★	<input type="checkbox"/> _____ °C	<input type="checkbox"/> _____ °F	<input type="checkbox"/> _____ °R	<input type="checkbox"/> _____ °mV	<input type="checkbox"/> _____ °K	<input type="checkbox"/> _____ Ohms
20 mA Value	<input type="checkbox"/> 100 °C ★	<input type="checkbox"/> _____ °C	<input type="checkbox"/> _____ °F	<input type="checkbox"/> _____ °R	<input type="checkbox"/> _____ °mV	<input type="checkbox"/> _____ °K	<input type="checkbox"/> _____ Ohms
Damping	<input type="checkbox"/> 5 Seconds ★	<input type="checkbox"/> Other _____ (Value must be less than 32 seconds)					

### Tagging

Hardware Tag \_\_\_\_\_

Software Tag \_\_\_\_\_ (8 characters maximum)

### Transmitter Information

Integral Meter (if ordered)  **Alternating mA and Engineering Units** ★  mA  Alternating Sensor 1 and Sensor 2

Engineering Units  Sensor 1 Engineering Units  Differential Engineering Units

Percent  Sensor 2 Engineering Units  Average Engineering Units

Alternating Differential Temperature, Sensor 1, and Sensor 2

Descriptor (C1 Option)  \_\_\_\_\_ (16 characters maximum)

Message (C1 Option)  \_\_\_\_\_ (32 characters maximum)

Date (C1 Option)  Day \_\_\_\_ (numeric)  Month \_\_\_\_ (alphabetic)  Year \_\_\_\_ (numeric)

### Jumper Selection

Failure Mode  High ★  Low

Software Security  Off ★  On

★ = Default Configuration

**Signal Selection**

**4-20 mA with simultaneous digital signal based on HART protocol ★**

Burst Mode of HART digital process variable

Burst Mode output options:

Primary variable in engineering units

Primary variable in percentage of range

All dynamic variables in engineering units and the primary variable mA value

Multidrop communication (Not applicable for Safety Certified transmitter.)

Note: This option fixes the transmitter's analog output at 4 mA.

Choose transmitter address for each transmitter (1-15) \_\_\_\_\_

Note: Default transmitter address is 1 if multidrop communication is selected.

**Alarm and Saturation Values**

**Rosemount Standard ★**

NAMUR-compliant. Available with option code A1 or CN.

Custom (option code C1).

High Alarm Level: \_\_\_\_\_ mA (must be between 21.0 and 23.0 mA)

Low Alarm Level: \_\_\_\_\_ mA (must be between 3.5 and 3.75 mA)

High Saturation Level: \_\_\_\_\_ mA (must be between 20.5 mA and the High Alarm Value minus 0.1 mA, 20.5 to 20.9 mA for safety certified)

Low Saturation Level: \_\_\_\_\_ mA (must be between the Low Alarm Value plus 0.1 mA and 3.9 mA, minimum 3.7 mA for safety certified)

### FOUNDATION FIELDBUS TRANSMITTER

★ = Default Configuration

#### Customer Information

Customer	Model No.
P.O. No.	Line Item

#### Sensor

Sensor Type	Sensor 1	No. of Leads	Sensor 2 (dual-sensor option)	No. of Leads
	<input type="checkbox"/> Pt 100 $\alpha = 0.00385$ ★ <input type="checkbox"/> Pt 100 $\alpha = 0.003916$ <input type="checkbox"/> Pt 200 $\alpha = 0.00385$ <input type="checkbox"/> Pt 500 $\alpha = 0.00385$ <input type="checkbox"/> Pt 1000 $\alpha = 0.00385$ <input type="checkbox"/> Cu 10 <input type="checkbox"/> Ni 120 <input type="checkbox"/> Transmitter Sensor Matching (C2 Option) <input type="checkbox"/> Nonstandard (C7 Option), Attach Calibration Schedule <input type="checkbox"/> Ohms <input type="checkbox"/> NIST Type B T/C <input type="checkbox"/> NIST Type E T/C <input type="checkbox"/> NIST Type J T/C <input type="checkbox"/> NIST Type K T/C <input type="checkbox"/> NIST Type N T/C <input type="checkbox"/> NIST Type R T/C	<input type="checkbox"/> 2-Wire <input type="checkbox"/> 3-Wire <input type="checkbox"/> <b>4-Wire</b> ★	<input type="checkbox"/> Pt 100 $\alpha = 0.00385$ <input type="checkbox"/> Pt 100 $\alpha = 0.003916$ <input type="checkbox"/> Pt 200 $\alpha = 0.00385$ <input type="checkbox"/> Pt 500 $\alpha = 0.00385$ <input type="checkbox"/> Pt 1000 $\alpha = 0.00385$ <input type="checkbox"/> Cu 10 <input type="checkbox"/> Ni 120 <input type="checkbox"/> Transmitter Sensor Matching (C2 Option) <input type="checkbox"/> Nonstandard (C7 Option), Attach Calibration Schedule <input type="checkbox"/> Ohms <input type="checkbox"/> NIST Type B T/C <input type="checkbox"/> NIST Type E T/C <input type="checkbox"/> NIST Type J T/C <input type="checkbox"/> NIST Type K T/C <input type="checkbox"/> NIST Type N T/C <input type="checkbox"/> NIST Type R T/C	<input type="checkbox"/> 2-Wire <input type="checkbox"/> 3-Wire

*Note: A nonstandard sensor type can only be used for Sensor 1 or Sensor 2, not both.*

Damping	<input type="checkbox"/> <b>2 seconds</b> ★	<input type="checkbox"/> Other _____ (values must be less than 32 seconds)	
Units (for all blocks)	_____ °C ★ _____ R	_____ °F _____ mV	_____ K _____ ohm
Alarm Range (for all applicable AI blocks)	Sensor 1 _____ HIGH-HIGH _____ LOW-LOW	Sensor 2 _____ HIGH-HIGH _____ LOW-LOW	Sensors 1 and 2 _____ HIGH-HIGH _____ LOW-LOW

#### Tagging

Hardware Tag \_\_\_\_\_  
 \_\_\_\_\_  
 (2 lines x 28 character max.)

Software Tag \_\_\_\_\_  
 (32 character max.)

#### Transmitter Information

**Descriptor** \_\_\_\_\_ (16 characters maximum)  
 (C1 Option)

**Message** \_\_\_\_\_  
 (C1 Option) \_\_\_\_\_ (2 Lines x 16 characters max)

**Date** Day \_\_\_\_ (numeric) \_\_\_\_\_ Month (alphabetic) \_\_\_\_\_ Year (numeric)  
 (C1 Option)

#### Switch Selection

Write Protect  **Off** ★  On  
 (Security)



## Product Data Sheet

00813-0100-4021, Rev EA  
November 2004

# Rosemount 3144P

---

*Rosemount, the Rosemount logotype, and Hot Backup are registered trademarks of Rosemount Inc.  
PlantWeb and the PlantWeb logotype is a registered trademark of Emerson Process Management.  
HART is a registered trademark of the HART Communication Foundation.  
Eurofast and Minifast are registered trademarks of Turck Inc.  
FOUNDATION is a trademark of the Fieldbus Foundation.  
All other marks are the property of their respective owners.*

### Emerson Process Management

**Rosemount Inc.**

8200 Market Boulevard  
Chanhassen, MN 55317 USA  
T (U.S.) 1-800-999-9307  
T (International) (952) 906-8888  
F (952) 949-7001

[www.rosemount.com](http://www.rosemount.com)

**Emerson Process Management  
Temperature GmbH**

Frankenstrasse 21  
63791 Karlstein  
Germany  
T 49 (6188) 992 0  
F 49 (6188) 992 112

**Emerson Process Management Asia  
Pacific Private Limited**

1 Pandan Crescent  
Singapore 128461  
T (65) 6777 8211  
F (65) 6777 0947  
[AP.RMT-Specialist@emersonprocess.com](mailto:AP.RMT-Specialist@emersonprocess.com)



**EMERSON™**  
Process Management